

**TECHNICAL MANUAL**

**OPERATOR' S , ORGANIZATIONAL, DIRECT SUPPORT,  
AND GENERAL SUPPORT MAINTENANCE MANUAL  
(INCLUDING DEPOT MAINTENANCE REPAIR PARTS AND SPECIAL TOOLS LIST)**

**FOR**

**ANTENNA TOWER TS-1A**

This publication is not available through AG Publications Center. Requisition through Commander, US Army Electronics Materiel Readiness Activity, Vint Hill Farms Station, Warrenton, VA 22186.

---

**HEADQUARTERS, DEPARTMENT OF THE ARMY  
OCTOBER 1980**

**WARNING**

**SHOCK HAZARD**

This equipment contains dangerous voltages which can cause injury or death by severe electrical shock. Be extremely careful when making voltage measurements or other checks with the equipment connected to the power source during troubleshooting. Always disconnect the power source before making any continuity tests.

**TECHNICAL MANUAL**

**OPERATOR'S , ORGANIZATIONAL, DIRECT SUPPORT,  
AND GENERAL SUPPORT MAINTENANCE MANUAL  
(INCLUDING DEPOT MAINTENANCE REPAIR PARTS AND SPECIAL TOOLS LIST)**

**FOR  
ANTENNA TOWER TS-1A**

CURRENT AS OF 28 DECEMBER 1979

This publication is not available through AG Publications Center. Requisition through Commander, US Army Electronics Materiel Readiness Activity, Vint Hill Farms Station, Warrenton, VA 22186.

---

**HEADQUARTERS, DEPARTMENT OF THE ARMY**

**LIST OF EFFECTIVE PAGES**

Dates of issue for original and changed pages are:

Original...0 ..17 October 1980

TOTAL NUMBER OF PAGES IN THIS PUBLICATION IS 160 CONSISTING OF THE FOLLOWING:

| Page No.         | *Change No. | Page No.                | *Change No. |
|------------------|-------------|-------------------------|-------------|
| Title .....      | 0           | B-1 - B-3 .....         | 0           |
| A .....          | 0           | B-4 Blank .....         | 0           |
| i- x .....       | 0           | C-1 .....               | 0           |
| 1-1 - 1-4 .....  | 0           | C-2 Blank .....         | 0           |
| 2-1 - 2-34 ..... | 0           | D-1 - D-6 .....         | 0           |
| 3-1 - 3-2 .....  | 0           | E-1 - E-2 .....         | 0           |
| 4-1 .....        | 0           | E-3 Blank .....         | 0           |
| 4-2 Blank .....  | 0           | E-4 - E-15 .....        | 0           |
| 5-1 - 5-26 ..... | 0           | E-16 Blank .....        | 0           |
| 6-1 - 6-2 .....  | 0           | E-17 - E-23 .....       | 0           |
| 7-1 - 7-5 .....  | 0           | E-24 Blank .....        | 0           |
| 7-6 Blank .....  | 0           | E-25 - E-32 .....       | 0           |
| 8-1 .....        | 0           | E-33 Blank .....        | 0           |
| 8-2 Blank .....  | 0           | E-34 - E-44 .....       | 0           |
| 9-1 .....        | 0           | F-1 - F-2 .....         | 0           |
| 9-2 Blank .....  | 0           | Index 1 - Index 7 ..... | 0           |
| A-1 .....        | 0           | Index 8 Blank .....     | 0           |
| A-2 Blank .....  | 0           |                         |             |

**\*Zero in this column indicates an original page.**

USA

RECORD OF CHANGES

| Change No. | Date | Title or Brief Description | Entered By |
|------------|------|----------------------------|------------|
|            |      |                            |            |

**OPERATOR'S ORGANIZATIONAL, DIRECT SUPPORT, AND GENERAL SUPPORT MAINTENANCE MANUAL  
(INCLUDING DEPOT MAINTENANCE REPAIR PARTS AND SPECIAL TOOLS LIST)**

**FOR**

**ANTENNA TOWER TS-1A**

**Current as of 28 December 1979**

**REPORTING OF ERRORS AND RECOMMENDING IMPROVEMENTS**

You can help improve this manual. If you find any mistakes or if you know of a way to improve the procedures, please let us know. Mail your letter, DA Form 2028 (Recommended Changes to Publications and Blank Forms), or DA Form 2028-2 located in the back of this manual, direct to: Commander, US Army Electronics Materiel Readiness Activity, ATTN: SELEM-ME-E, Vint Hill Farms Station, Warrenton, Virginia 22186. A reply will be furnished to you.

|         |                                                       | Paragraph | Page |
|---------|-------------------------------------------------------|-----------|------|
| CHAPTER | 1. INTRODUCTION                                       |           |      |
| Section | I. General                                            | 1-1       | 1-1  |
|         | II. Description and Data                              | 1-7       | 1-1  |
| CHAPTER | 2. SERVICE UPON RECEIPT AND INSTALLATION              |           |      |
| Section | I. Site and Shelter Requirements                      | 2-1       | 2-1  |
|         | II. Service Upon Receipt of Materiel                  | 2-6       | 2-9  |
|         | III. Installation Instructions                        | 2-8       | 2-9  |
|         | IV. Preliminary Adjustment of Equipment               | 2-19      | 2-34 |
|         | V. Installation and Circuit Lineup                    |           | 2-34 |
| CHAPTER | 3. OPERATING INSTRUCTIONS                             |           |      |
| Section | I. Controls and Instruments                           | 3-1       | 3-1  |
|         | II. Operation Under Usual Conditions                  | 3-3       | 3-2  |
|         | III. Operation Under Unusual Conditions               | 3-4       | 3-2  |
|         | IV. Preparation for Movement                          | 3-9       | 3-2  |
| CHAPTER | 4. OPERATOR/CREW MAINTENANCE INSTRUCTIONS             |           | 4-1  |
| CHAPTER | 5. ORGANIZATIONAL MAINTENANCE INSTRUCTIONS            |           |      |
| Section | I. Tools and Equipment                                | 5-1       | 5-1  |
|         | II. Repainting and Refinishing Instructions           | 5-2       | 5-1  |
|         | III. Lubrication Instructions                         | 5-4       | 5-2  |
|         | IV. Preventive Maintenance Checks and Services (PMCS) | 5-6       | 5-8  |
|         | V. Troubleshooting                                    | 5-8       | 5-11 |
|         | VI. Maintenance of Antenna Tower TS-1A                | 5-9       | 5-12 |
| CHAPTER | 6. FUNCTIONING OF EQUIPMENT                           |           | 6-1  |
| CHAPTER | 7. DIRECT SUPPORT MAINTENANCE INSTRUCTIONS            |           |      |
| Section | I. General                                            | 7-1       | 7-1  |
|         | II. Tools and Equipment                               | 7-2       | 7-1  |
|         | III. Troubleshooting                                  | 7-4       | 7-1  |
|         | IV. Maintenance of Antenna Tower TS-1A                | 7-5       | 7-1  |
|         | V. Direct Support Testing Procedures                  | 7-10      | 7-5  |

|          | <b>Paragraph</b>                                | <b>Page</b> |
|----------|-------------------------------------------------|-------------|
| CHAPTER  | 8. GENERAL SUPPORT MAINTENANCE INSTRUCTIONS     | 8-1         |
| CHAPTER  | 9. MATERIEL USED IN CONJUNCTION WITH MAJOR ITEM | 9-1         |
| APPENDIX | A. REFERENCES                                   | A-1         |
| APPENDIX | B. COMPONENTS OF END ITEM LIST                  | B-1         |
| Section  | I. Introduction                                 | B-1         |
|          | II. Integral Components of End Item             | B-2         |
|          | III. Basic Issue Items                          | B-3         |
| APPENDIX | C. ADDITIONAL AUTHORIZATION LIST                | C-1         |
| APPENDIX | D. MAINTENANCE ALLOCATION CHART                 | D-1         |
| Section  | I. Introduction                                 | D-1         |
|          | II. Maintenance Allocation Chart                | D-3         |
|          | III. Tool and Test Equipment Requirements       | D-5         |
|          | IV. Remarks                                     | D-6         |
| APPENDIX | E. REPAIR PARTS AND SPECIAL TOOLS LIST          | E-1         |
| Section  | I. Introduction                                 | E-1         |
|          | II. Repair Parts List                           | E-7         |
| Group    | 00 Antenna Tower TS-1A                          | E-7         |
|          | 01 Tower Section Kit No. 1                      | E-9         |
|          | 02 Tower Section Kit No. 2                      | E-11        |
|          | 03 Tower Section Kit No. 3                      | E-13        |
|          | 04 Tower Section Kit No. 4                      | E-31        |
|          | 05 Tower Adapter Installation                   | E-21        |
|          | 06 Tower Erection Kit                           | E-27        |
|          | 0601 Tower Hoist                                | E-29        |
|          | 07 Antenna Elevator and Carriage Installation   | E-31        |
|          | 0701 Antenna Carriage Assembly                  | E-35        |
|          | 0702 Elevator Assembly                          | E-37        |
|          | 0703 Elevator Hoist                             | E-39        |
| Section  | III. Special Tools List                         | E-40        |
|          | IV. National Stock Number and Part Number Index | E-41        |
| APPENDIX | F. EXPENDABLE SUPPLIES AND MATERIALS LIST       | F-1         |
| Section  | I. Introduction                                 | F-1         |
|          | II. Expendable Supplies and Materials List      | F-2         |
| INDEX    |                                                 | Index 1     |

LIST OF ILLUSTRATIONS

| Figure | Title                                                                  | Page |
|--------|------------------------------------------------------------------------|------|
| 1-1    | Antenna Tower TS-1A .....                                              | 1-2  |
| 1-2    | Tower Erection Kit .....                                               | 1-3  |
| 2-1    | Pier Layout (Sheet 1 of 2) .....                                       | 2-2  |
| 2-1    | Pier Layout (Sheet 2 of 2) .....                                       | 2-3  |
| 2-2    | Pier Construction (Sheet 1 of 4) .....                                 | 2-4  |
| 2-2    | Pier Construction (Sheet 2 of 4) .....                                 | 2-5  |
| 2-2    | Pier Construction (Sheet 3 of 4) .....                                 | 2-6  |
| 2-2    | Pier Construction (Sheet 4 of 4) .....                                 | 2-7  |
| 2-3    | Pier Loads .....                                                       | 2-8  |
| 2-4    | Tower Section No. 1 Installation (Sheet 1 of 2) .....                  | 2-12 |
| 2-4    | Tower Section No. 1 Installation (Sheet 2 of 2) .....                  | 2-13 |
| 2-5    | Tower Hoist Installation .....                                         | 2-14 |
| 2-6    | Gin Pole Installation .....                                            | 2-16 |
| 2-7    | Typical Tower Joint .....                                              | 2-17 |
| 2-8    | Brace Attachment and Multiple-Leg Sling Assembly Connection .....      | 2-18 |
| 2-9    | Elevator Track Attachment .....                                        | 2-19 |
| 2-10   | Tower Adapter Base .....                                               | 2-21 |
| 2-11   | Tower Adapter with Horizontal Tracks and Scaffold Winch Assembly ..... | 2-22 |
| 2-12   | Tower Grating Assemblies - Attachment .....                            | 2-24 |
| 2-13   | Raising Tower .....                                                    | 2-25 |
| 2-14   | Tower Grounding Kit .....                                              | 2-26 |
| 2-15   | Elevator Hoist .....                                                   | 2-27 |
| 2-16   | Top of Elevator Tracks and Tackle Block Assembly .....                 | 2-28 |
| 2-17   | Tackle Block Assembly .....                                            | 2-29 |
| 2-18   | Installation of Elevator Assembly and Antenna Carriage Assembly .....  | 2-31 |
| 3-1    | Elevator Hoist Controls .....                                          | 3-1  |
| 5-1    | Antenna Tower TS-1A Lubrication .....                                  | 5-3  |
| 5-2    | Elevator Hoist and Tower Hoist Lubrication Chart .....                 | 5-4  |
| 5-3    | Lubrication Chart for Elevator Assembly and Antenna Carriage .....     | 5-5  |
| 5-4    | Tower Adapter Lubrication Chart .....                                  | 5-6  |
| 5-5    | Rope Guide Assembly Lubrication Chart .....                            | 5-7  |
| 5-6    | Elevator and Carriage Assemblies .....                                 | 5-14 |
| 5-7    | Elevator Hoist, Cable, and Rope Guide Assembly .....                   | 5-16 |
| 5-8    | Elevator Tracks .....                                                  | 5-17 |
| 5-9    | Lowering Tower .....                                                   | 5-19 |
| 5-10   | Tower Grating Assemblies - Removal .....                               | 5-20 |
| 5-11   | Tower Section No. 4 .....                                              | 5-22 |
| 5-12   | Tower Section No. 2 or No.3 .....                                      | 5-24 |
| 5-13   | Tower Pivot and Grounding Kit .....                                    | 5-25 |
| 6-1    | Elevator Hoist Control Schematic .....                                 | 6-2  |
| 7-1    | Scaffold Winch Assembly .....                                          | 7-2  |
| 7-2    | Tower Hoist .....                                                      | 7-3  |
| 7-3    | Antenna Carriage Assembly .....                                        | 7-4  |
| 7-4    | Elevator Assembly Roller Assemblies .....                              | 7-4  |
| E-1    | Antenna Tower TS-1A (Sheet 1 of 3) .....                               | E-4  |
| E-1    | Antenna Tower TS-1A (Sheet 2 of 3) .....                               | E-5  |
| E-1    | Antenna Tower TS-1A (Sheet 3 of 3) .....                               | E-6  |
| E-2    | Tower Section Kit No. 1 .....                                          | E-8  |
| E-3    | Tower Section Kit No. 2 .....                                          | E-10 |
| E-4    | Tower Section Kit No. 3 .....                                          | E-12 |



| Figure | Title                                            | Page |
|--------|--------------------------------------------------|------|
| E-5    | Tower Section Kit No. 4 .....                    | E-14 |
| E-6    | Tower Adapter Installation (Sheet 1 of 4) .....  | E-17 |
| E-6    | Tower Adapter Installation (Sheet 2 of 4) .....  | E-18 |
| E-6    | Tower Adapter Installation (Sheet 3 of 4) .....  | E-19 |
| E-6    | Tower Adapter Installation (Sheet 4 of 4).....   | E-20 |
| E-7    | Tower Erection Kit (Sheet 1 of 2) .....          | E-25 |
| E-7    | Tower Erection Kit (Sheet 2 of 2) .....          | E-26 |
| E-8    | Tower Hoist .....                                | E-28 |
| E-9    | Antenna Elevator and Carriage Installation ..... | E-30 |
| E-10   | Antenna Carriage Assembly .....                  | E-34 |
| E-11   | Elevator Assembly .....                          | E-36 |
| E-12   | Elevator Hoist .....                             | E-38 |

**LIST OF TABLES**

| Table No. | Title                                                           | Page |
|-----------|-----------------------------------------------------------------|------|
| 1-1       | Items Comprising an Operable Antenna Tower TS-1A .....          | 1-4  |
| 2-1       | Tower Distance From Obstructions .....                          | 2-1  |
| 2-2       | Tools and Materials Required for Installation .....             | 2-9  |
| 2-3       | Recommended Torque Values for Galvanized Steel Fasteners .....  | 2-10 |
| 2-4       | Recommended Torque Values for Stainless Steel Fasteners .....   | 2-10 |
| 3-1       | Operator's Controls for Elevator Hoist .....                    | 3-1  |
| 5-1       | Organizational Maintenance Tools and Materials .....            | 5-1  |
| 5-2       | Lubricant Viscosity Groups for Electric Hoists .....            | 5-2  |
| 5-3       | Lubricants Recommended for Electric Hoists .....                | 5-2  |
| 5-4       | Organizational Preventive Maintenance Checks and Services ..... | 5-9  |
| 5-5       | Organizational Troubleshooting Chart .....                      | 5-11 |

## SAFETY SUMMARY

The following are general safety precautions that are not related to any specific procedures and therefore do not appear elsewhere in this publication. These are recommended precautions that personnel must understand and apply during many phases of operation and maintenance.

### KEEP AWAY FROM LIVE CIRCUITS

Operating personnel must at all times observe all safety regulations. Do not replace components or make adjustments inside the equipment with the voltage supply turned on. To avoid casualties, always remove power and ground a circuit before touching it.

### DO NOT SERVICE OR ADJUST ALONE

Under no circumstances should any person reach into or enter the enclosure for the purpose of servicing or adjusting the equipment except in the presence of someone who is capable of rendering aid.

### RESUSCITATION

Personnel working with or near high voltages should be familiar with modern methods of resuscitation.

The following warnings and cautions appear in the text of this manual and are repeated here for emphasis.

#### CAUTION

**Prepare a fine grain surface on top of piers. Allow minimum of 28 days for the concrete to cure before erecting tower. Otherwise piers will not adequately support tower and hoist. (Page 2-10)**

#### CAUTION

**Be sure that right and left tower pivots are not 1800 out of alignment. Otherwise pivot assemblies may be damaged when the tower section is raised. (Page 2-11)**

#### WARNING

**When working on structural tower, use safety climbing belts and pass tools and materials by using appropriate containers or ropes. (Page 2-11)**

#### WARNING

**Truck winch and hoist cables used for raising assemblies and restraining the tower during erection must have a minimum workload rating of 1 ton. The winch truck must be capable of effectively braking, lowering, and safely holding this 1-ton load. (Page 2-14)**

**WARNING**

There shall be at least two full wraps of cable on drum of tower hoist during its operation. (Page 2-15)

**CAUTION**

Before raising tower section No. 1, be sure that the tower pivots are properly aligned and not 1800 out of alignment. Otherwise pivot assemblies may be damaged when tower section No. 1 is raised. (Page 2-15)

**CAUTION**

When tower section No. 1 is almost raised and before it is set down completely, check alignment of the studs in tower support with the mating holes in tower leg that sets down. If holes and studs do not align, correct alignment to prevent damage to tower leg or tower support. (Page 2-15)

**CAUTION**

When lowering tower section No. 1, put blocks of equal height beneath the pivoting tower legs. Otherwise damage to the tower or to the piers could result when these legs rest on the piers, especially if the terrain is uneven. The supporting blocks must be the right height for allowing the attachment of tower section No. 2, and they must be capable of supporting 1000 pounds each. (Page 2-15)

**CAUTION**

Make sure that tower braces No. 6 are attached to tower leg assemblies in the prescribed manner. Otherwise the multiple-leg sling assembly may damage brace when tower is raised. (Page 2-17)

**CAUTION**

The blocks that support the top tower section (tower section No. 4) must be able to support a load of 2,000 pounds. This capacity is necessary because of the additional weight of the tower adapter which is attached before the tower is raised. (Page 2-18)

**WARNING**

The tower must be guyed or otherwise secured against high winds. (Pages 2-18, 2-20)

**CAUTION**

When installing scaffold winch assembly, make sure that crank axis is parallel to tower face A. The winch will then be able to move the antenna carriage when it rides on the horizontal tracks on the tower adapter. (Page 2-20)

**CAUTION**

Before tower is completely erect, check alignment of studs in tower support with mating holes in tower leg that comes down. If holes and studs do not align, correct the alignment. Otherwise damage to tower leg or tower support will result. (Page 2-23)

**WARNING**

Never use elevator erection sling to raise structural member when sling is supporting member by frictional contact only. Sling must go through hole or be safely secured over welded track tabs when lifting track or brace. Elevator hoist operator must stand inside tower while operating hoist, to avoid being under members being raised. (Page 2-29)

**CAUTION**

Before beginning to raise or lower loads, always operate controls momentarily to eliminate all slack in cable. Otherwise starting can cause shock load, which can cause damage to hoist or rigging. (Page 2-29)

**WARNING**

Persons must never try to ride elevator. It does not have safety features required for carrying persons. (Page 2-32)

**CAUTION**

Before raising or lowering load with elevator hoist, always operate controls momentarily to eliminate all slack in cable. This way shock load and resulting damages to hoist or rigging are avoided. (Page 2-32)

**WARNING**

Do not let elevator assembly go beyond its upper limit of travel. Take extreme care when it approaches this position. Otherwise excessive cable stress could result, and this stress could cause equipment failure or injury to persons. (Pages 2-32, 5-13)

**WARNING**

Because of weight differences between loaded and unloaded elevator assembly, shear pins may bind in locked position. If this binding occurs, do not attempt to force shear pins. Instead, operate hoist to allow their removal. (Page 2-32)

**CAUTION**

When antenna is assembled, be sure that side without protruding elements will face tower after antenna is attached to carriage. (Page 2-33)

**WARNING**

Test elevator and carriage for proper operation and for alignment before beginning to attach antenna. Be sure that crank axis of tower adapter winch is parallel to tower face A. Then the winch can move the antenna carriage as it rides on tower adapter tracks. (Page 2-33)

**WARNING**

The bottom rollers of the elevator assembly must always be at least 6 inches from the bottom ends of lowest track section. (Page 2-33)

**CAUTION**

Before raising or lowering load with elevator hoist, always operate controls momentarily to eliminate all slack in cable. Otherwise shock loading may result which can cause damage to hoist or rigging. (Page 2-33)

**WARNING**

High voltage is used in operation of electric hoists. Death or injury may result from contact with high voltage connections. The 230/460-volt power for hoist motors and controls is lethal. Disconnect this power before servicing hoist motors or controls, or any hoist circuits. (Pages 2-34, 5-11,7-1)

**CAUTION**

Always push buttons momentarily to eliminate all slack in the line before trying to hoist load. Otherwise starting can cause shock loading, which can cause damage to hoist and rigging. (Page 3-1)

**CAUTION**

Before raising or lowering load with elevator hoist, always operate controls momentarily to eliminate all slack in cable. Otherwise starting can cause shock load which could cause damage to hoist or to rigging. (Page 5-13)

**CAUTION**

When antenna is lowered, be sure that side of antenna that faces tower does not have protruding elements that would interfere with elevator motion. (Page 5-13)

**WARNING**

When elevator is lowered, bottom roller assemblies of elevator assembly must be at least 6 inches from bottom of lowest track section. (Page 5-13)

**WARNING**

Never use elevator erection sling to raise structural member when sling is supporting member by frictional contact only. Sling must go through hole or be safely secured over welded track tabs when lifting track or brace. Elevator hoist operator must stand inside tower while operating hoist, to avoid being under members being lowered. (Page 5-15)

**WARNING**

When working on structural tower, use safety climbing belts and hold tools and materials in proper containers. Pass tools and materials by using appropriate containers or ropes. (Pages 5-15, 5-23)

**WARNING**

Truck winch and hoist cables must have minimum workload rating of 1 ton. Winch truck must be able to effectively brake, lower, and safely hold this 1-ton load. (Page 5-18)

**WARNING**

The fumes of trichloroethane are toxic. Provide thorough ventilation whenever used. **DO NOT USE NEAR AN OPEN FLAME.** Trichloroethane is not flammable, but exposure of the fumes to an open flame or hot metal forms highly toxic phosgene gas. (Page 5-26)

**CAUTION**

**When assembling scaffold winch assembly, make sure that crank axis is parallel to tower face A. The winch will then be able to move antenna carriage when it rides on horizontal tracks on tower adapter. (Page 7-4)**

x

## CHAPTER 1

### INTRODUCTION

#### Section I. GENERAL

**1-1 SCOPE.** This manual provides operator/crew, organizational, direct support, and general support instructions for the installation and maintenance of the Antenna Tower TS-1A (figure 1-1). A repair parts and special tools list is also included.

**1-2 MAINTENANCE FORMS AND RECORDS.** Department of the Army forms and procedures used for equipment maintenance will be those prescribed by TM 38-750, The Army Maintenance Management System (TAMMS).

**1-3 DESTRUCTION OF ARMY MATERIEL TO PREVENT ENEMY USE.** The TS-1A shall be destroyed to prevent enemy use in accordance with instructions provided in TM 750-244-2, Procedures for Destruction of Electronics Materiel to Prevent Enemy Use (Electronics Command).

**1-4 ADMINISTRATIVE STORAGE.** Administrative storage shall be in accordance with instructions provided in TM 740-90-1, Administrative Storage of Equipment.

**1-5 CALIBRATION.** No calibration of the equipment in this group is required.

**1-6 REPORTING EQUIPMENT IMPROVEMENT RECOMMENDATIONS (EIR's).** If the TS-1A needs improvement, let us know. Send us an EIR. You, the user, are the only one who can tell us what you don't like about your equipment. Let us know why you don't like the design. Tell us why a procedure is hard to perform. Put it on an SF 368 (Quality Deficiency Report). Mail it to us at US Army Electronics Materiel Readiness Activity, ATTN: SELEMME-F, Vint Hill Farms Station, Warrenton, Virginia 22186. We'll send you a reply.

#### Section II. DESCRIPTION AND DATA

**1-7 PURPOSE AND USE.** The Antenna Tower TS-1A is used to support either the AN/GSA-131(V)1 or the AN/GSA-131(V)2 antenna group. The tower is equipped with an electrically powered elevator that carries the antenna to or from the top of the tower during antenna installation or removal.

**1-8 DESCRIPTION.** The tower (figure 1-1) is a self-supporting heavy-duty structure made of galvanized steel. It is easily erected or disassembled at the site. The structure is built to withstand the adverse effects of severe weather and/or extreme climatic conditions. The major components are described below.

*a. Tower Section Kit.* The tower section kits consist of leg assemblies (tower sections Nos. 1 through 4) made of round tubular members and square diagonal braces. All members are galvanized to assure corrosion resistance. The braces minimize tower deflections caused by high winds or by unbalanced elevator loads.

*b. Tower Adapter.* The tower adapter supports the antenna on top of the tower. Horizontal tracks properly position the antenna carriage assembly when it is rolled onto the tower adapter. The carriage is secured to the

tower adapter after positioning. Tower grating assemblies allow mounting on the tower adapter.

*c. Antenna Elevator and Carriage Kit.* The antenna elevator and carriage kit consists of vertical tracks and track supports, the antenna carriage assembly, the elevator assembly, and the elevator hoist.

(1) *Vertical Tracks and Track Supports.* Two vertical tracks are mounted to one face of the tower (referred to as face A) by means of the track supports.

(2) *Antenna Carriage Assembly.* The antenna is secured to the antenna carriage assembly, which then rolls onto the horizontal tracks of the antenna elevator assembly for transport to the tower top. At the tower top, the carriage rolls onto the horizontal tracks of the tower adapter. The rollers of the carriage are designed to withstand torques produced by unbalanced antenna loads (see paragraph 1-9). The carriage can support the antenna in severe weather or in extreme climatic environments.

(3) *Elevator Assembly.* The elevator assembly has rollers that engage the vertical elevator tracks. The elevator assembly can then be rolled up or down tower face A. Horizontal tracks are provided for the carriage.



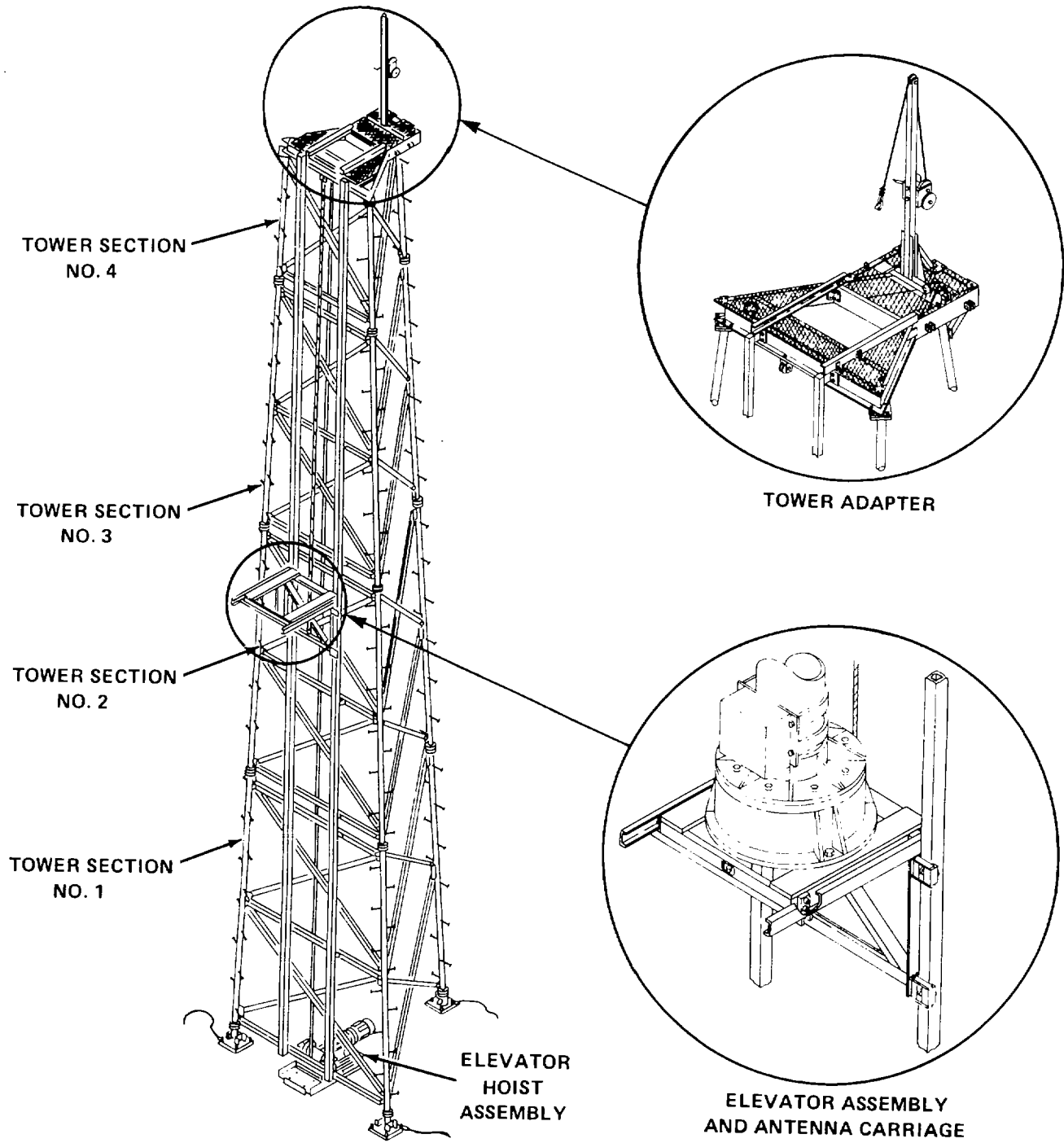

Figure 1-1. Antenna Tower TS-1A

(4) *Elevator Hoist Assembly.* The main component of the elevator hoist assembly is an electric, chain-driven hoist with worm-gear reduction. The electric hoist raises or lowers the elevator assembly. A wire cable passes through a pulley on the tower adapter and connects the elevator assembly to the electric hoist.

d. *Tower Erection Kit.* See figure 1-2. The items in the tower erection kit, together with a winch truck and common hand tools, are used to raise and lower the assembled tower. No other additional heavy equipment, such as a crane, is needed for this purpose. The kit consists of a gin pole, a snatch block, an erection cable, a multiple-leg sling assembly, and a tower hoist.

(1) *Gin Pole.* The gin pole, which is assembled from two sections, serves as a lever for raising or lowering the assembled tower. As the tower is raised or lowered, the erection cable rides in the cable slot at the top of the gin pole top section.

(2) *Snatch Block.* The snatch block, with tower hoist cable looped through it, provides the pulley power needed to raise or lower the tower.

(3) *Erection Cable.* The erection cable connects the snatch block and the multiple-leg sling assembly and serves to pivot and hoist the tower when raised and to restrain the tower when lowered. The cable is a galvanized aircraft type.

(4) *Multiple-Leg Sling Assembly.* The multiple-leg sling assembly is a 23-foot assembly with two legs. It is attached to Tower Sections Nos. 2 and 3 to elevate the tower.

(5) *Tower Hoist.* The tower hoist provides the power for raising the tower and the restraining force needed for lowering the tower. It is an electric, chain-driven hoist with worm-gear reduction.

e. *Obstruction Light.* An obstruction light is mounted near the tower top to alert aircraft of a potential hazard.

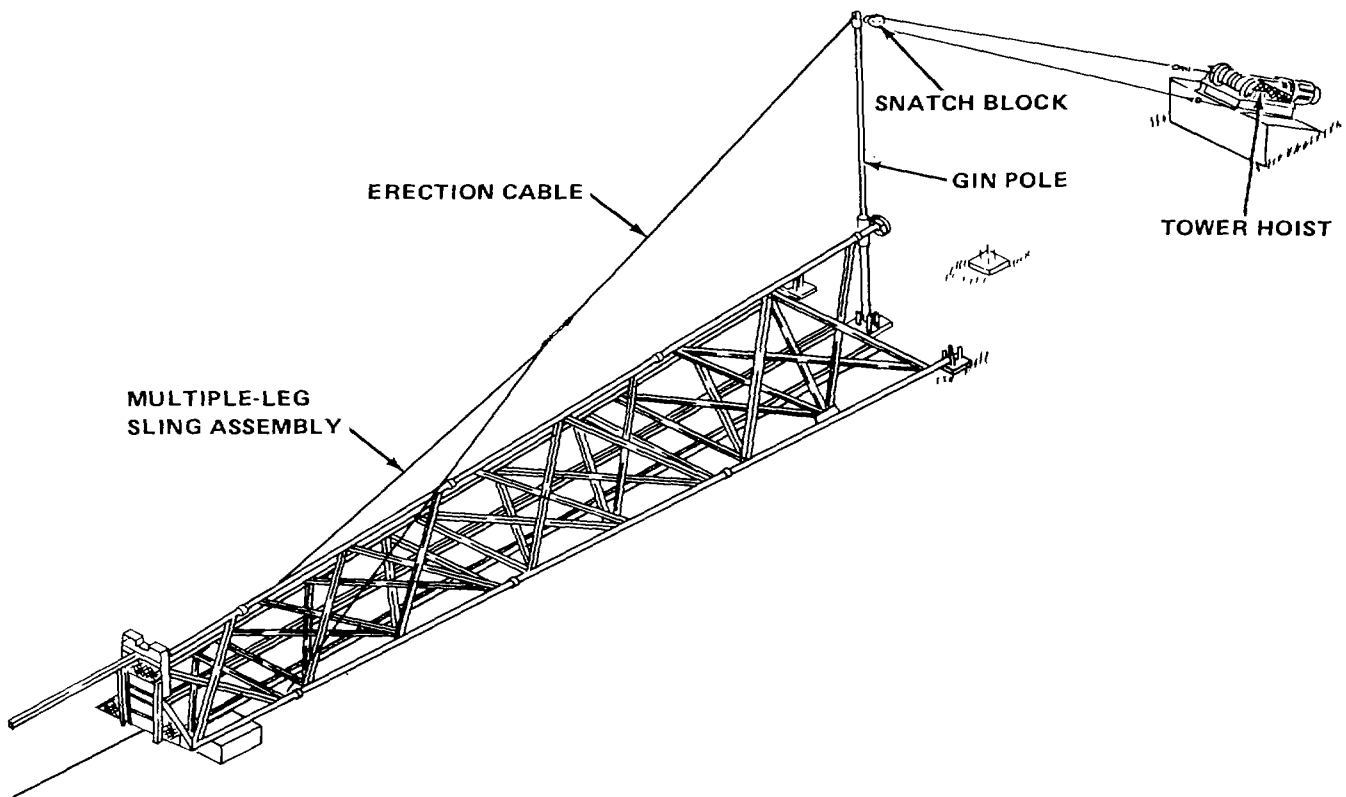

Figure 1-2. Tower Erection Kit

**1-9. TABULATED DATA.** Overall dimensions, weight, and performance characteristics of the Antenna Tower TS-1A are tabulated below.

|                                               |                      |
|-----------------------------------------------|----------------------|
| Weight .....                                  | 9,460 lbs (4,291 kg) |
| Dimensions:                                   |                      |
| Base (distance between leg centerlines) ..... | 15.0 ft (4.572m)     |
| Height (from pier) .....                      | 71.96 ft (21.933 m)  |
| Height (tower and antenna) .....              | 99.35 ft (30.282 m)  |
| Temperature range (operational) .....         | -200 to 1400 F       |
| .....                                         | (-28.9° to 600 C)    |
| Temperature range (storage) .....             | -400 to 1400 F       |
| .....                                         | (-400 to 600 C)      |
| Humidity (storage) .....                      | 60%                  |
| Windloading (tower only):                     |                      |
| 1 inch radial ice .....                       | 120mph(193 km/h)     |
| 2 inches radial ice .....                     | 60 mph (97 km/h)     |
| 3 inches radial ice .....                     | 20 mph (32 km/h)     |

Load capacities:

|                                                |                       |
|------------------------------------------------|-----------------------|
| Carriage.....                                  | 2,000 lbs (900 kg)    |
| Elevator assembly .....                        | 2,000 lbs (900 kg)    |
| Elevator hoist assembly .....                  | 2,000 lbs (900 kg)    |
| Tower hoist .....                              | 6,000 lbs (2,722 kg)  |
| Power requirements (for electric hoists) ..... |                       |
| .....                                          | 230/460 V, 3-phase,   |
| .....                                          | 60 Hz                 |
| Speed, line tower hoist .....                  | 20 ft/min (6.1 m/min) |
| Speed, power-ascent, elevator ....             | 20 ft/min (6.1 m/min) |
| Torque resistance by carriage                  |                       |
| (from unbalanced loads) .....                  | 1,000 ft-lbs (1356    |
| .....                                          | Newton-meters)        |

**1-10. ITEMS COMPRISING AN OPERABLE EQUIPMENT.** Table 1-1 lists the major components of the tower.

**Table 1-1. Items Comprising an Operable Antenna Tower TS-1A**

| NSN              | Item                                             | Quantity | Height (ft) | Depth (ft) | Width (ft)    | Weight (lb) |
|------------------|--------------------------------------------------|----------|-------------|------------|---------------|-------------|
| 5985-00-168-9392 | Tower Section Kit consisting of:                 |          |             |            |               |             |
|                  | Section No. 1                                    | 1        |             |            |               |             |
|                  | Section No. 2                                    | 1        |             |            |               |             |
|                  | Section No. 3                                    | 1        |             |            |               |             |
|                  | Section No. 4                                    | 1        |             |            |               |             |
|                  | Tower Adapter                                    | 1        |             |            |               |             |
|                  | Tower Erection Kit consisting of:                | 1        |             |            |               |             |
|                  | Tower Hoist                                      | 1        |             |            |               |             |
|                  | Gin Pole                                         | 1        |             |            |               |             |
|                  | Erection Cable                                   | 1        |             |            | 150 feet long |             |
| 5985-00-168-9394 | Multiple-leg Sling Assembly                      | 1        |             |            | 23 feet long  |             |
|                  | Snatch Block                                     | 1        |             |            |               |             |
|                  | Antenna Elevator and Carriage Kit consisting of: | 1        |             |            |               |             |
|                  | Carriage Assembly                                | 1        |             |            |               | 245         |
|                  | Elevator Assembly                                | 1        |             |            |               | 285         |
|                  | Elevator Hoist Assembly                          | 1        |             |            |               |             |
|                  | Obstruction Light                                | 1        |             |            |               |             |

CHAPTER 2

SERVICE UPON RECEIPT AND INSTALLATION

Section I. SITE AND SHELTER REQUIREMENTS

**2-1 SITING.** Whenever possible, select a tower site that meets the following requirements:

a. The area should be substantially flat for at least 150 yards in all directions from the center of the site, with not more than gentle sloping at several times that distance.

b. The site should be located on the highest level area available in the general vicinity. (A site in a sharply defined valley is usually unsatisfactory.)

c. Mountainous or hilly terrain should be avoided.

d. Proximity to large bodies of water should be avoided. Coastal refraction errors are a problem near shorelines. (If installation must be made on or near the coast, the most level area should be selected. Accuracy is greatest when signals from the target area cross the coastline at right angles.)

e. The earth surrounding the installation should have uniformly high electrical conductivity and a uniform moisture content. Areas evenly covered with grass or vegetation usually meet this requirement. (Rocky or sandy soil has low conductivity and should be avoided where possible. However, an area with uniform low conductivity is preferable to an area of high conductivity that is spotted with rocks or sand, or has varying moisture content.)

f. Regions showing scattered bare spaces of earth should be avoided. Such spaces usually indicate the presence of rocks, mineral outcroppings, or underground streams.

g. The site should be far enough from obstructions to assure greater accuracy of bearings. Table 2-1 lists recommended distances that should be maintained between the set and various obstructions.

**2-2 OTHER REQUIREMENTS.** In addition to the requirements listed above, the site area should:

a. Be level so that operators can use equipment with maximum efficiency.

b. Have good drainage. (Site should not be located in depressions or gullies.)

c. Be located away from dry streambeds. (Sudden storms can cause flash flooding.)

d. Be surveyed before erection of the tower for tower and pier layouts and for hoist location. Refer to figures 2-1, 2-2, and 2-3.

**Table 2-1. Tower Distance From Obstructions**

| Obstruction                                                                          | Distance to be maintained |
|--------------------------------------------------------------------------------------|---------------------------|
| Scattered trees and single, small buildings                                          | 200 yards                 |
| Wire fences                                                                          | 300 yards                 |
| High cliffs and deep ravines                                                         | More than 1 mile          |
| Buried metallic conductors (cables and pipelines)                                    | 300 yards                 |
| Chimney stacks and water towers                                                      | 500 yards                 |
| Overhead conductors (power lines, telephone lines, and antennas) and railroad tracks | 500 yards                 |
| Rivers, streams, and lakes                                                           | 600 yards                 |
| Forests and metal structures                                                         | 500 to 1,000 yards        |
| Mountains                                                                            | 5 to 25 miles             |

**2-3 MECHANICAL CONSIDERATIONS.** To erect and install the tower, an area approximately 135 feet (41 meters) long by 20 feet (6 meters) wide is required. The area should be able to withstand at least 3,000 pounds per square foot (14,648 kilograms per square meter). Firm clay or compact sand have these properties. (Refer to figure 2-3.) If the area selected for installation does not have this minimum load-bearing capacity, the size of all concrete piers must be increased to further distribute the load. Consult civil engineers for advice.

**2-4 POWER REQUIREMENTS.** Three-phase, 230/460 V, 60 Hz electric power must be available for the hoists.

**2-5 SHELTER REQUIREMENTS.** There are no shelter requirements for the Antenna Tower TS-1A.

NOTE: METRIC EQUIVALENT IN BOX

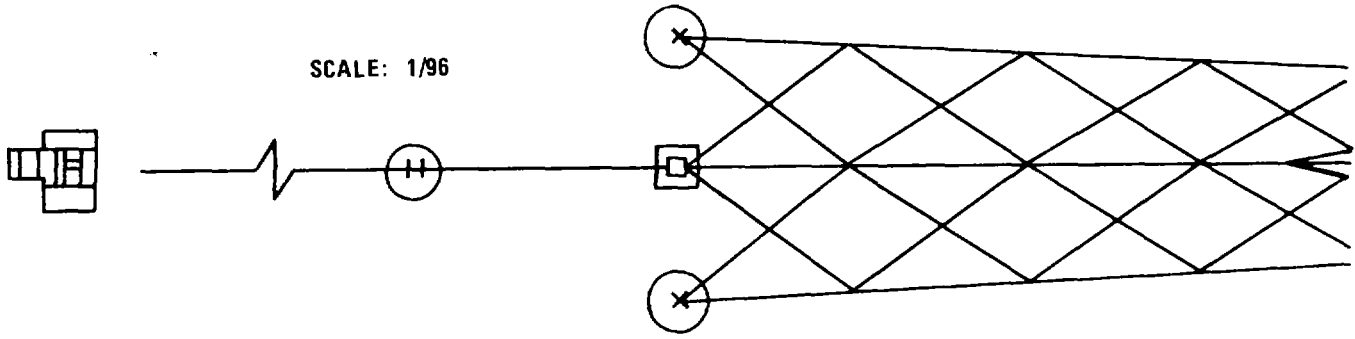

A. TOP VIEW

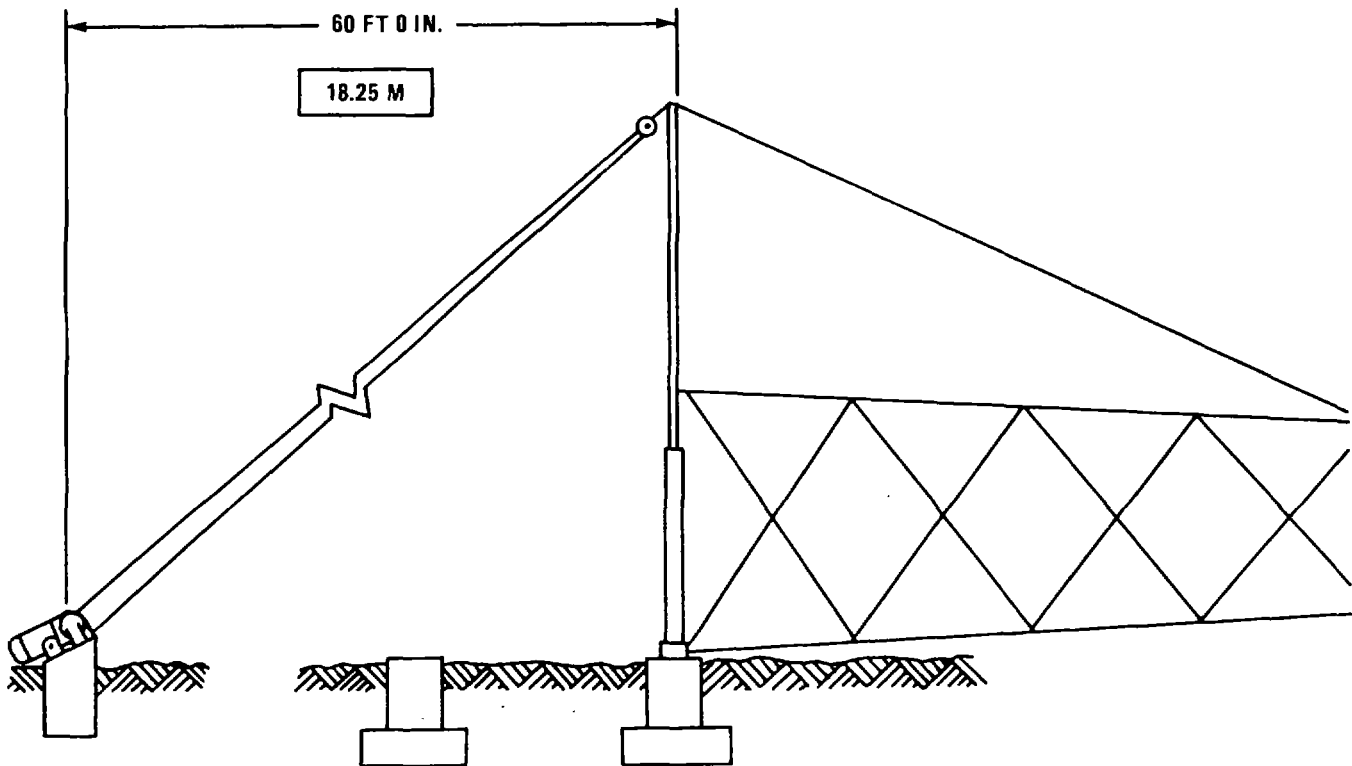

B. SIDE VIEW

Figure 2-1. Pier Layout (Sheet 1 of 2)

NOTE: METRIC EQUIVALENTS IN BOXES

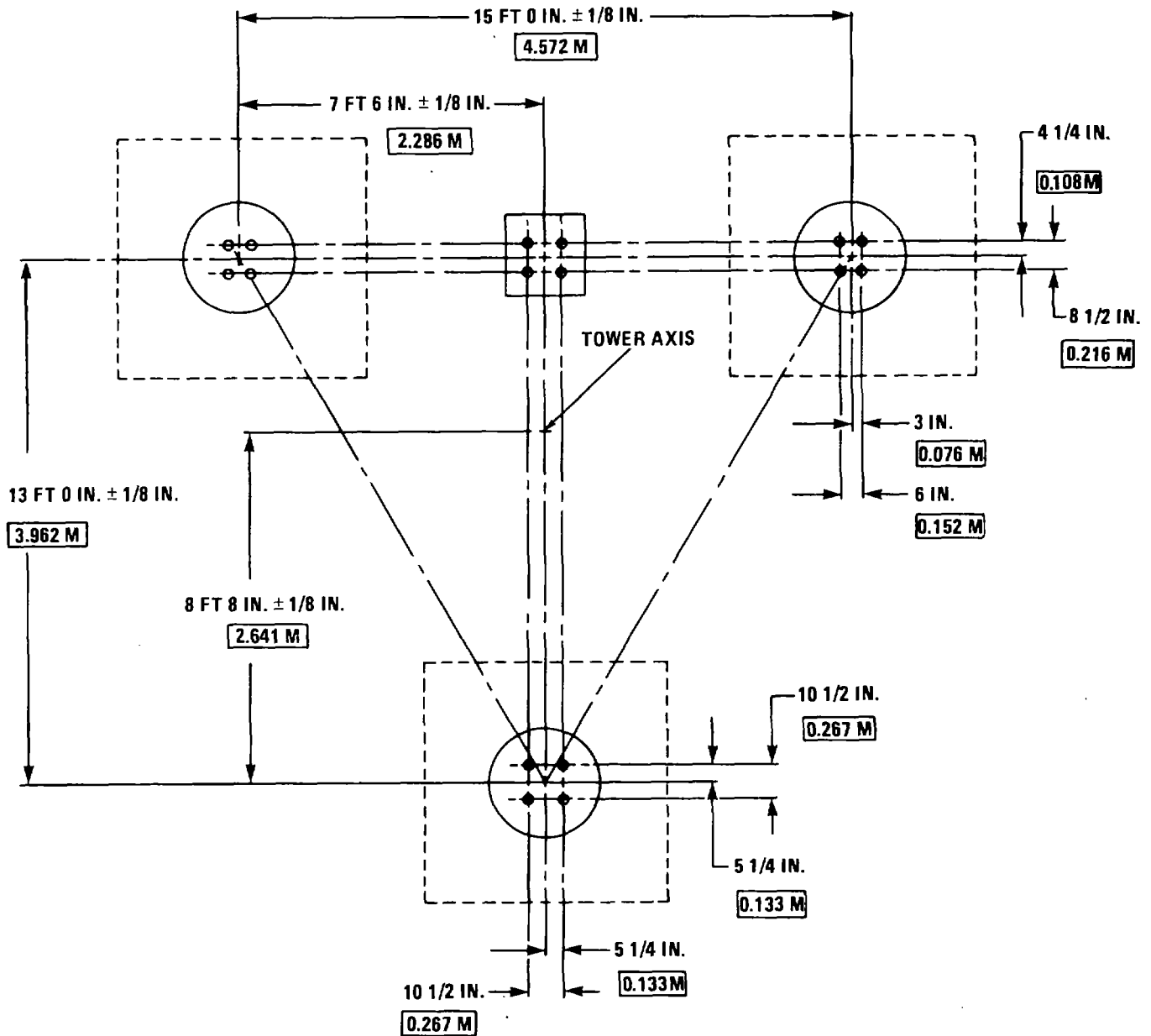

TOP VIEW  
DESIGN OPTION NO. 1

Figure 2-1. Pier Layout (Sheet 2 of 2)

NOTE: METRIC EQUIVALENTS IN BOXES

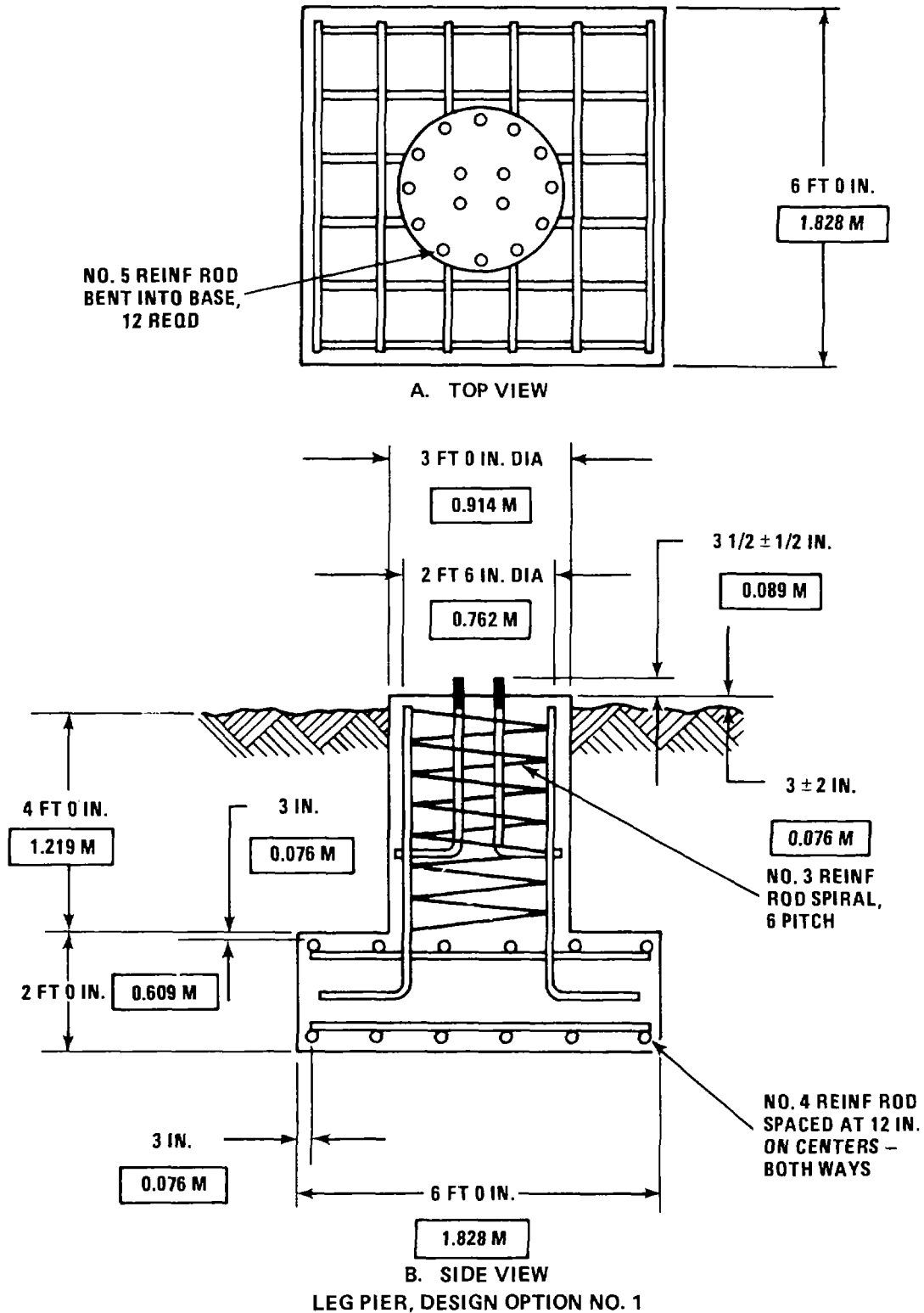
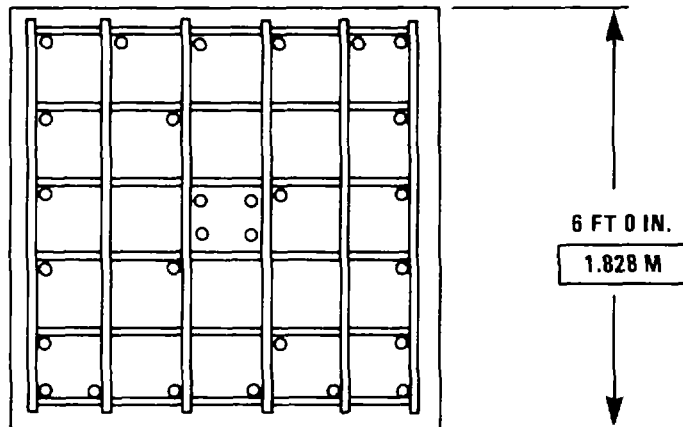
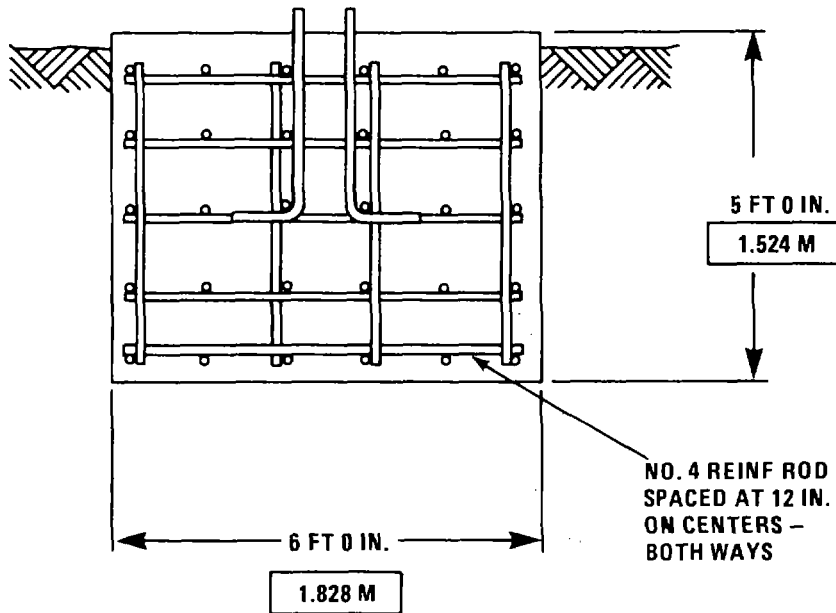

Figure 2-2. Pier Construction (Sheet 1 of 4)

NOTE: METRIC EQUIVALENTS IN BOXES



A. TOP VIEW



B. BOTTOM VIEW

LEG PIER, DESIGN OPTION NO. 2

Figure 2-2. Pier Construction (Sheet 2 of 4)



NOTE: METRIC EQUIVALENTS IN BOXES

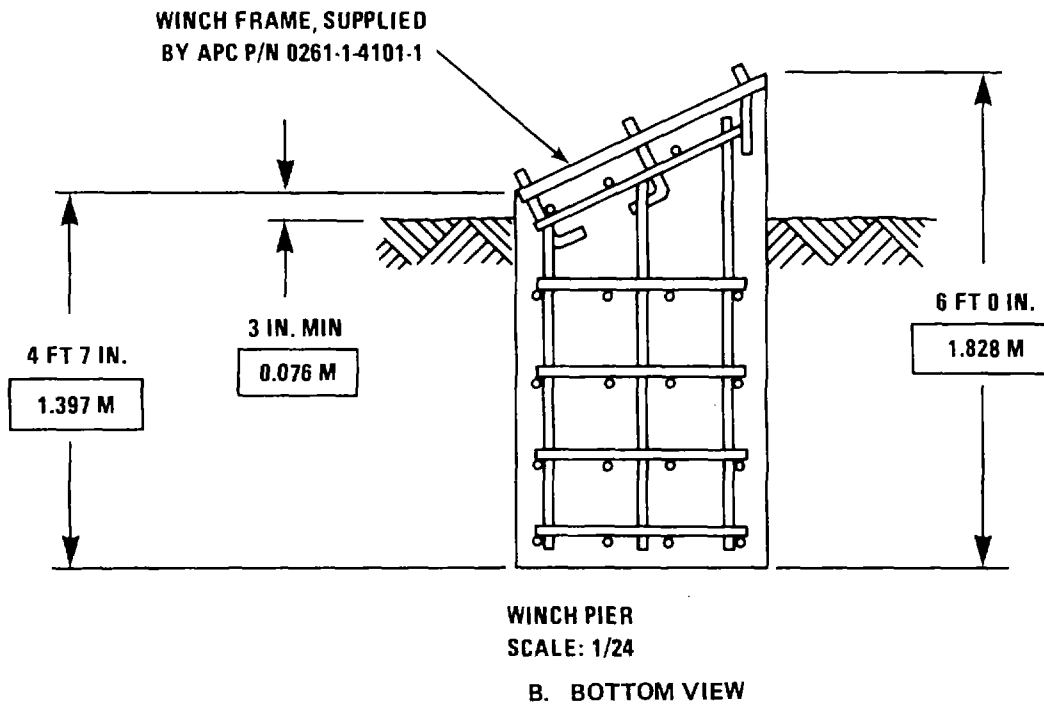
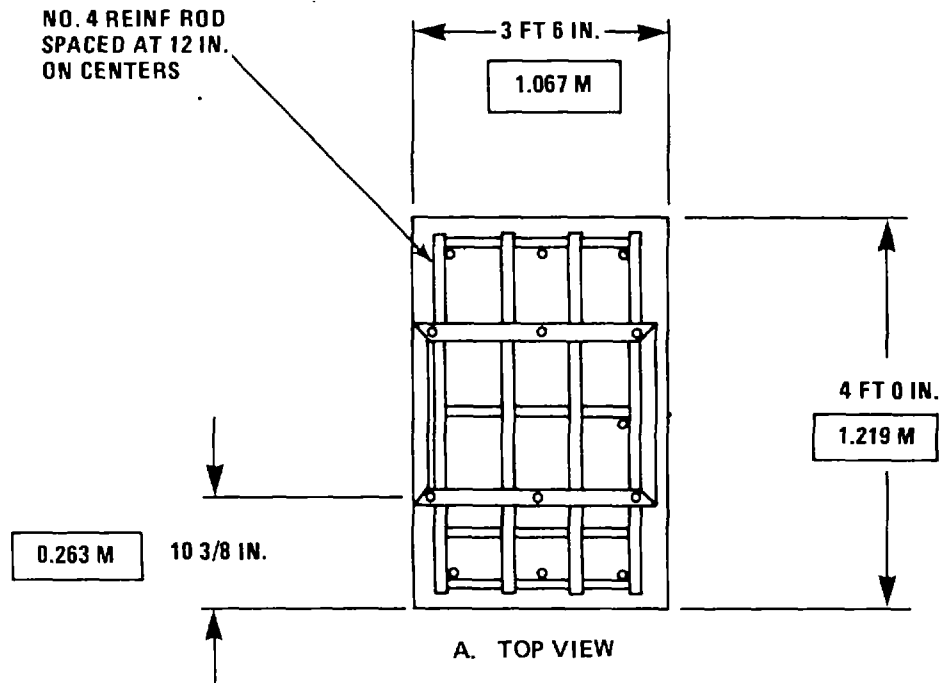
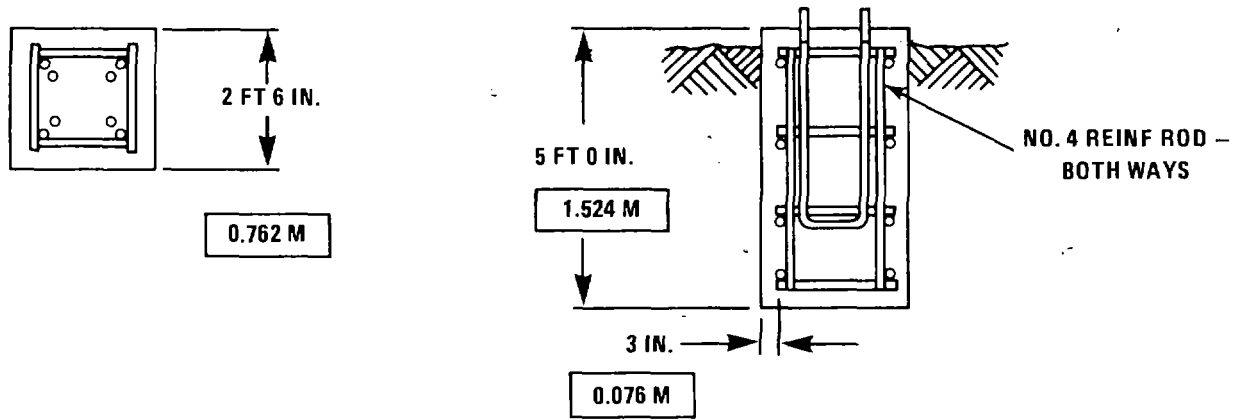
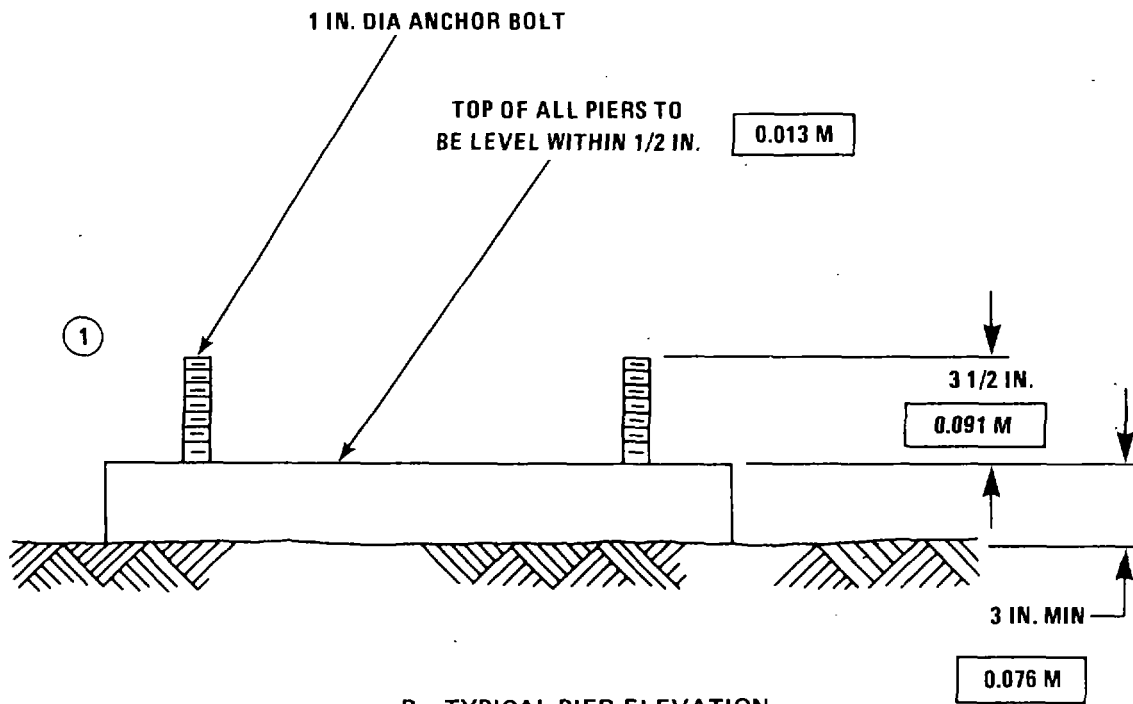

Figure 2-2. Pier Construction (Sheet 3 of 4)

NOTE: METRIC EQUIVALENTS IN BOXES



A. GIN POLE PIER



B. TYPICAL PIER ELEVATION

Figure 2-2. Pier Construction (Sheet 4 of 4)

NOTE: METRIC EQUIVALENTS IN BOXES

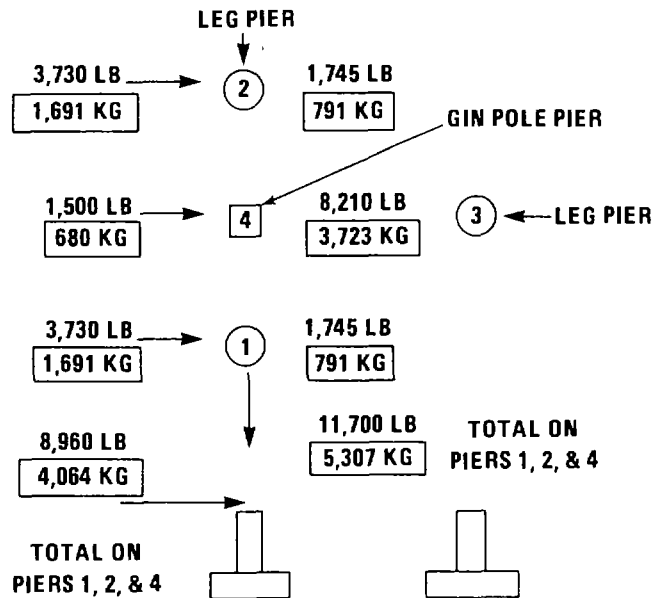

A. FOUNDATION LOADS WHILE RAISING TOWER

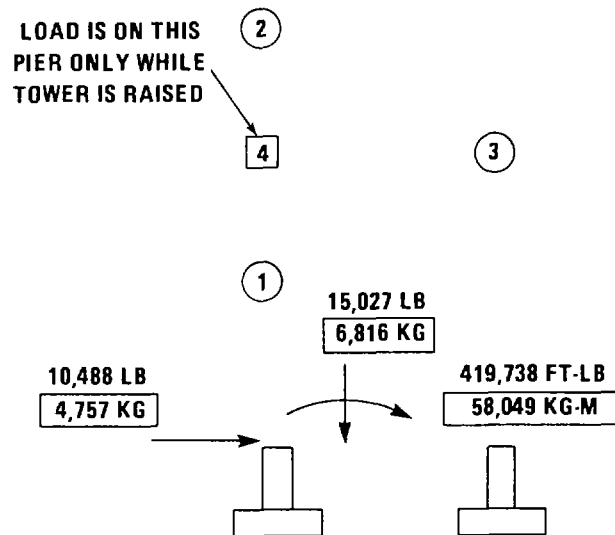

B. FOUNDATION LOADS DUE TO MAXIMUM DESIGN LOADS ON ANTENNA STRUCTURE

Figure 2-3. Pier Loads

**Section II. SERVICE UPON RECEIPT OF MATERIEL**

**2-6 UNPACKING.** The Antenna Tower TS-1A is shipped to the installation site completely disassembled and crated. Equipment and materials should be unloaded carefully and stored systematically to prevent damage and to allow rapid identification of related parts.

**2-7 CHECKING UNPACKED EQUIPMENT.**

a. Inspect the equipment for damage incurred during shipment. If the equipment has been damaged, report the damage on SF Form 364, Report of Discrepancy (ROD).

b. Check the equipment against the component listing in this manual and the packing slip to see if the shipment is complete. Report all discrepancies in accordance with instructions set forth in TM 38-750. The equipment should be placed in service even though a minor assembly or part that does not affect proper functioning is missing.

c. Check to see whether the equipment has been modified. (Equipment which has been modified will have the Modification Work Order (MWO) number on the equipment.) Check also to see whether all currently applicable MWO's have been applied.

**Section III. INSTALLATION INSTRUCTIONS**

**2-8 TOOLS, TEST EQUIPMENT, AND MATERIALS REQUIRED FOR INSTALLATION.** Table 2-2 lists the tools and materials needed for assembling and erecting

the Antenna Tower TS-1A. No test equipment or special tools are required.

**Table 2-2. Tools and Materials Required for Installation**

| Item                              | Purpose                                                | Applicable publication |
|-----------------------------------|--------------------------------------------------------|------------------------|
| Clamps, open wire                 | Secures winch cable.                                   |                        |
| Helmet, safety, (1 per person)    | Protects personnel.                                    |                        |
| Ladder, 20-foot                   | Used while erecting tower.                             |                        |
| Level, spirit, 48-inch            | Levels parts of tower structure.                       |                        |
| Level, spirit, 78-inch            | Levels parts of tower structure.                       |                        |
| Level, transit                    | Levels erection site and concrete piers.               |                        |
| Strap, safety, industrial*        | Protects personnel while erecting tower faces.         |                        |
| Tape, measuring, general purpose* | Measures lengths of parts.                             |                        |
| Tripod                            | Supports transit level.                                |                        |
| Truck, winch, 1-ton capacity      | Raises and restrains tower assemblies during erection. |                        |

\*Part of Antenna Installation Tool Kit TK-202/G. Item is authorized for use.

**Table 2-2. Tools and Materials Required for Installation - Continued**

| Item                         | Purpose                            | Applicable publication |
|------------------------------|------------------------------------|------------------------|
| Wrench, torque, 0-200 ft-lbs | Tightens fasteners.                |                        |
| Wrench, torque, 0-600 ft-lbs | Tightens fasteners.                |                        |
| Concrete                     | Used for tower and erection piers. |                        |
| Reinforcing steel            | Reinforces concrete piers.         |                        |

**2-9 PRELIMINARY PROCEDURES.**

**CAUTION**

**Prepare a fine grain surface on top of piers. Allow minimum of 28 days for the concrete to cure before erecting tower. Otherwise piers will not adequately support tower and hoist.**

a. The tower piers must be prepared by personnel experienced in making steel-reinforced structures, and with advice of civil engineers. The size of the piers and the amount of reinforcing steel needed must be determined from consideration of soil conditions and vertical loads. Dig the pier holes and set the top of the forms with a level. Wire in the reinforcing steel as required. With the aid of a template, place the pier bolts and hoist bolts in position while the concrete is still soft. Refer to figure 2-2 for template hole patterns.

b. If material is stockpiled, take care to protect it from damage. Stack material before erection to provide clear working spaces and to enable rapid identification of components.

c. To insure uniformity, all screw and bolt threads on attaching hardware should face in the same direction wherever possible (all outward, all inward, all up, or all down), unless otherwise specified. For proper tightening of hardware, use calibrated torque wrenches, and tighten to the torques recommended for the fasteners. See tables 2-3 and 2-4 for torque values. Should socket wrenches be used instead of torque wrenches, tighten bolts by fully compressing the lockwasher and turning the nut an additional one-half turn.

**Table 2-3. Recommended Torque Values for Galvanized Steel Fasteners**

| Diameter (inches) | Torque values (ft-lbs) |          |
|-------------------|------------------------|----------|
|                   | Hi-strength            | Standard |
| 1/4               | 9                      | 6        |
| 5/16              | 17                     | 11       |
| 3/8               | 30                     | 19       |
| 7/16              | 47                     | 30       |
| 1/2               | 69                     | 45       |
| 9/16              | 103                    | 66       |
| 5/8               | 145                    | 93       |
| 3/4               | 234                    | 150      |
| 7/8               | 372                    | 202      |
| 1                 | 551                    | 300      |

**Table 2-4. Recommended Torque Values for Stainless Steel Fasteners**

| Diameter (inches) | Torque values |
|-------------------|---------------|
| 1/4               | 79 in-lbs     |
| 5/16              | 138 in-lbs    |
| 3/8               | 21 ft-lbs     |
| 7/16              | 33 ft-lbs     |
| 1/2               | 45 ft-lbs     |

**2-10 SUMMARY OF TOWER ERECTION.****NOTE**

**Erection personnel must be thoroughly familiar with installation instructions before attempting erection of tower.**

a. Tower is assembled on the ground as follows:

- (1) Tower section No. 1 is assembled.
- (2) Tower section No. 1 is attached to tower pivots and raised.
- (3) Gin pole is attached.
- (4) Tower section No. 1 is lowered.
- (5) Tower sections Nos. 2, 3, and 4 are assembled and attached.

b. If elevator tracks are available when tower is erected, they are attached while tower is on the ground.

c. Tower adapter is attached to rest of tower.

d. Tower is raised.

e. Elevator tracks are installed if they were not available before tower was raised.

f. Carriage is assembled, mounted to the tower, and antenna is erected.

**2-11 SAFETY PRECAUTIONS.** The following safety precautions shall be observed before and during installation of the Antenna Tower TS-1A:

a. Be familiar with the usual safety precautions and safety equipment that are used when handling structural steel.

b. Maintain erection tools and equipment in safe condition, especially lifting and safety gear.

c. Take special care when handling structural steel in icy or wet weather. The steel is likely to be slippery under these conditions.

d. Wear gloves and other protective clothing when handling structural steel in extreme cold. Unprotected skin can freeze onto very cold steel.

e. Secure partial assemblies against high winds at all times during erection.

f. Do not use tower hoist as a hoist for persons. Required safety devices for personnel are not provided for this hoist.

g. Truck winch and winch cable used for raising assemblies and restraining tower during erection must have minimum work load rating of 1 ton. Winch truck must be capable of effectively braking, lowering, and safely holding this 1-ton load.

h. When working on structural tower, use safety climbing belts and hold tools and materials in containers.

Pass tools and materials by using appropriate containers or ropes.

i. When hoisting equipment, the operator shall not be permitted to perform any other work. He shall not leave controls until the load has been safely attached or safely lowered to the ground.

j. Only the erection gear prescribed in this manual shall be used without consulting a civil engineer. All other erection and installation procedures must be approved by a civil engineer.

**2-12 ASSEMBLY OF TOWER.** Only the equipment listed in table 2-2 and common hand tools, such as wrenches and screwdrivers, are needed for assembling the tower. The step-by-step procedure that follows enables rapid and accurate assembly of the tower.

a. *Tower Section No. 1.* Refer to figure 2-4.

(1) Screw 126 tower step bolts (2, sheet 1) tight against all tower leg assemblies (1, sheet 1) A, B, and C. Refer to detail of tower step in figure 2-4.

(2) Attach tower support to pier A and hold in place with eight nuts (18, sheet 2) and lockwashers (19, sheet 2). Do not tighten these pier nuts (18, sheet 2) until the tower is raised later.

**CAUTION**

**Be sure that right and left tower pivots are not 1800 out of alignment. Otherwise pivot assemblies may be damaged when the tower section is raised.**

(3) Attach tower base pivot assemblies (20, sheet 2) to pier B and C and secure with 16 nuts (18, sheet 2) and lockwashers (19, sheet 2).

(4) Face A will be assembled first. Lay out tower legs B (1, sheet 1) and C (1, sheet 1) on the ground. Attach tower braces Nos. 1 (10, sheet 1) and 2 (12, sheet 1) to tower legs and secure with four bolts (3, sheet 1), nuts (4, sheet 1), and lockwashers (5, sheet 1). Secure crossover junctions of braces with two bolts (6, sheet 1), nuts (7, sheet 1), and lockwashers (8, sheet 1).

(5) Hoist up leg B (1, sheet 1), with leg C (1, sheet 1) on the ground serving as an axis, so that the second side, face B of the tower section, can be built on the ground. Repeat step (4) to assemble face B.

**WARNING**

**When working on structural tower, use safety climbing belts and pass tools and materials by using appropriate containers or ropes.**

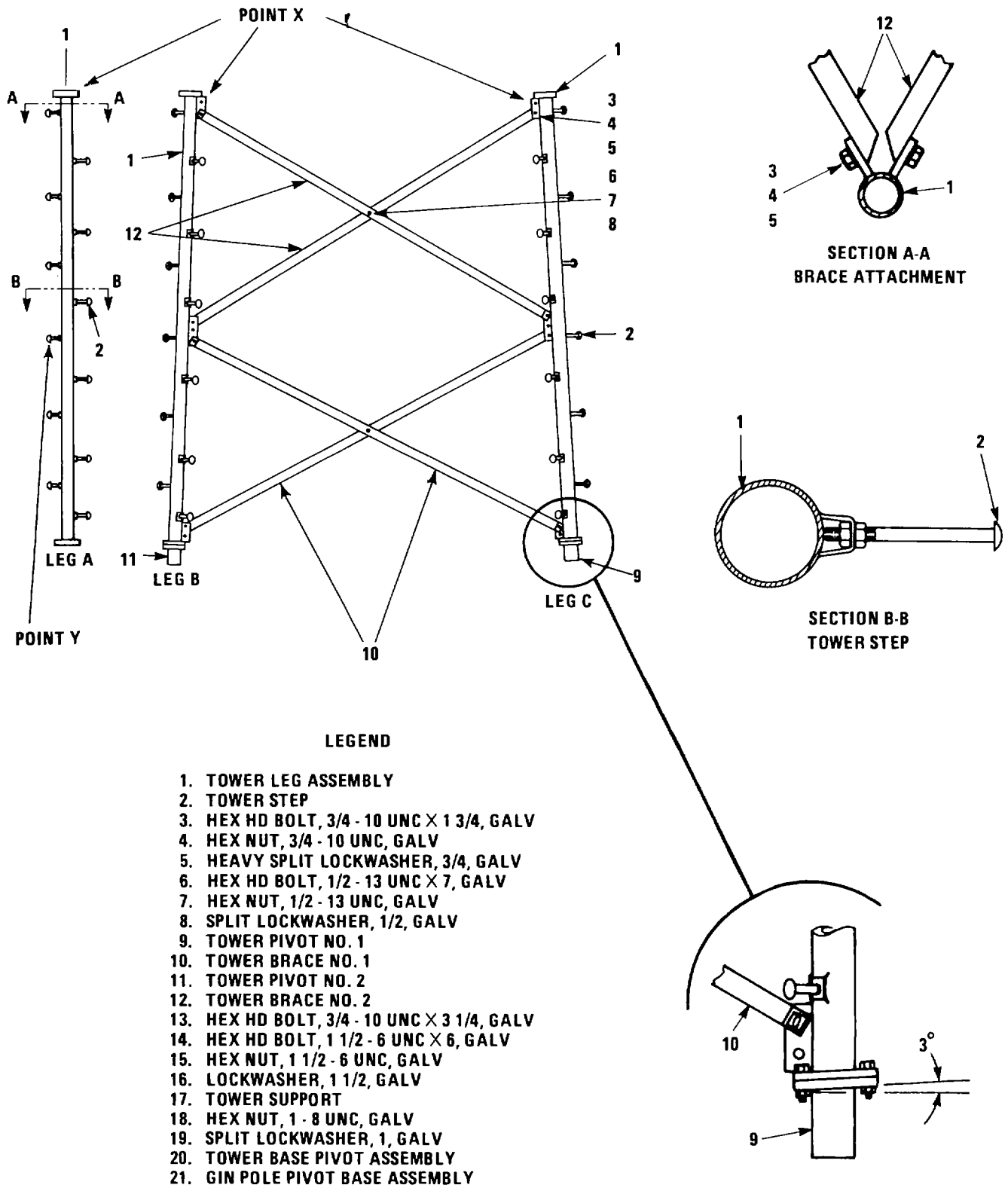

Figure 2-4. Tower Section No. 1 Installation (Sheet 1 of 2)

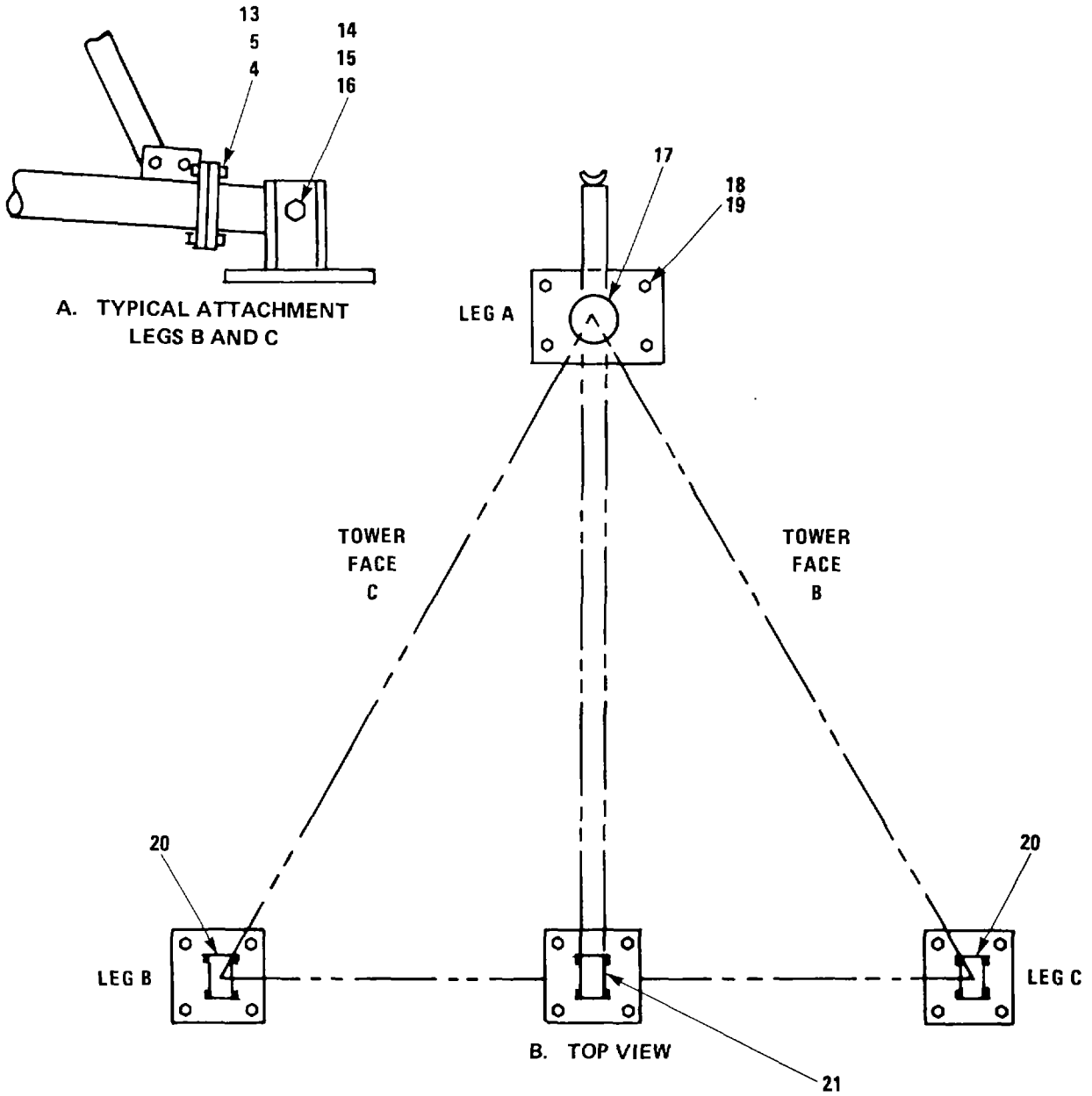

Figure 2-4. Tower Section No. 1 Installation (Sheet 2 of 2)



(6) Complete tower section No. 1 by assembling the third side, face C, by the same procedure as for face A, in step (4). Use a ladder to reach the upper bolts on tower leg B (1, sheet 1).

(7) Attach tower pivots Nos. 1 (9, sheet 1) and 2 (11, sheet 1), for legs B and C, to base pivot assemblies (20, sheet 2) of piers B and C and secure with two bolts (14, sheet 2), nuts (15, sheet 2), and lockwashers (16, sheet 2).

*b. Tower Hoist Installation.* Refer to figure 2-5.

(1) Attach eye bolt (6) to hoist frame assembly (13). Secure with two nuts (7) and one lockwasher (8).

(2) If hoist frame assembly (13) is not already on winch pad (12), attach it with winch bolts (9) mating to holes in hoist frame assembly.

(3) Place tower hoist (1) on hoist frame assembly (13), with holes mating winch bolts (9). Secure with six nuts (10) and lockwashers (11).

(4) Before using tower hoist, remove red oil-level plug and check gearcase for proper oil level. Fill with oil through one of upper openings until oil reaches oil-level hole. Replace plugs tightly after this check. Check that the rest of the tower hoist is properly lubricated. See figure 5-2.

(5) Connect power.

*c. Raising Tower Section No. 1.* Refer to figure 2-4.

**WARNING**

**Truck winch and hoist cables used for raising assemblies and restraining the tower during erection must have a minimum workload rating of 1 ton. The winch truck must be capable of effectively braking, lowering, and safely holding this 1-ton load.**

(1) Attach truck winch cable to leg A, point Y. With winch truck, elevate tower section No. 1 so that pivoting

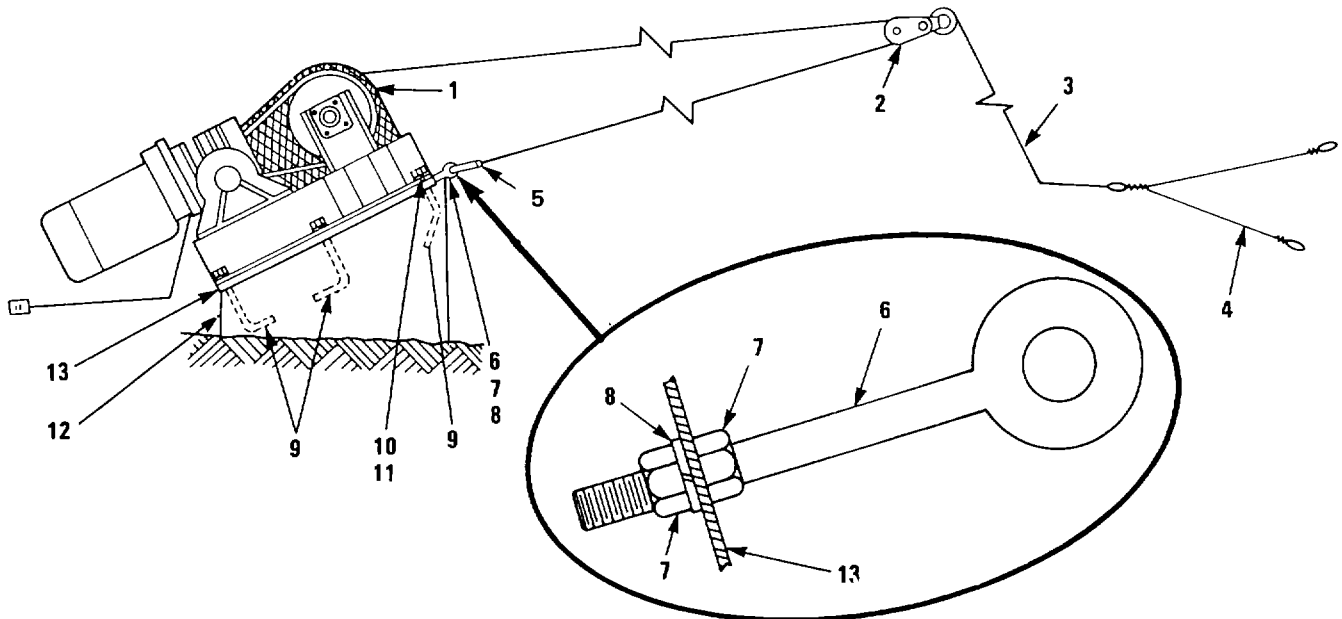

**LEGEND**

- |                                |                                 |
|--------------------------------|---------------------------------|
| 1. TOWER HOIST                 | 8. SPLIT LOCKWASHER, 1, GALV    |
| 2. SNATCH BLOCK                | 9. WINCH BOLT                   |
| 3. ERECTION CABLE              | 10. HEX NUT, 3/4 - 10 UNC, GALV |
| 4. MULTIPLE-LEG SLING ASSEMBLY | 11. SPLIT LOCKWASHER, 3/4, GALV |
| 5. ANCHOR SHACKLE, 3.2-TON     | 12. WINCH PAD                   |
| 6. EYE BOLT, 1 - 8 UNC, GALV   | 13. HOIST FRAME ASSEMBLY        |
| 7. HEX NUT, 1 - 8 UNC, GALV    |                                 |

Figure 2-5. Tower Hoist Installation

legs, legs B and C, can be attached to tower pivots (9 and 11, sheet 1), and lower tower into position. Make sure that the bottoms of legs B (1, sheet 1) and C (1, sheet 1) are adjacent to tower pivots. Attach legs B and C to tower pivots and secure with six bolts (13, sheet 2), nuts (5, sheet 2), and lockwashers (4, sheet 2).

(2) Place blocks under legs B and C approximately 2 feet from top of tower section. These blocks must be high enough to hold tower section horizontal when released. Rest tower section on these blocks.

**WARNING**

**There shall be at least two full wraps of cable on drum of tower hoist during its operation.**

(3) Remove winch line from leg A and attach this winch line to legs B and C at point X. Attach cable of tower hoist to leg A at point X.

**CAUTION**

**Before raising tower section No. 1, be sure that the tower pivots are properly aligned and not 1800 out of alignment. Otherwise pivot assemblies may be damaged when tower section No. 1 is raised.**

(4) With tower hoist, raise tower section, and with winch truck, restrain tower section as it is set down.

**CAUTION**

**When tower section No. 1 is almost raised and before it is set down completely, check alignment of the studs in tower support with the mating holes in tower leg that sets down. If holes and studs do not align, correct alignment to prevent damage to tower leg or tower support.**

(5) Before allowing tower leg A to come completely down, make sure that the holes in the flange of this leg align with the bolts in tower support. If studs and holes do not align, loosen pier nuts (18, sheet 2) on piers B and C or brace nuts (4 and 7, sheet 1), and adjust the position of the tower. If alignment still cannot be achieved, tap nuts (18, sheet 2) on pier bolts of pier A with a hammer to slightly bend the bolts and thereby move tower support into position under leg A.

(6) If gin pole is not to be installed immediately, secure tower section to piers with four nuts (18, sheet 2) and lockwashers (19, sheet 2).

*d. Gin Pole.* Refer to figure 2-6. Before installing tower section No. 2, the gin pole is attached to tower section No.

(1) while this section is still erect. Install gin pole as follows: (1) Attach gin pole pivot base assembly (13) to anchor bolts (2) on gin pole pier. Secure with four nuts (3) and lockwashers (4).

(2) Place slotted end of gin pole bottom section (7) into gin pole pivot base assembly (13) and rest the other end of this section on pier A.

(3) Insert 11-inch bolt (14) into gin pole pivot base assembly (13) and fit it through slot in gin pole bottom section (7). Secure with nut (6).

(4) Insert gin pole top section (1) through pier A tower support (8) and into gin pole bottom section (7). Align these two sections with bolt (5) that connects them. Secure with bolt (5) and nut (6).

*e. Tower Section No. 2.* Refer to figure 2-4, unless otherwise indicated.

**CAUTION**

**When lowering tower section No. 1, put blocks of equal height beneath the pivoting tower legs. Otherwise damage to the tower or to the piers could result when these legs rest on the piers, especially if the terrain is uneven. The supporting blocks must be the right height for allowing the attachment of tower section No. 2, and they must be capable of supporting 1000 pounds each.**

**NOTE**

**When tower section No. 1 is lowered, be sure that cable rides in cable slot at top of gin pole. Gin pole will then act as lever.**

(1) With winch truck, begin lowering tower section No. 1. Restrain tower section by means of tower hoist. Lower tower section down on its side. Detach winch truck and tower hoist cables from tower section.

(2) Assemble tower section No. 2 following the procedure for assembling tower section No. 1 (paragraph 2-12a, steps (4) through (6)), except attach tower braces No. 3 instead of No. 1 and tower braces No. 4 instead of No. 2.

(3) With winch truck, raise tower section No. 2 by leg A. Attach this section to tower section No. 1 and secure with nine bolts (2, figure 2-7), lockwashers (3, figure 2-7) and nuts (4, figure 2-7).

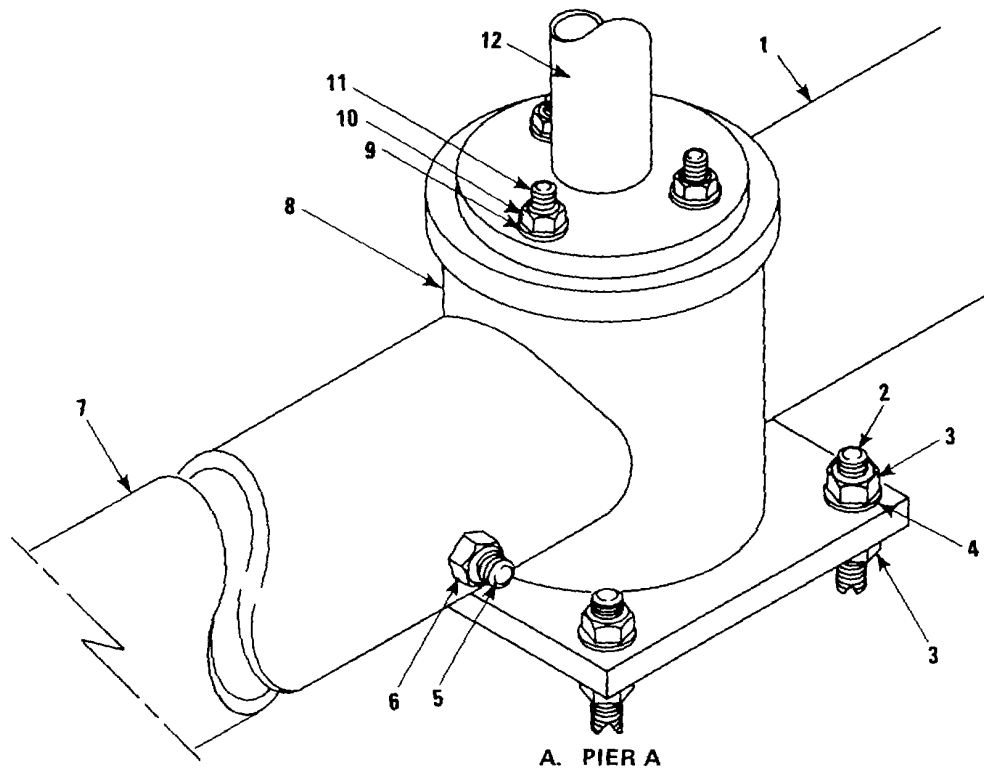

A. PIER A

**LEGEND**

- 1. GIN POLE TOP SECTION
- 2. ANCHOR BOLT
- 3. HEX NUT, 1 - 8 UNC, GALV
- 4. SPLIT LOCKWASHER, 1, GALV
- 5. HEX HD BOLT, 1 1/2 - 6 UNC X 12
- 6. HEX NUT, 1 1/2 - 6 UNC, GALV
- 7. GIN POLE BOTTOM SECTION
- 8. TOWER SUPPORT
- 9. HEAVY SPLIT LOCKWASHER, 3/4, GALV
- 10. HEX NUT, 3/4 - 10 UNC X 3 1/4, GALV
- 11. HEX HD BOLT, 3/4 - 10 UNC, GALV
- 12. LEG A
- 13. GIN POLE PIVOT BASE ASSEMBLY
- 14. HEX HD BOLT, 1 1/2 - 6 UNC X 11, GALV

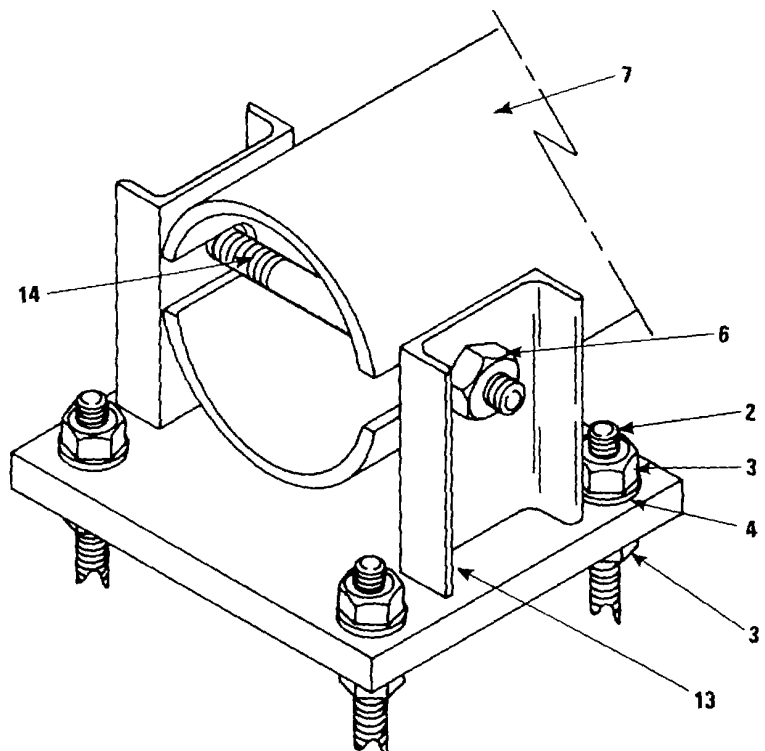

B. GIN POLE PIER

Figure 2-6. Gin Pole Installation

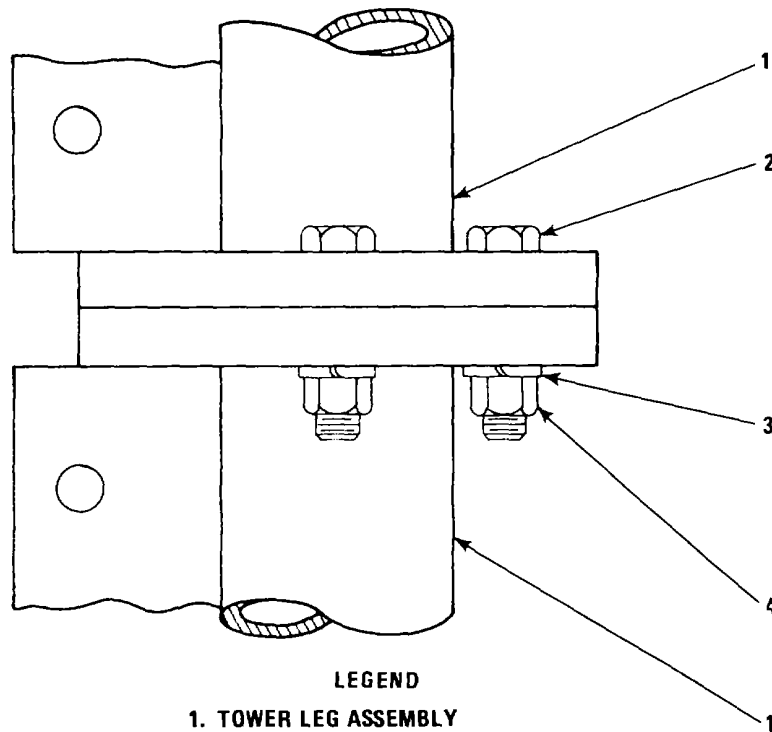

**Figure 2-7. Typical Tower Joint**

- (4) Remove blocks from under tower section No. 4.
1. Place blocks, approximately 2 feet high and capable of supporting at least 1,250 pounds each, under legs B and C, 1 foot 6 inches from the top of tower section No. 4.
  2. Lower tower onto these blocks.

*f. Tower Section No. 3.*

**CAUTION**

**Make sure that tower braces No. 6 are attached to tower leg assemblies in the prescribed manner. Otherwise the multiple-leg sling assembly may damage brace when tower is raised.**

- (1) Assemble tower section No. 3 by the same procedure as for tower section No. 1 (paragraph 2-12a, steps (4) through (6)), except attach tower braces No. 5 instead of No. 1 and tower braces No. 6 instead of No. 2.
2. Make sure that braces No. 6 are attached to leg assemblies in the manner shown in figure 2-8.

- (2) Use winch truck to raise tower section No. 3. Attach this section to tower section No. 2 and secure with nine bolts (2, figure 2-7), lockwashers (3, figure 2-7), and nuts (4, figure 2-7).

- (3) Remove blocks from under tower section No. 2 and place them 1 foot 6 inches from the top of tower section No. 3 under legs B and C. Lower tower onto these blocks.

*g. Tower Section No. 4.*

- (1) Assemble tower section No. 4. The procedure is the same as for tower sections Nos. 2 and 3 (paragraph 2-12a, steps (4) through (6)), except that instead of two sets of braces (six each) there is only one set of six braces tower braces No. 7.

- (2) Raise tower section No. 4 by means of winch truck. With nine bolts (2, figure 2-7), lockwashers (3, figure 2-7), and nuts (4, figure 2-7), attach this tower section to tower section No. 3 and secure.

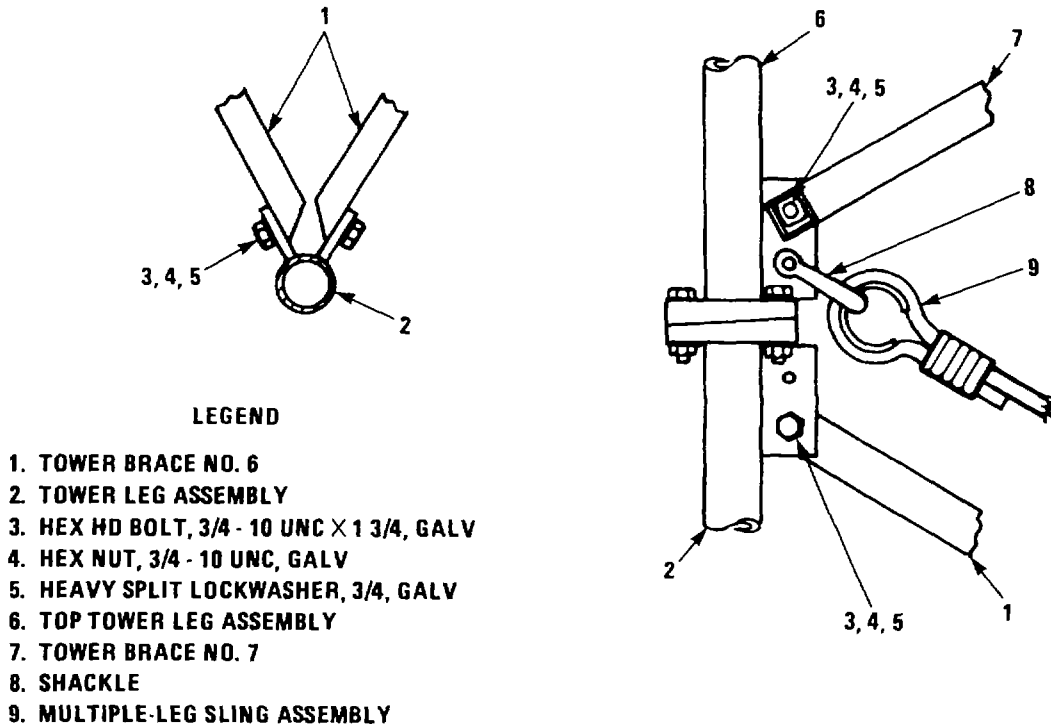

Figure 2-8. Brace Attachment and Multiple-Leg Sling Assembly Connection

**CAUTION**

The blocks that support the top tower section (tower section No. 4) must be able to support a load of 2,000 pounds. This capacity is necessary because of the additional weight of the tower adapter which is attached before the tower is raised.

- (3) Remove blocks from under tower section No. 3. Place blocks, capable of supporting 2,000 pounds each, under legs B and C and 1 foot 6 inches from top of tower. Lower tower onto these blocks.

**2-13 INSTALLATION OF VERTICAL ELEVATOR TRACKS WITH TOWER LOWERED.**

**WARNING**

The tower must be guyed or otherwise secured against high winds.

If vertical elevator tracks are available when tower sections Nos. 1 through 4 are assembled and attached, install them next by following the procedure described below. If not, install the tower adapter next (paragraph 2-14). See paragraph 2-16c for instructions for attaching vertical elevator tracks after tower is erected. With the tower resting on support blocks, all tracks and track supports are to be attached to face A of the tower (the face that lies between legs B and C). Refer to figure 2-9.

- a. Attach track supports Nos. 1 (14), 2 (13), and 3 (12) to tower section No. 1. Secure to tower leg assemblies with six bolts (7), nuts (8), and lockwashers (9).
- b. As in step a, and with the same attaching hardware, attach track supports Nos. 4 (11), 5 (10), and 6 (6) to tower section No. 2; track supports Nos. 7 (5), 8 (4), and 9 (3) to tower section No. 3; and track support No. 10 (2) to tower section No. 4.
- c. Attach six track assemblies (15) to track supports of tower sections Nos. 1,2, and 3 (two for each tower section) and secure with 36 bolts (25), nuts (17), and lockwashers (18) as shown in the detail of figure 2-9.

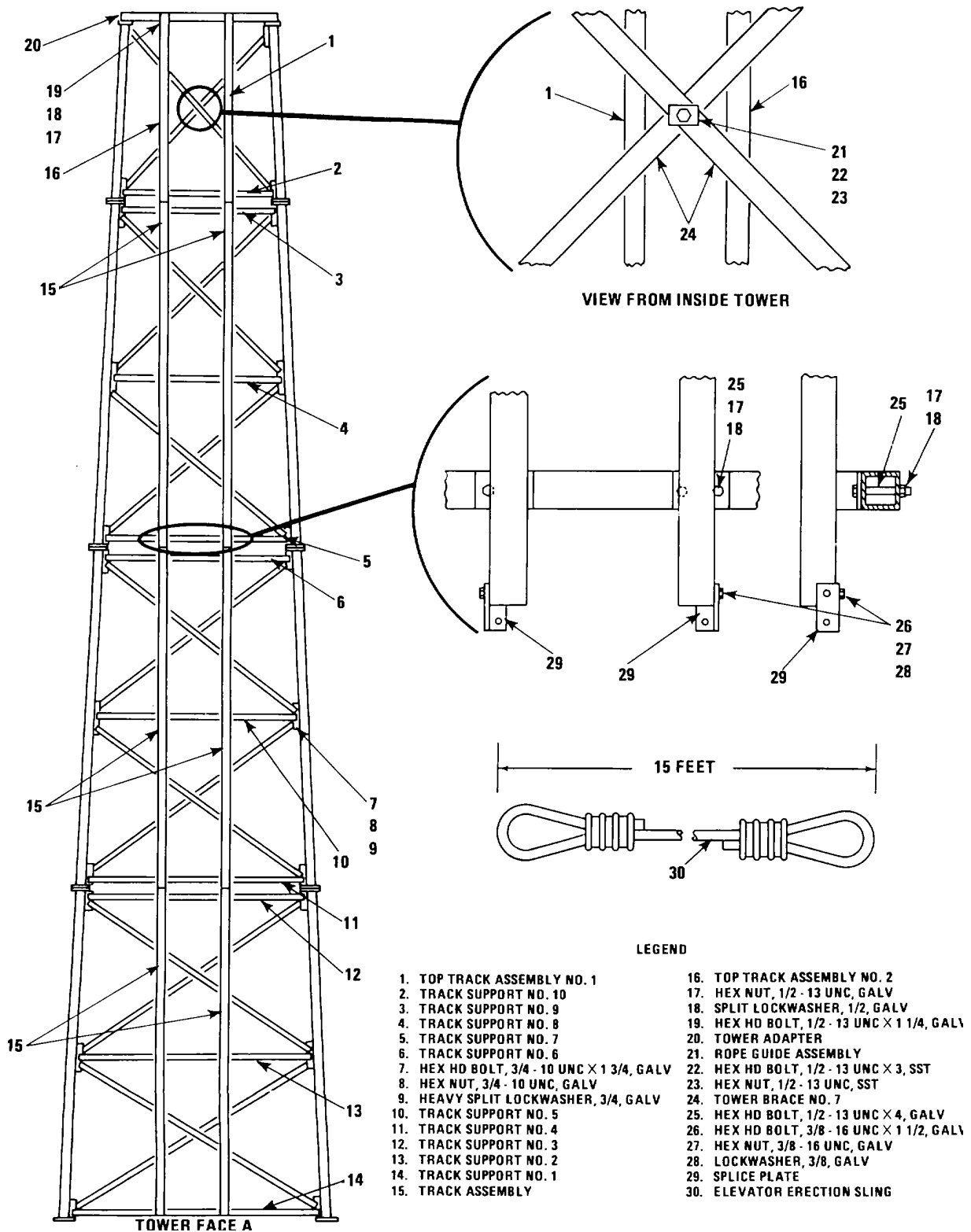

Figure 2-9. Elevator Track Attachment  
2-19

d. Attach top track assemblies Nos. 1 (1) and 2 (16) to track support No. 10 (2), on tower section No. 4, and secure with four bolts (25), nuts (17), and lockwashers (18).

e. Align track sections and make sure that none of the gaps between these sections is more than 1/16 inch.

f. Attach 6 splice plates (29) and secure with 12 bolts (26), nuts (27), and lockwashers (28).

## 2-14 ASSEMBLY AND INSTALLATION OF TOWER

**ADAPTER.** The tower adapter, including the winch and the gratings, is assembled and attached to the tower after the tower has been assembled, but before it is raised.

### WARNING

**The tower must be guyed or otherwise secured against high winds.**

### CAUTION

**When installing scaffold winch assembly, make sure that crank axis is parallel to tower face A. The winch will then be able to move the antenna carriage when it rides on the horizontal tracks on the tower adapter.**

### NOTE

**Scaffold winch assembly need only be attached if antenna is to be attached.**

a. *Base of Tower Adapter.* Refer to figure 2-10.

(1) Install channel support assemblies Nos. 1 (26), 2 (21), and 3 (30) as noted in step (2) below.

(2) Attach channel support assembly No. 1 (26) to tower legs B (28) and C (22); channel support assembly No. 2 (21) to tower legs A (18) and C (22); and channel support assembly No. 3 (30) to tower legs A (18) and B (28). Secure with six bolts (23), nuts (4), and lockwashers (5) and with six bolts (13), nuts (4), lockwashers (5), and square beveled washers (6).

(3) Attach two channel tie plates (24) to channel support assemblies Nos. 2 (21), 1 (26), and 3 (30) at leg corners B and C and secure with eight bolts (13), nuts (4), lockwashers (5), and square beveled washers (6).

(4) Attach scaffold support plate (2) to channel support assemblies Nos. 2 (21) and 3 (30) at corner A. Secure with four bolts (3), nuts (4), lockwashers (5), and square beveled washers (6), but do not tighten bolts.

(5) Attach scaffold support channels Nos. 1 (1) and 2 (7) to corner A of tower adapter.

(a) On top, fasten them to scaffold support plate (2) with two bolts (3), nuts (4), lockwashers (5), and square beveled washers (6).

(b) On bottom, attach scaffold support channels Nos. 1 (1) and 2 (7) to the plates welded on channel support assemblies Nos. 2 (21) and 3 (30) and secure with two bolts (13), nuts (4), lockwashers (5), and square beveled washers (6).

(6) Attach scaffold support braces Nos. 1 (15) and 2 (16) to scaffold support channels Nos. 1 (1) and 2 (7) and to the plate welded on tower leg A (18). Secure with four bolts (17), nuts (9), and lockwashers (10).

(7) Attach channel support angle (20) and scaffold hinge assembly No. 2 (14) at the same time to channel support assembly No. 2 (21) and secure with four bolts (8), nuts (9), and lockwashers (10). Repeat this step to attach channel support angle (20) and scaffold hinge assembly No. 1 (32) to channel support assembly No. 3 (30).

(8) Attach two channel support angles (20) to channel support assemblies Nos. 2 (21) and 3 (30) where long track brace (29) will go. Secure with eight bolts (17), nuts (9), and lockwashers (10).

(9) Attach four corner plates (12) to scaffold hinge assemblies Nos. 2 (14) and 1 (32) and scaffold support channels Nos. 1 (1) and 2 (7) at top and bottom. Secure with 16 bolts (8), nuts (9), lockwashers (10), and square beveled washers (11).

(10) Attach four scaffold reinforcing plates (19) to scaffold hinge assemblies Nos. 2 (14) and 1 (32) and channel support assemblies Nos. 2 (21) and 3 (30) at top and bottom. Secure with eight bolts (8), nuts (9), lockwashers (10), and square beveled washers (11).

(11) Attach short track brace (31) to channel support assemblies Nos. 2 (21) and 3 (30) and to channel support angles (20) as well. Fasten short track brace to channel support angles with eight bolts (17), nuts (9), and lockwashers (10).

(12) Attach two channel support angles (20) to channel support assemblies Nos. 2 (21) and 3 (30) where long track brace (29) will be attached and secure with eight bolts (17), nuts (9), and lockwashers (10).

(13) Attach long track brace (29) to channel support assemblies Nos. 2 (21) and 3 (30) and channel support angles (20).

(14) Secure long track brace (29) to channel support angles (20) by eight bolts (17), nuts (9), and lockwashers (10).

b. *Horizontal Tracks.* Refer to figure 2-11.

(1) Attach two track angles (20) to channel support assembly No. 1 (26) and two track angles (20) to long track brace (24). Secure with four bolts (11), nuts (4), lockwashers (5), and square beveled washers (19).

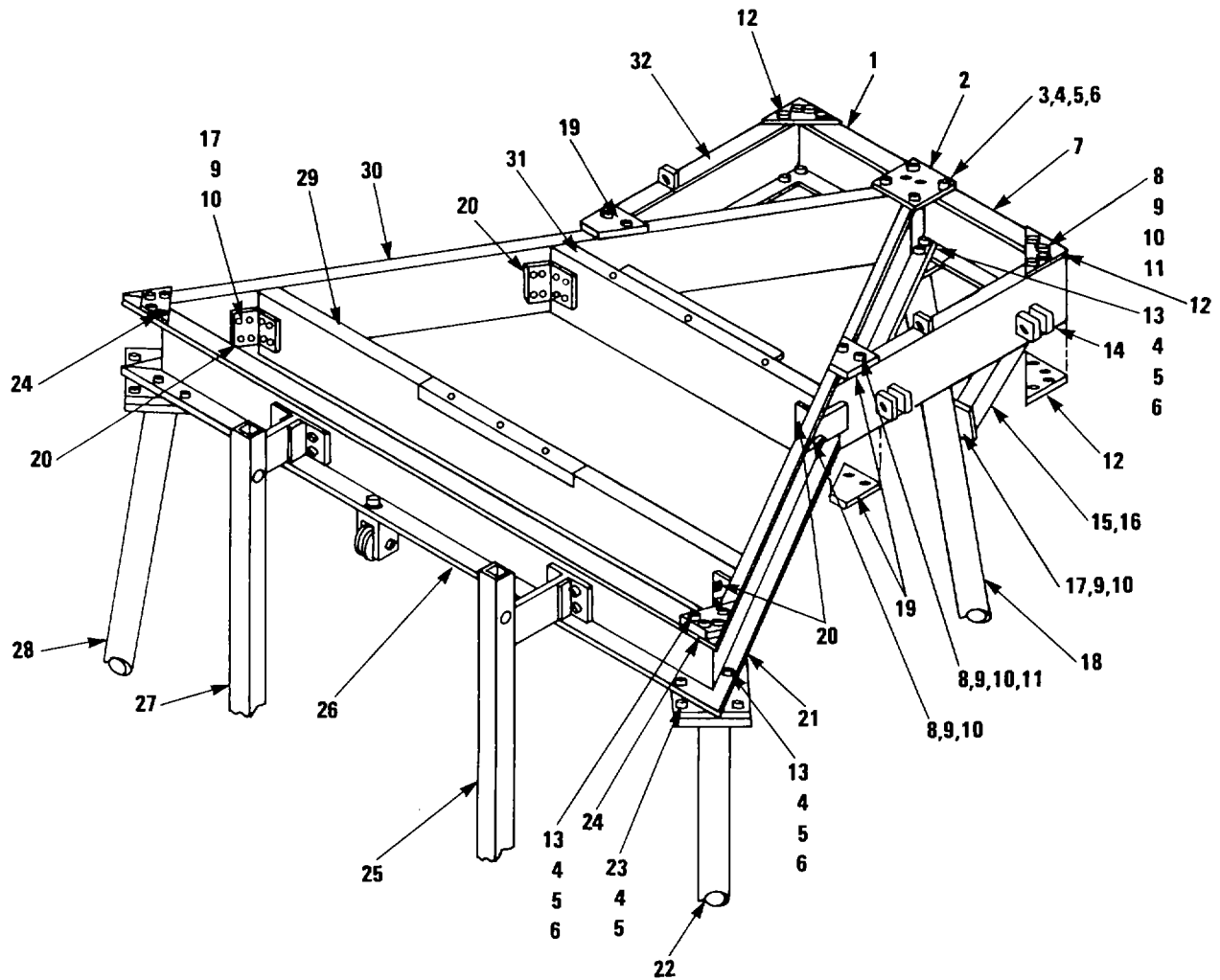

**LEGEND**

- |                                             |                                             |
|---------------------------------------------|---------------------------------------------|
| 1. SCAFFOLD SUPPORT CHANNEL NO. 1           | 17. HEX HD BOLT, 3/8 - 16 UNC X 1 1/4, GALV |
| 2. SCAFFOLD SUPPORT PLATE                   | 18. TOWER LEG A                             |
| 3. HEX HD BOLT, 1/2 - 13 UNC X 2, GALV      | 19. SCAFFOLD REINFORCING PLATE              |
| 4. HEX NUT, 1/2 - 13 UNC, GALV              | 20. CHANNEL SUPPORT ANGLE                   |
| 5. SPLIT LOCKWASHER, 1/2, GALV              | 21. CHANNEL SUPPORT ASSEMBLY NO. 2          |
| 6. SQUARE BEVELED WASHER, 1/2, GALV         | 22. TOWER LEG C                             |
| 7. SCAFFOLD SUPPORT CHANNEL NO. 2           | 23. HEX HD BOLT, 1/2 - 13 UNC X 1 3/4, GALV |
| 8. HEX HD BOLT, 3/8 - 16 UNC X 1 3/4, GALV  | 24. CHANNEL TIE PLATE                       |
| 9. HEX NUT, 3/8 - 16 UNC, GALV              | 25. TOP TRACK ASSEMBLY NO. 1                |
| 10. SPLIT LOCKWASHER, 3/8, GALV             | 26. CHANNEL SUPPORT ASSEMBLY NO. 1          |
| 11. SQUARE BEVELED WASHER, 3/8, GALV        | 27. TOP TRACK ASSEMBLY NO. 2                |
| 12. CORNER PLATE                            | 28. TOWER LEG B                             |
| 13. HEX HD BOLT, 1/2 - 13 UNC X 2 1/2, GALV | 29. LONG TRACK BRACE                        |
| 14. SCAFFOLD HINGE ASSEMBLY NO. 2           | 30. CHANNEL SUPPORT ASSEMBLY NO. 3          |
| 15. SCAFFOLD SUPPORT BRACE NO. 1            | 31. SHORT TRACK BRACE                       |
| 16. SCAFFOLD SUPPORT BRACE NO. 2            | 32. SCAFFOLD HINGE ASSEMBLY NO. 1           |

Figure 2-10. Tower Adapter Base



LEGEND

1. WINCH SUPPORT
2. WINCH CABLE
3. HEX HD BOLT, 3/8 - 16 UNC X 3 3/4, GALV
4. HEX NUT, 3/8 - 16 UNC, GALV
5. SPLIT LOCKWASHER, 3/8, GALV
6. HEX HD BOLT, 1/2 - 13 UNC X 4 1/4, GALV
7. HEX NUT, 1/2 - 13 UNC, GALV
8. SPLIT LOCKWASHER, 1/2, GALV
9. WINCH SUPPORT BRACE
10. SCAFFOLD SUPPORT PLATE
11. HEX HD BOLT, 3/8 - 16 UNC X 1 1/4, GALV
12. TACKLE BLOCK ASSEMBLY
13. HEX NUT, 5/8 - 11 UNC, GALV
14. SPLIT LOCKWASHER, 5/8, GALV
15. SQUARE BEVELED WASHER, 5/8, GALV
16. HEX HD BOLT, 5/8 - 11 UNC X 1 3/4, GALV
17. HORIZONTAL TRACK NO. 1
18. CHANNEL SUPPORT ASSEMBLY NO. 2
19. SQUARE BEVELED WASHER, 3/8, GALV
20. TRACK ANGLE
21. HEX HD BOLT, 1/2 - 13 UNC X 1 1/4, GALV
22. TOP TRACK ASSEMBLY NO. 1
23. ELEVATOR HOIST CABLE
24. LONG TRACK BRACE
25. TOP TRACK ASSEMBLY NO. 2
26. CHANNEL SUPPORT ASSEMBLY NO. 1
27. HORIZONTAL TRACK NO. 2
28. CHANNEL SUPPORT ASSEMBLY NO. 3
29. HEX HD BOLT, 3/8 - 16 X 1 1/2, GALV
30. SHORT TRACK BRACE
31. WINCH SUPPORT ASSEMBLY
32. WINCH

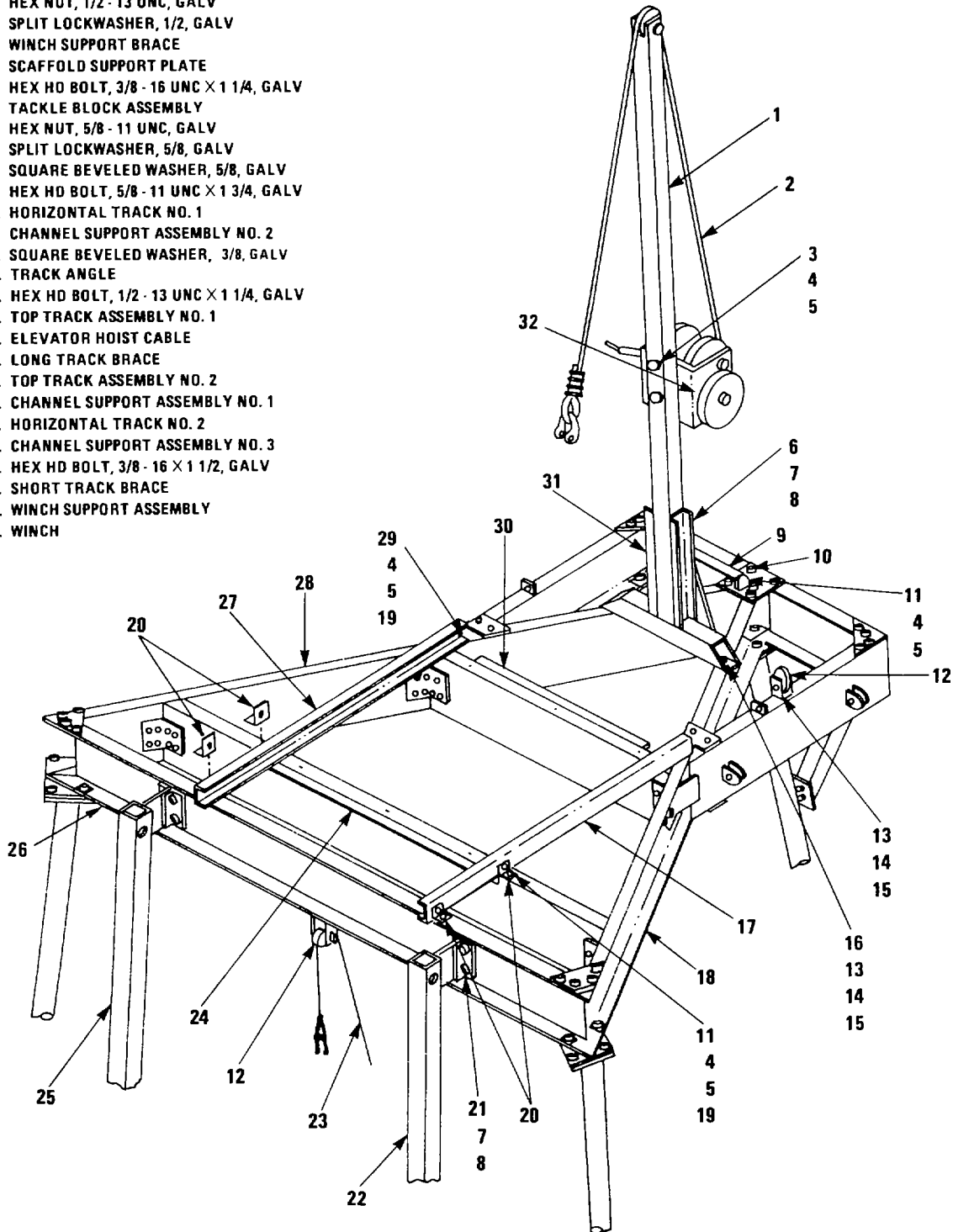

Figure 2-11. Tower Adapter with Horizontal Tracks and Scaffold Winch Assembly

(2) Attach horizontal tracks Nos. 1 (17) and 2 (27) to track angles (20) and secure with four bolts (11), nuts (4), lockwashers (5), and square beveled washers (19).

(3) Attach four bolts (29), nuts (4), lockwashers (5), and square beveled washers (19) to secure horizontal tracks Nos. 1 (17) and 2 (27) to short track brace (30) and channel support assemblies Nos. 2 (18) and 3 (28).

*c. Installation of Scaffold Winch Assembly.* The scaffold winch assembly is installed if antenna is to be attached. Refer to figure 2-11.

(1) Attach winch support assembly (31) to channel support assemblies Nos. 2 (18) and 3 (28) and secure with two bolts (16), nuts (13), lockwashers (14), and square beveled washers (15).

(2) Attach winch support (1) to winch support assembly (31). Secure with two bolts (6), nuts (7), and lockwashers (8).

(3) Attach winch (32) to winch support (1). Secure with two bolts (3), nuts (4), and lockwashers (5).

(4) Attach winch support brace (9) between winch support assembly (31) and scaffold support plate (10). Secure with two bolts (11), nuts (4), and lockwashers (5).

*d. Tower Adapter Grating Attachment.* Refer to figure 2-12. Secure tower grating assemblies (3 and 7) by the type of grating clamp assemblies (type A or type B) indicated in figure 2-12.

*e. Final Steps.* Refer to figure 2-11.

(1) If vertical elevator tracks have been installed, attach top track assemblies (22 and 25) to channel support assembly No. 1 (26). Secure with eight bolts (21), nuts (7), and lockwashers (8).

(2) Check and tighten all attaching hardware that has been installed in assembling and attaching tower adapter, including attaching hardware for scaffold winch assembly and for tower adapter grating attachment.

## 2-15 RAISING THE TOWER.

*a. Precautions.* Take the following precautions before and during tower raising operations:

(1) The truck winch and winch cable used for raising assemblies and restraining the tower during erection must have a minimum work load rating of 1 ton.

(2) There shall be at least two full wraps of cable on the drum of the tower hoist during its operation.

(3) When hoisting equipment, the operator shall not be permitted to perform any other work. He shall

not leave the controls until the load has been safely attached or safely lowered to the ground.

(4) Only the erection gear prescribed in this manual shall be used without consulting a civil engineer. All other erection and installation procedures must be approved by a civil engineer.

(5) Before tower is fully erect and tower leg comes down completely, make sure holes in flange of leg A align with studs in tower support. Correct alignment if holes and studs are not aligned. Otherwise, damage to tower leg or tower support will result.

### NOTE

**When tower is raised, make sure that cable rides in slot at top of gin pole. Gin pole will then act as lever.**

### NOTE

**Both a winch truck and tower hoist is needed for raising the tower.**

*b. Raising the Tower.*

(1) Connect cable (4, figure 2-13) from truck winch to tower adapter at legs B and C (the legs nearest the ground). Wrap this winch cable twice around each corner (B and C) and fasten to itself to form a sling with legs of equal length.

(2) Attach multiple-leg sling assembly (5, figure 2-13) to legs B and C at the bottom of tower section No. 4. See figure 2-8 for points and method of attachment.

(3) Connect one end of erection cable (6, figure 2-13) to multiple-leg sling assembly (5, figure 2-13) and the other end to the snatch block (1, figure 2-13).

(4) Secure snatch block (1, figure 2-13) to tower hoist cable. Attach this cable to eye bolt (6, figure 2-5) by means of anchor shackle (5, figure 2-5).

(5) With tower hoist, raise tower. Restrain it as it approaches the vertical position by means of winch truck.

### CAUTION

**Before tower is completely erect, check alignment of studs in tower support with mating holes in tower leg that comes down. If holes and studs do not align, correct the alignment. Otherwise damage to tower leg or tower support will result.**

(6) Before tower leg A comes completely down onto pier, make sure that the holes in this leg align with bolts in tower support.

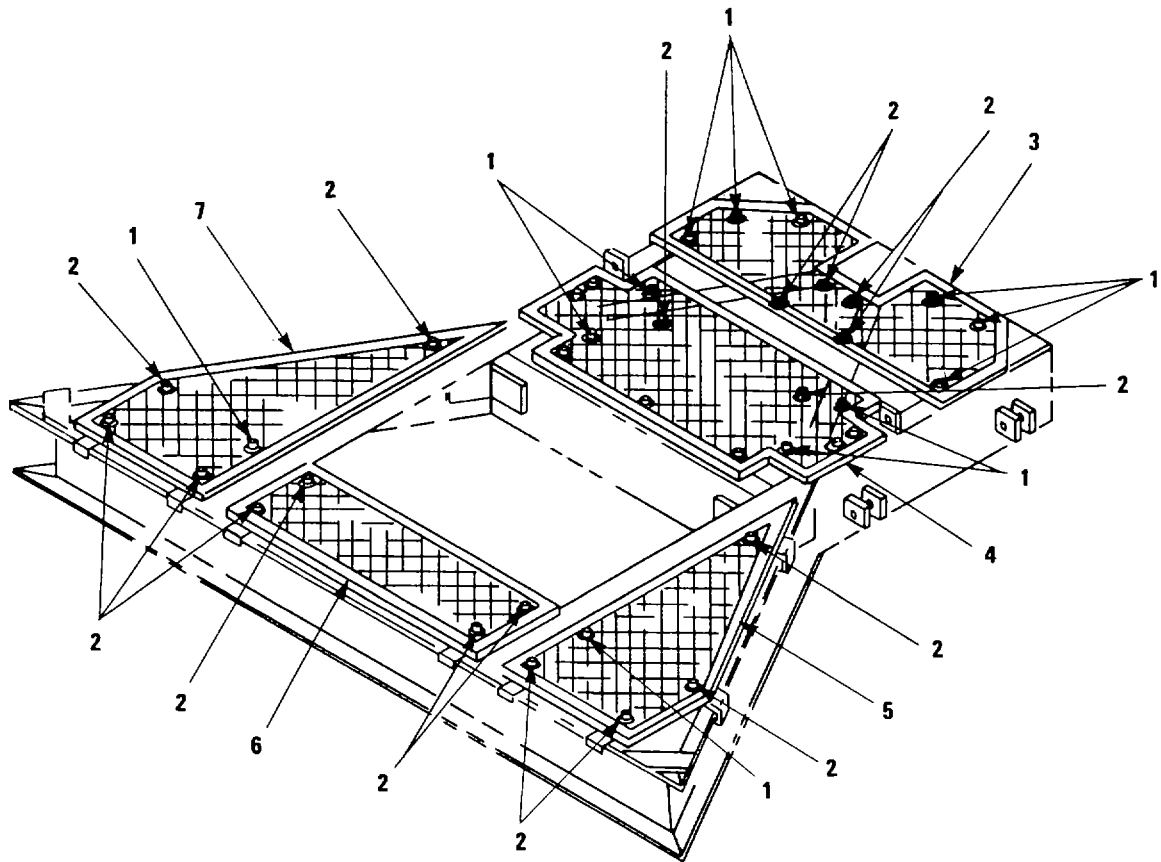

LEGEND

- 1. TYPE A GRATING CLAMP ASSEMBLY
- 2. TYPE B GRATING CLAMP ASSEMBLY
- 3. TOWER GRATING ASSEMBLY NO. 3
- 4. TOWER GRATING ASSEMBLY NO. 5
- 5. TOWER GRATING ASSEMBLY NO. 1
- 6. TOWER GRATING ASSEMBLY NO. 4
- 7. TOWER GRATING ASSEMBLY NO. 2
- 8. HEX HD BOLT, 3/8 - 16 UNC X 1 3/4, GALV
- 9. GRATING CLAMP NO. 1
- 10. SPLIT LOCKWASHER, 3/8, GALV
- 11. HEX NUT, 3/8 - 16 UNC, GALV
- 12. FLAT WASHER, 3/4, GALV
- 13. FLAT WASHER, 3/8, GALV
- 14. GRATING CLAMP NO. 2

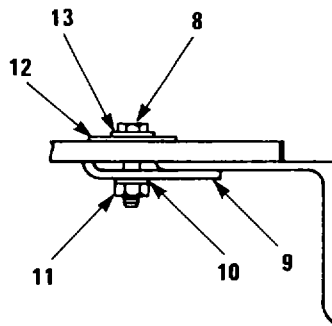

TYPE A GRATING CLAMP ASSEMBLY

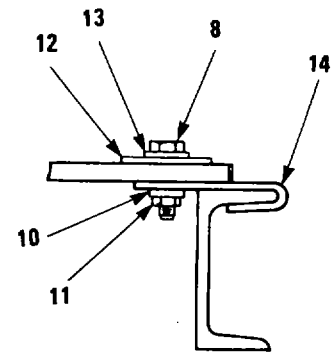

TYPE B GRATING CLAMP ASSEMBLY

Figure 2-12. Tower Grating Assemblies -Attachment

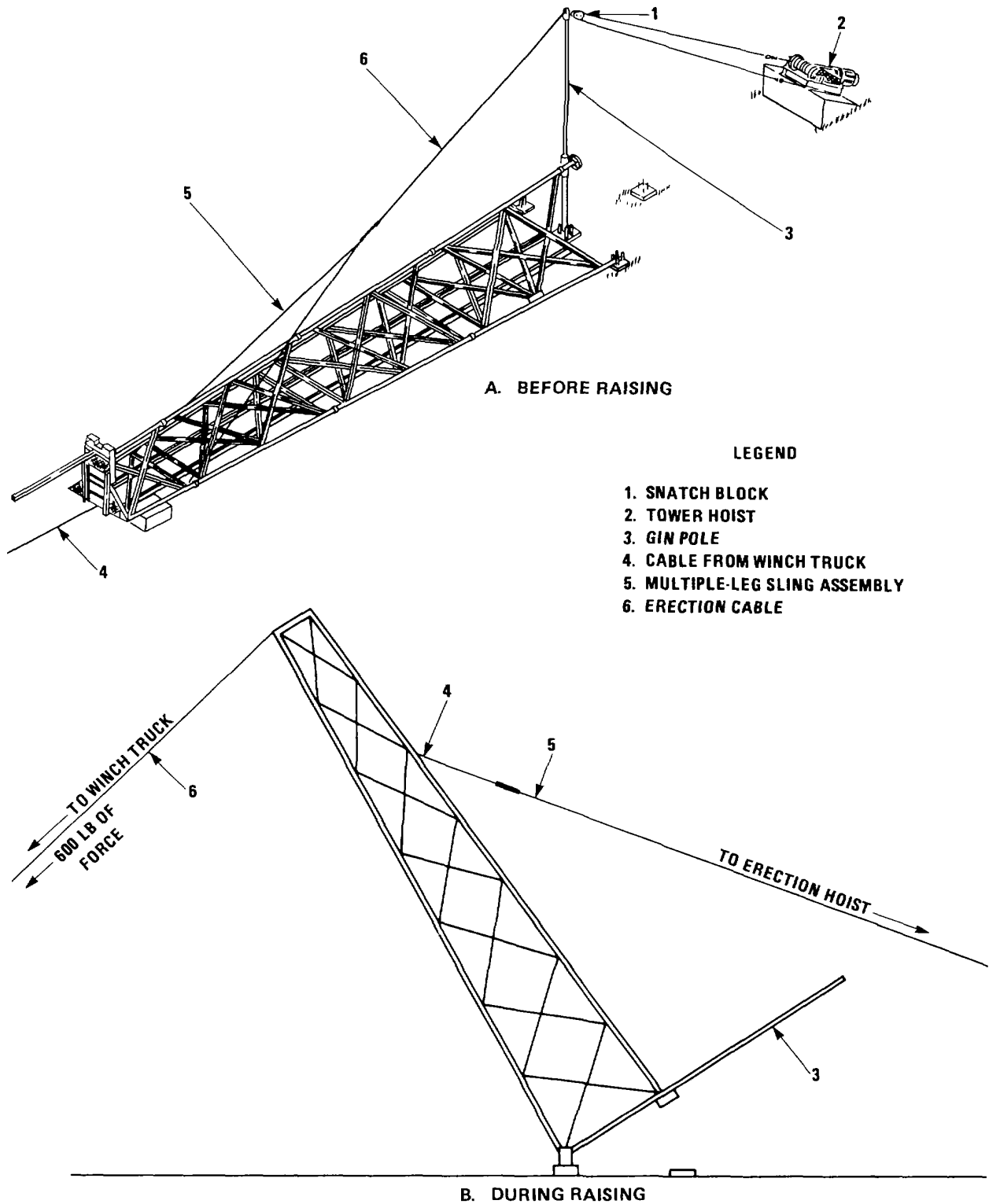

Figure 2-13. Raising Tower

(a) If bolts and holes do not align, loosen pier nuts (18, figure 2-4) on piers B and C, or loosen brace nuts, and adjust position of tower.

(b) If tower cannot be aligned by step (1), tap nuts(18,figure 2-4) on pier bolts of pier A to slightly bend these bolts and, in this way, to move tower support into position under leg A.

(7) Secure leg A (12, figure 2-6) to tower support (8, figure 2-6) with three nuts (10, figure 2-6) and lockwashers (9, figure 2-6).

c. *Installation of Tower Grounding Kit.* The tower grounding kit is installed next. Refer to figure 2-14. For each of the three tower legs, install ground rod (2).

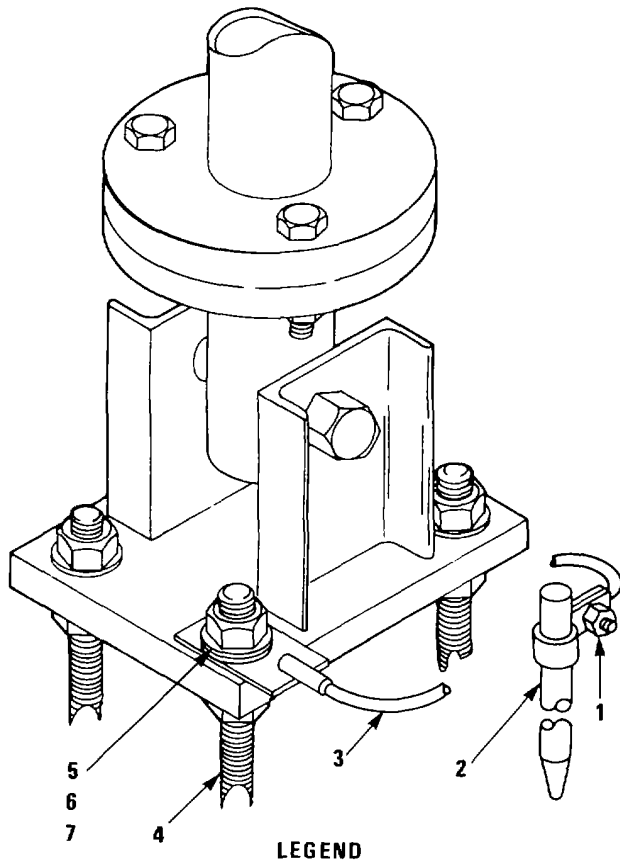

- LEGEND**
- 1. GROUND WIRE CLAMP
  - 2. GROUND ROD
  - 3. GROUND WIRE ASSEMBLY
  - 4. PIER BOLT
  - 5. HEX NUT, 1 - 8 UNC, GALV
  - 6. LOCKWASHER, 1, GALV
  - 7. FLAT WASHER, 1, GALV

Figure 2-14. Tower Grounding Kit

Connect it to the leg by ground wire assembly (3) and ground wire clamp (1). Secure to pier anchor bolt (4) with nut (5), lockwasher (6), and flat washer (7).

d. *Disassemble Gin Pole.* Refer to figure 2-6.

- (1) Remove bolt (5) and nut (6).
- (2) Remove gin pole top section (1) from gin pole bottom section (7) and from tower support (8).
- (3) Remove nut (6) from bolt (14) that goes through slot in gin pole bottom section (7). Remove this bolt from gin pole pivot base assembly (13).
- (4) Remove slotted end of gin pole bottom section (7) from gin pole pivot base assembly (13) and the other end of the gin pole bottom section (7) from pier A.
- (5) Remove four nuts (3) and the lockwashers (4) that secure the gin pole pivot base assembly (13) to gin pole pier. Remove gin pole pivot base assembly from gin pole pier.
- (6) Repack the gin pole in its original packing case, if possible.

e. *Removal of Tower Erection Equipment.*

- (1) Remove rest of tower erection equipment and store it in original packing crates, if possible, or in another protected area.
- (2) Remove truck winch line.

## 2-16 ANTENNA ELEVATOR AND CARRIAGE ASSEMBLY INSTALLATION.

a. *Precautions.* Take the following precautions before and during installation procedures:

- (1) When working on the structural tower, use safety climbing belts and hold tools and materials in containers. Pass tools and materials by using appropriate containers or ropes.
- (2) Never use the elevator erection sling to raise a structural member when this sling is supporting the member by frictional contact only. The elevator erection sling must go through a hole or be safely secured over welded track tabs when it is lifting a track or a brace.
- (3) When lifting tracks or braces, the elevator hoist operator must stand inside tower to avoid being under these members.
- (4) Do not ever use antenna elevator to lift persons. It does not have the required safety features.
- (5) When elevator is lowered, the bottom rollers of the elevator assembly must be at least 6 inches from the bottom ends of the lowest track section.

(6) Test elevator and carriage for proper operation before attaching antenna to elevator.

(7) Check gearcase of elevator hoist for proper oil level before use.

(8) Always operate controls momentarily to eliminate all slack in cable before beginning to raise or lower loads. Otherwise, starting can cause shock load, which could cause damage to hoist or to rigging.

**NOTE**

**When bottom left-hand track assembly is left free to pivot, and elevator is not to be installed immediately, temporarily secure this track assembly to bottom track support by rope or other means.**

*b. Elevator Hoist Installation.* The elevator hoist assembly is installed on the gin pole pier, with the motor nearest the tower center. Refer to figure 2-1 5.

(1) Attach elevator hoist mount (8) to gin pole pier. Secure to anchor bolts with four nuts (5), lockwashers (6), and flat washers (7).

(2) Attach elevator hoist assembly (1) to elevator hoist mount (8) and secure with six bolts (10), nuts (11), and lockwashers (12).

(3) Check gearcase of elevator hoist for proper oil level by removing red oil-level plug. Fill with oil through one of upper openings until oil reaches oil-level hole. Replace plugs tightly after this check. Check rest of elevator hoist for proper lubrication. See figure 5-2 for places to lubricate and lubricants to use.

(4) Connect hoist power.

(5) Attach hoist remote control button to either tower leg B or C. Connect remote control button to hoist control.

*c. Elevator Tracks.* The steps that follow are for installing elevator tracks after the tower has been erected. Refer to figure 2-9.

(1) Assemble tracks and supports for tower section No. 2 on the ground.

(2) Attach two track assemblies (15) to track supports Nos. 4 (11), 5 (10), and 6 (6). Secure with 12 bolts (25), nuts (17), and lockwashers (18).

(3) As in steps (1) and (2), above, assemble tracks and supports for tower section No. 3, except use track supports Nos. 7 (5), 8 (4), and 9 (3) instead of track supports Nos. 4, 5, and 6.

(4) Refer to figure 2-16. Engage tackle block assembly (10) to elevator hoist cable (8) by disassembling tackle block assembly and reassembling it with elevator hoist cable

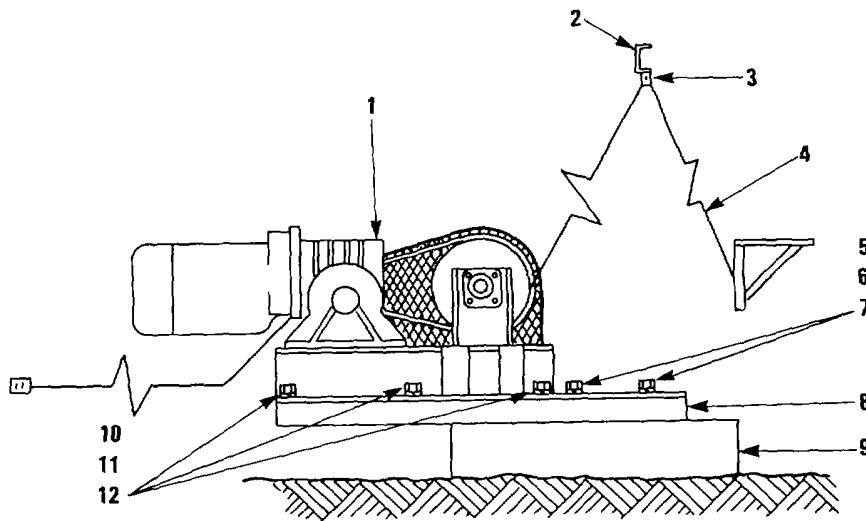

**LEGEND**

- |                                   |                                             |
|-----------------------------------|---------------------------------------------|
| 1. ELEVATOR HOIST ASSEMBLY        | 7. FLAT WASHER, 1, GALV                     |
| 2. CHANNEL SUPPORT ASSEMBLY NO. 1 | 8. ELEVATOR HOIST MOUNT                     |
| 3. TACKLE BLOCK ASSEMBLY          | 9. GIN POLE PAD                             |
| 4. ELEVATOR CABLE                 | 10. HEX HD BOLT, 5/8 - 11 UNC X 1 3/4, GALV |
| 5. NUT, 1 - 8 UNC, GALV           | 11. NUT, 5/8 - 11 UNC, GALV                 |
| 6. SPLIT LOCKWASHER, 1, GALV      | 12. LOCKWASHER, 5/8, GALV                   |

**Figure 2-15. Elevator Hoist**

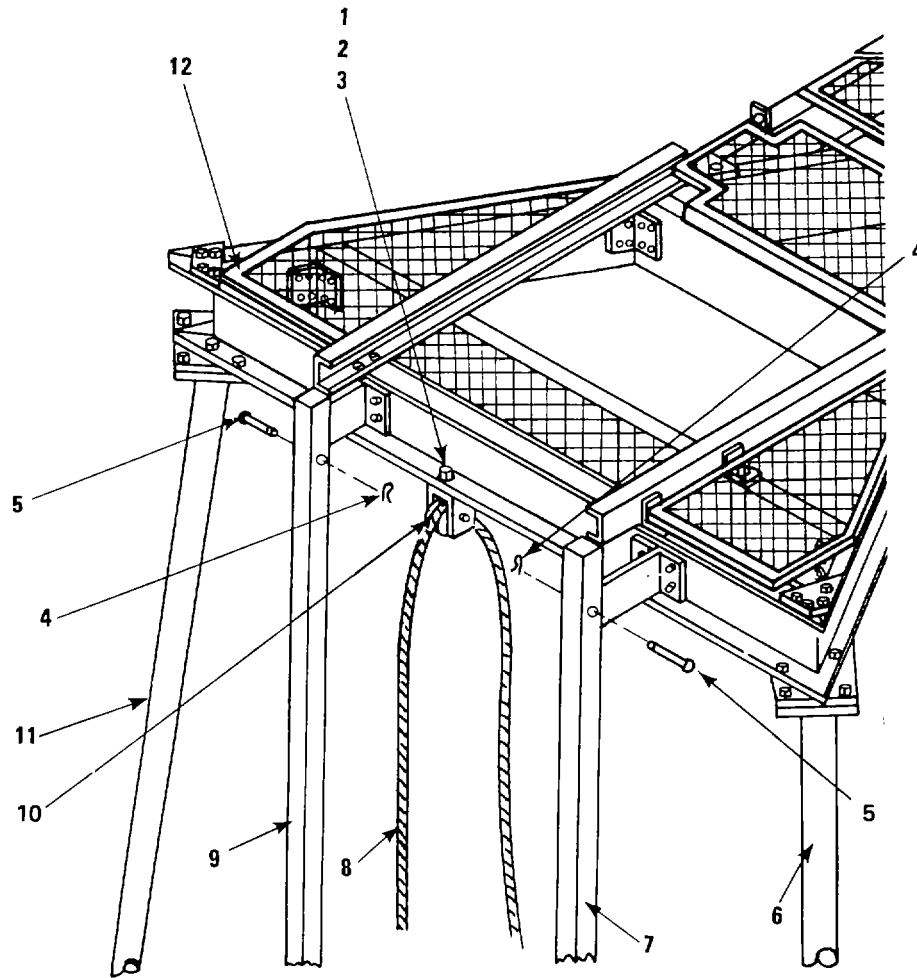

**LEGEND**

- |                                     |                                    |
|-------------------------------------|------------------------------------|
| 1. HEX NUT, 5/8 - 11 UNC, GALV      | 7. TOP TRACK ASSEMBLY NO. 1        |
| 2. SPLIT LOCKWASHER, 5/8, GALV      | 8. ELEVATOR HOIST CABLE            |
| 3. SQUARE BEVELED WASHER, 5/8, GALV | 9. TOP TRACK ASSEMBLY NO. 2        |
| 4. RETAINING PIN                    | 10. TACKLE BLOCK ASSEMBLY          |
| 5. SHEAR PIN                        | 11. TOWER LEG B                    |
| 6. TOWER LEG C                      | 12. CHANNEL SUPPORT ASSEMBLY NO. 1 |

**Figure 2-16. Top of Elevator Tracks and Tackle Block Assembly**

incorporated. To disassemble/assemble the tackle block assembly, refer to figure 2-17 and proceed as follows:

(a) To disassemble tackle block assembly, remove cotter pin (2) from bolt (6). Remove nut (3), bolt (6), two spacers (4), and sheave (5) from sheave bracket (1).

(b) To assemble tackle block assembly, place sheave (5) and spacers (4) in sheave bracket (1). Insert bolt (6) through spacers (4) and sheave (5). Put nut (3) on bolt (6). Insert cotter pin (2) in bolt (6).

(5) Refer to figure 2-16. Have a person climb tower leg B (11), carrying tackle block assembly (10) and elevator hoist cable (8) to the top. Have another person climb tower leg C (6). These two persons will work together to install the vertical elevator tracks.

(6) Refer to figure 2-16. Attach tackle block assembly (10) to channel support assembly No. 1 (12). Fasten with nut (1), lockwasher (2), and square beveled washer (3).

(7) Refer to figure 2-9. Attach rope guide assembly (21) to tower braces No. 7 (24) at the crossover junction inside tower. Fasten with bolt (22) and two nuts (23). Route elevator hoist cable through rope guide assembly, between bracket and roller. Continue with steps (8) through (12) and use figure 2-9.

**WARNING**

**Never use elevator erection sling to raise structural member when sling is supporting member by frictional contact only. Sling must go through hole or be safely secured over welded track tabs when lifting track or brace. Elevator hoist operator must stand inside tower while operating hoist, to avoid being under members being raised.**

**CAUTION**

**Before beginning to raise or lower loads, always operate controls momentarily to eliminate all slack in cable. Otherwise starting can cause shock load, which can cause damage to hoist or rigging.**

(8) Lift track support No. 10 (2) to tower section No. 4 by means of elevator erection sling (30) and tag ropes. Attach this track support to tower legs B and C and secure with two bolts (25), nuts (17), and lockwashers (18).

(a) Attach tops of top track assemblies Nos. 1 (1) and 2 (16) to tower adapter (20) and fasten with two bolts (19), nuts (17), and lockwashers (18).

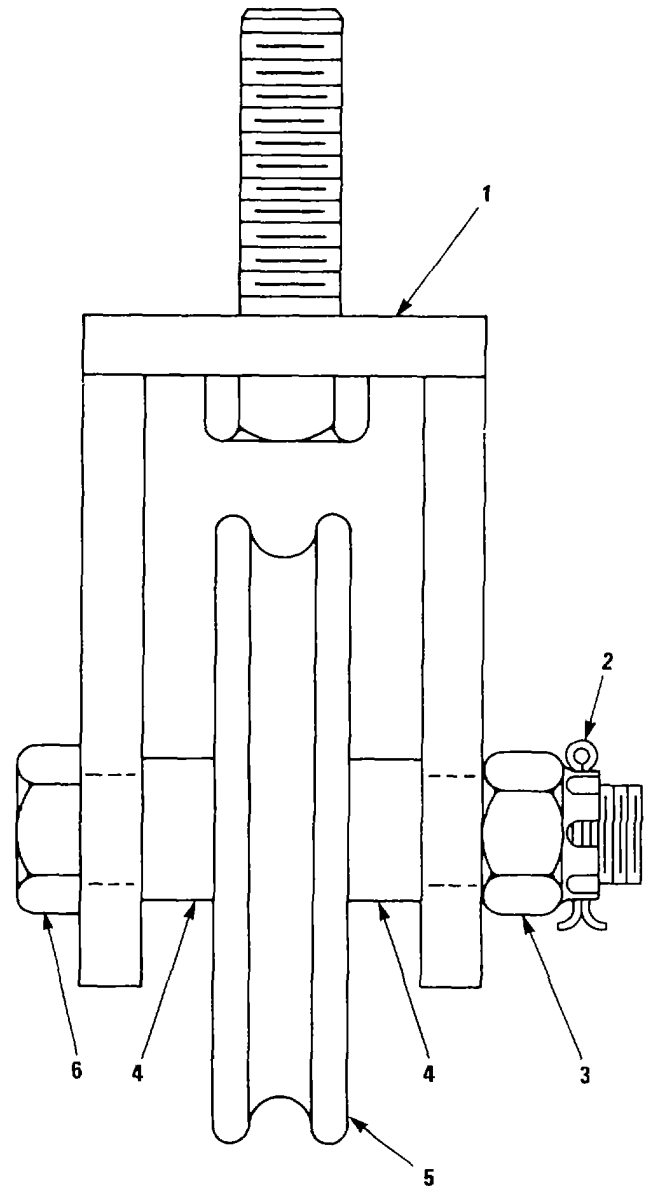

**LEGEND**

- 1. SHEAVE BRACKET
- 2. COTTER PIN, 1/8 X 1 1/2, SST
- 3. CASTLE NUT, 5/8 - 11, SST
- 4. SPACER
- 5. SHEAVE, 4 IN. DIAMETER
- 6. HEX HD BOLT, 5/8 - 11 UNC X 3 1/2, SST

**Figure 2-17. Tackle Block Assembly**



(b) Attach bottoms of these top track assemblies (1) and 16) to track support No. 10 (2) and secure with two bolts (25), nuts (17), and lockwashers (18).

(9) Raise the two track assemblies (15) and track supports 7 (5), 8 (4), and 9 (3), previously assembled on ground, to tower section No. 3. Fasten track supports 4 (1), 5 (10), and 6 (6) to tower legs with six bolts (7), nuts (8), and lockwashers (9).

(10) Align track sections of tower sections Nos. 3 and 4. The gap between tracks for the two sections should not be more than 1/16 inch. Attach splice plates (29) and secure with two bolts (26), nuts (27) and lockwashers (28).

(11) Repeat step (9) to attach track assemblies (15) and track supports 4 (11), 5 (10), and 6 (6) for tower section No. 2. Repeat step (10) to align track sections for tower sections Nos. 2 and 3 and to attach splice plates between these track sections.

(12) Track supports 3 (12), 2 (13), and 1 (14) and track assemblies (15) will be installed for tower section No. 1 next.

(a) Install, one at a time, track supports Nos. 1 (14), 2 (13), and 3 (12). Fasten with six bolts (7), nuts (8), and lockwashers (9).

(b) Attach track assembly (15) on right-hand side (as one faces tower face A). Secure with three bolts (7), nuts (8), and lockwashers (9).

(c) Align this track assembly with the one for tower section No. 2. Make sure that gap is 1/16 inch or less. Attach splice plate (29) and secure with bolt (26), nut (27), and lockwasher (28).

(d) Attach left-hand track assembly (15) by one top bolt (7), nut (8), and lockwasher (9). If elevator assembly is to be installed immediately, leave this track assembly free to pivot.

#### NOTE

**If elevator assembly is not to be installed immediately, temporarily secure bottom left-hand track assembly by rope or other means.**

*d. Elevator Assembly and Antenna Carriage Assembly.*

(1) Install elevator hoist cable and rope guide assembly (21, figure 2-9). Refer to steps (4), (6), and (7) of paragraph 2-16c.

(2) Remove the temporary tiedown that secures bottom track assembly (15, figure 2-9) on left-hand side as one faces tower face A, so that this track assembly can pivot freely.

(3) Refer to figure 2-18. Connect elevator hoist cable (1) to elevator assembly (7) by means of anchor shackle (15).

(4) Swing bottom left-hand track assembly (15, figure 2-9) away from right-hand track assembly so that elevator assembly can be installed.

(5) Refer to figure 2-9. With elevator hoist, lift elevator assembly. Mate its roller assembly with bottom right-hand track assembly.

(a) Move bottom left-hand track assembly (15) and position and mate it with roller assembly of elevator assembly.

(b) Connect left-hand track assembly (15) to track supports Nos. 1 (14) and 2 (13) by means of four bolts (7), nuts (8), and lockwashers (9).

(c) Attach remaining bolt (7), nut (8), and lockwasher (9), that secure track assembly to track support No. 3 (12).

(d) Attach remaining splice plate (29) by means of bolt (26), nut (27), and lockwasher (28).

(6) Refer to figure 2-18. Remove two stop bolts (14), nuts (9), and lockwashers (10) from horizontal track (8) elevator assembly.

(7) Refer to figure 2-18. Have two persons lift antenna carriage (13) and engage its rollers with horizontal tracks (8) of elevator assembly. It does not matter which end of antenna carriage is inserted into elevator assembly.

(8) Refer to figure 2-18. Secure antenna carriage (13) to elevator assembly (7) by means of six bolts (11), nuts (9), lockwashers (10), and square beveled washers (12). Insert two stop bolts (14), nuts (9), and lockwashers (10).

(9) Visually check to see if vertical elevator tracks are aligned. If not, align them.

(10) Perform elevator tests (paragraph 2-17b) before attaching antenna.

#### 2-17 ANTENNA INSTALLATION.

*a. Precautions.* Take the following precautions before and during antenna installation:

(1) Do not let elevator assembly go beyond its upper limit of travel. Excessive cable stress could result, which could cause equipment failure or injury to persons. Take extreme care when elevator assembly approaches this position.

(2) Because of weight differences between loaded and unloaded elevator assembly, shear pins may bind in locked position. If this binding occurs, do not attempt to force shear pins. Operate hoist to allow their removal.

(3) The bottom rollers of the elevator assembly must always be at least 6 inches from the bottom ends of the lowest track assemblies.

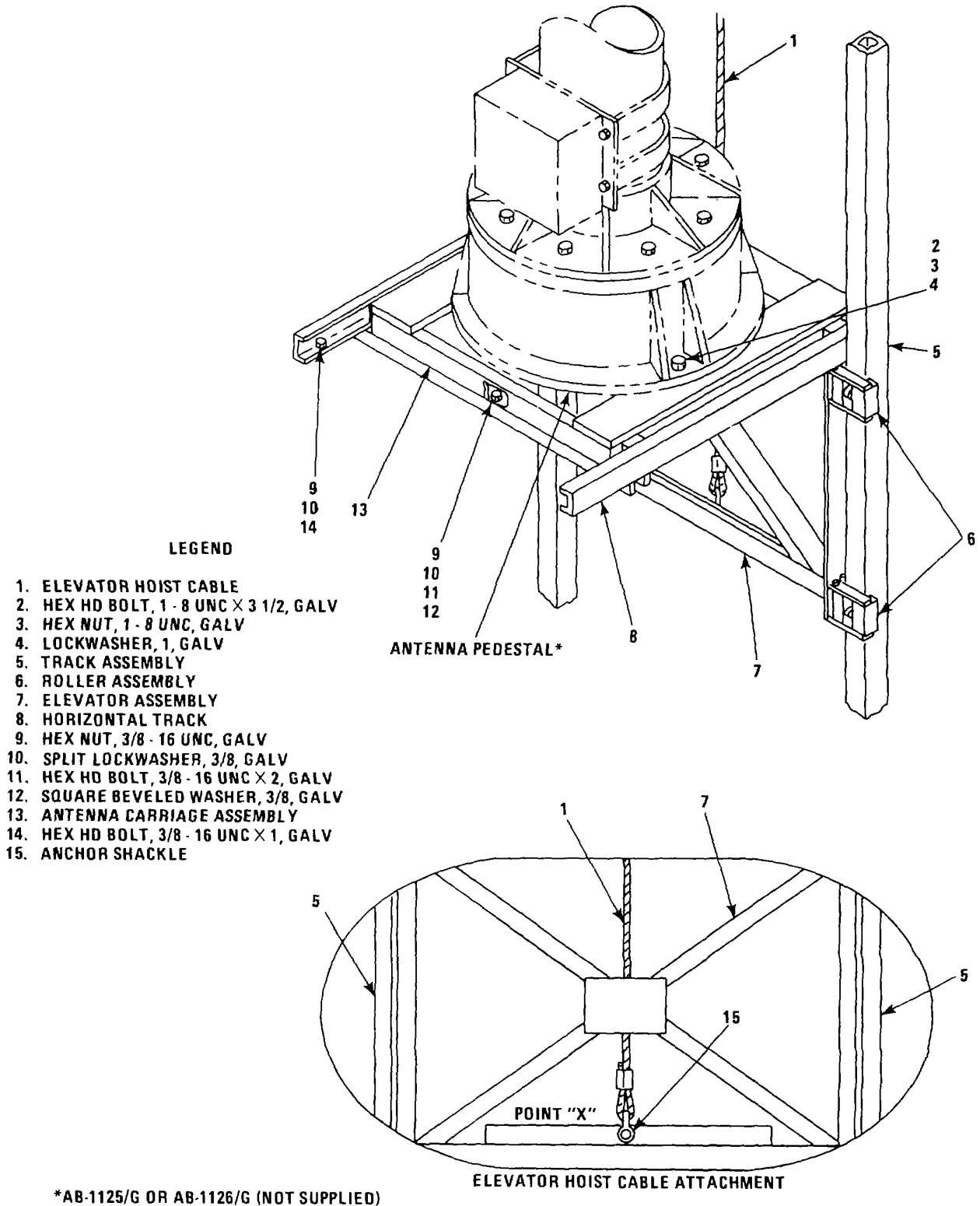

Figure 2-18. Installation of Elevator Assembly and Antenna Carriage Assembly

(4) Before attaching antenna to elevator, test elevator and carriage for proper operation.

(5) When the AN/GSA-131(V) antenna is assembled, be sure that the side that does not have elements protruding faces the tower when the antenna is attached to the antenna carriage.

(6) Before attempting to attach antenna, be sure that crank axis of tower adapter winch is parallel to tower face A. The winch will then be able to move the antenna carriage when it rides on the horizontal tracks of the tower adapter.

*b. Elevator and Carriage Tests.*

**WARNING**

**Persons must never try to ride elevator. It does not have safety features required for carrying persons.**

**CAUTION**

**Before raising or lowering load with elevator hoist, always operate controls momentarily to eliminate all slack in cable. This way, shock load and resulting damages to hoist or rigging are avoided.**

(1) With elevator hoist, begin elevator ascent. Check for smoothness of ride.

(2) Send a person to tower top with two shear pins (5, figure 2-16) and retaining pins (4, figure 2-16). This person must tell the hoist operator when the elevator assembly has reached the proper height for these shear pins to be inserted.

**WARNING**

**Do not let elevator assembly go beyond its upper limit of travel. Take extreme care when it approaches this position. Otherwise excessive cable stress could result, and this stress could cause equipment failure or injury to persons.**

(3) Raise elevator assembly to proper height with elevator hoist. Insert shear pins (5, figure 2-16) and retaining pins (4, figure 2-16).

(4) Install antenna installation platform (paragraph 2-17c) to reduce hazards and other problems in unbolting antenna carriage.

(5) Refer to figure 2-18. Remove six bolts (11), nuts (9), lockwashers (10), and square beveled washers (12) that secure antenna carriage assembly (13) to elevator assembly (7).

**NOTE**

**Tower grating assemblies above attaching hardware for horizontal tracks of tower adapter may be removed to provide access to this hardware for track alignment.**

**NOTE**

**As carriage is rolled onto tower adapter, the load on the elevator hoist cable decreases. As a result, the elevator hoist cable shortens and raises the elevator assembly slightly. To correct for the resulting misalignment of the horizontal tracks of the elevator assembly and the tower adapter, briefly operate hoist with DOWN control.**

(6) Roll antenna carriage onto horizontal tracks of tower adapter. Note and correct any condition that causes track misalignment or that prevents the six holes in the antenna carriage from perfectly mating with the holes in the tower adapter. Tower grating assemblies Nos. 1 (5, figure 2-12) and 2 (7, figure 2-12) may be removed to provide access to attaching hardware (11, 4, 5, and 19, figure 2-1 ) for adjustment of horizontal tracks (17, 27, figure 2-1 ) of tower adapter.

(7) Roll antenna carriage back onto elevator assembly. Secure with six bolts (11, figure 2-18), nuts (9, figure 2-18), lockwashers (10, figure 2-18), and square beveled washers (12, figure 2-18).

**WARNING**

**Because of weight differences between loaded and unloaded elevator assembly, shear pins may bind in locked position. If this binding occurs, do not attempt to force shear pins. Instead, operate hoist to allow their removal.**

(8) Remove shear pins (5, figure 2-16) and retaining pins (4, figure 2-16).

(9) Lower elevator. A block may be placed beneath elevator assembly after elevator has been stopped, but this block is not required.

*c. Antenna Installation Platform.* Removing and inserting attaching hardware that secures antenna carriage to elevator assembly can be difficult and hazardous when elevator assembly is at tower top. The temporary maintenance platform described in this paragraph reduces maintenance and safety problems.

(1) Horizontally bolt two aluminum channels, 4 by 4 inches by 3-1/2 feet each, to tower braces No. 7 on

tower faces B and C, in tower section No. 4, about 3 feet below base of tower adapter.

(2) Bolt flooring onto these channels. Flooring should be either 2by 6-inch fir planks of good quality or aluminum alloy plates.

*d. Antenna Attachment.*

**CAUTION**

**When antenna is assembled, be sure that side without protruding elements will face tower after antenna is attached to carriage.**

(1) The antenna to be mounted is of the AN/GSA131(V) series. Refer to TM 32-5985-201-15 for the assembly of this antenna and of the mast. As TM 32-5985-201-15 states, before it can be installed, the antenna must be built with elements protruding from three sides. The side that does not have protruding elements must be the side that faces the tower when the antenna is mounted onto the elevator.

**WARNING**

**Test elevator and carriage for proper operation and for alignment before beginning to attach antenna. Be sure that crank axis of tower adapter winch is parallel to tower face A. Then the winch can move the antenna carriage as it rides on tower adapter tracks.**

(2) Perform the elevator and carriage tests described in paragraph b, above. Check orientation of winch.

(3) Attach antenna positioner to antenna carriage as shown in figure 2-18. Secure with three bolts (2), nuts (3), and lockwashers (4).

(4) Raise antenna into position for mounting by the procedure given in TM 32-5985-201-15.

(5) Before setting antenna down, be sure that the three holes in platform of antenna carriage properly align with holes in positioner flange. If not, correct alignment.

(a) For type 1 antennas, remove positioner access cover and manually propel drive belt until holes align.

(b) For type 2 antennas, loosen locking screw. Manually turn pedestal to align holes and relock.

(6) Lower antenna mast onto pedestal. Secure with proper attaching hardware.

(7) Before raising the elevator assembly, attach the remaining antenna elements that can be attached

and that will not interfere with elevator operation. The person who attaches the antenna elements should have shear pins (5, figure 2-16) and retaining pins (4, figure 2-16) ready.

(a) Use a 20-foot ladder and tower leg ladders to reach antenna.

(b) Raise elevator assembly high enough so that one or more antenna elements can be attached by persons standing on tower leg ladders.

(c) Raise elevator assembly as often as necessary to complete antenna assembly.

(d) Use tower adapter winch to raise antenna elements to persons on tower legs ladders.

(8) Raise elevator assembly. Follow procedure given in paragraph b, steps (2) and (3), above.

(9) Install antenna installation platform (paragraph c, above) to reduce hazards and other problems in unbolting antenna carriage.

(10) Wrap two loops of cable of tower adapter winch around antenna.

(11) Crank winch to move antenna onto adapter. Secure antenna.

(12) Remove winch cable from antenna, roll carriage into position on elevator assembly, and lower elevator. Elevator assembly should be removed now. See paragraph 2-18 for procedures.

(13) Attach transmission lines to one tower leg and position cable to another tower leg. Connect transmission lines to antenna and control cable to positioner.

**2-18 REMOVAL OF ELEVATOR ASSEMBLY.**

Remove elevator assembly by procedures below. Item numbers refer to figure 2-9, unless otherwise indicated.

**WARNING**

**The bottom rollers of the elevator assembly must always be at least 6 inches from the bottom ends of lowest track section.**

**CAUTION**

**Before raising or lowering load with elevator hoist, always operate controls momentarily to eliminate all slack in cable. Otherwise shock loading may result which can cause damage to hoist or rigging.**

a. Lower elevator assembly.

b. With elevator hoist, raise elevator assembly above tower section No. 1.

c. Allow track assembly (15) on tower section No. 1 and on left-hand side (when facing tower) to freely pivot as follows:

(1) Detach splice plate (29) by removing bolt (26), nut (27), and lockwasher (28).

(2) Disconnect bottom left-hand track assembly (15) from track supports Nos. 1 (14) and 2 (13) by removing four bolts (7), nuts (8), and lockwashers (9). Remove one bolt (7), nut (8), and lockwasher (9) that connect track assembly to track support No. 3 (12).

d. Lower elevator assembly to tower section No. 1. While pivoting left-hand track, disengage it from roller assembly (6, figure 2-18) of the elevator assembly. Pivot left-hand track away from right-hand track. Disengage elevator roller assembly from right-hand track.

e. Secure bottom left-hand track assembly by rope or other temporary means. Store elevator assembly and antenna carriage in crates.

#### Section IV. PRELIMINARY ADJUSTMENT OF EQUIPMENT

##### 2-19 HOIST CONTROL.

###### **WARNING**

**High voltage is used in operation of electric hoists. Death or injury may result from contact with high voltage connections. The 230/460volt power for hoist motors and controls is lethal. Disconnect this power before servicing hoist motors or controls, or any hoist circuits.**

After the 230/460 V, three-phase, 60 Hz power is supplied to either tower or elevator hoist, direction of hoist drum rotation must be observed. See if this rotation is in the direction indicated by the control. If it is not, reverse it by interchanging any two of the three input power leads.

#### Section V. INSTALLATION AND CIRCUIT LINEUP

(No installation or circuit lineup of the Antenna Tower TS-1A is required.)

CHAPTER 3

OPERATING INSTRUCTIONS

Section I. CONTROLS AND INSTRUMENTS

**3-1 DAMAGE FROM IMPROPER SETTINGS.** Normal control settings or combinations of control settings will not cause damage to equipment or create a safety hazard.

**3-2 OPERATOR/CREW CONTROLS.**

**CAUTION**

Always push buttons momentarily to eliminate all slack in the line before trying to hoist load. Otherwise starting can cause shock loading, which can cause damage to hoist and rigging.

The only equipment that is operated after the tower is built is the tower elevator. The elevator hoist control

is a manually-operated, two-position, momentary type. See table 3-1 and figure 3-1. The remote switch is located on one of the tower legs. The UP button (for raising elevator) and the DOWN button (for lowering elevator) are separate. The hoist brake automatically holds the load when buttons are not pressed.

**Table 3-1. Operator's Controls for Elevator Hoist**

| Control | Function                                                      |
|---------|---------------------------------------------------------------|
| UP      | When pressed, raises tower elevator until button is released. |
| DOWN    | When pressed, lowers tower elevator until button is released. |

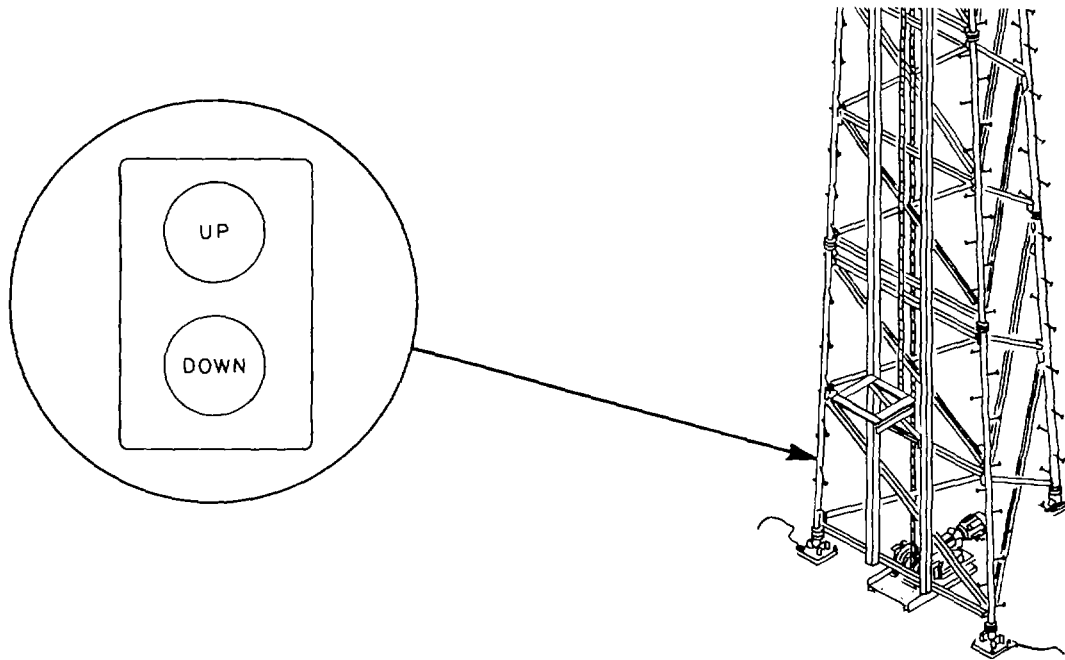

**Figure 3-1. Elevator Hoist Controls**

**Section II. OPERATION UNDER USUAL CONDITIONS**

**3-3 OPERATING PROCEDURE.** The instructions in this paragraph are for operating the elevator after the tower has been erected.

*a. Precautions.* Take the following precautions.

(1) Do not use elevator for carrying persons. It does not have the safety features required for this purpose.

(2) Do not allow elevator to travel beyond its upper limit of travel. Be very careful as it approaches this limit.

(3) Before attaching antenna to elevator, test elevator and carriage for proper operation.

(4) When elevator is lowered, bottom wheels must be at least 6 inches from bottom ends of lowest track section.

*b. Elevator Operation.*

(1) Use the remote control button, located on a tower leg, to operate the elevator hoist. See paragraph 3-2.

(2) See paragraph 2-17 for antenna installation.

(3) See paragraph 5-10b for antenna removal.

*c. Elevator Shutdown.* If elevator is not to be used (after antenna has been completely installed or completely removed), shut down hoist as follows:

(1) Lower elevator. After elevator stops, a block may be placed under elevator assembly.

(2) Turn elevator hoist ON-OFF switch to OFF.

**Section III. OPERATION UNDER UNUSUAL CONDITIONS**

**3-4 GENERAL.** It may be necessary to operate the tower under conditions of extreme cold, heat, humidity, moisture, sand, or wind. The tower is designed to be operational in temperatures ranging from -20° to +1200F.

**3-5 OPERATION IN ARCTIC CLIMATES.** Temperatures and weather conditions associated with arctic climate can affect the efficient operation of the equipment. Handle parts carefully, especially wire insulation and plastics which become brittle at subzero temperatures. When equipment is exposed to cold air, moisture will condense on it and icing conditions can result.

**3-6 OPERATION IN DESERT CLIMATES.** The main problem arising in desert operation is large amounts of sand, dust, and dirt which may affect operation of the equipment. Clean assemblies thoroughly before

replacing them. Make frequent preventive maintenance checks. Excessive amounts of dust and sand that come in contact with lubricants will damage moving parts. Hoist operation in a dusty or sandy atmosphere requires the use of lubricants designed for this purpose.

**3-7 OPERATION IN TROPICAL CLIMATES.** When equipment is operated in warm, damp climates, moisture conditions are acute. High relative humidity may cause condensation on equipment and accelerate corrosion. Make frequent maintenance checks.

**3-8 OPERATION IN HIGH WINDS.** High wind conditions present a hazard to both equipment and personnel. The Antenna Tower TS-IA has been designed to withstand high winds. (For tower wind loading capability, refer to paragraph 1-9.)

**Section IV. PREPARATION FOR MOVEMENT**

**3-9 PROCEDURE.** The tower must be disassembled before movement to a new site. New piers must be prepared at the new site before reassembly and

reinstallation of the tower. Refer to paragraphs 5-11 and 2-12.

**CHAPTER 4**

**OPERATOR/CREW MAINTENANCE INSTRUCTIONS**

(There are no operator/crew maintenance instructions for this equipment.)

**4-1/(4-2 Blank)**



CHAPTER 5

ORGANIZATIONAL MAINTENANCE INSTRUCTIONS

Section I. TOOLS AND EQUIPMENT

**5-1 TOOLS AND MATERIALS.** Tools required for organizational maintenance are listed in Appendix D, Maintenance Allocation Chart. Refer to Appendix F for

expendable materials and supplies. Tools and materials required for organizational maintenance are listed in table 5-1.

**Table 5-1. Organizational Maintenance Tools and Materials**

| Item                        | Use                                                                                                                                   |
|-----------------------------|---------------------------------------------------------------------------------------------------------------------------------------|
| Allen wrench, 3/8-inch      | Removing and tightening socket head screws.                                                                                           |
| Torque wrench, 0-200 ft-lbs | Tightening attaching hardware.                                                                                                        |
| Torque wrench, 0-600 ft-lbs | Tightening attaching hardware.                                                                                                        |
| Bristle brush, 1-inch       | Removing dust and dirt from hard-to-reach areas of metal parts and applying trichloroethane to remove caked-on dirt from metal parts. |
| Cloth, lint-free            | Removing dust and dirt from metal parts.                                                                                              |
| Trichloroethane             | Cleaning caked-on dirt and grease from metal parts.                                                                                   |

Section II. REPAINTING AND REFINISHING INSTRUCTIONS

**5-2 GENERAL.** The tower is often exposed to weather conditions (rain, snow, and ice) that cause rust and corrosion of the tower elements. Repaint or refinish these parts when extensive rust and corrosion are found during routine and periodic maintenance inspections.

Painting and Preserving Electronics Command Equipment Including Camouflage Pattern Painting of Electrical Equipment Shelters, shall be followed to repaint the tower units. The paints and finishes shall be those specified in SB 11-573, Painting and Preservation Supplies Available for Field Use for Electronics Command Equipment. Refer also to TM 43-0139, Painting Instructions for Field Use.

**5-3 PROCEDURES AND MATERIALS.** The procedures given in TB 43-0118, Field Instructions for

**Section III. LUBRICATION INSTRUCTIONS**

**5-4 GENERAL.** Keep all lubricants in closed containers and store in a clean, dry place away from external heat. Do not allow dust, dirt, or other foreign material to mix with the lubricants. Keep all lubrication equipment clean and ready to use. Keep all external parts that do not require lubrication free of lubricants. Before lubricating equipment, wipe all lubrication points free of dirt and grease. Clean all lubricated points after lubrication to prevent accumulation of foreign matter. Service the lubricated points at proper intervals as shown in figures 5-1 through 5-5, and in accordance with the instructions for the elevator and tower hoists in paragraph 5-5, below.

a. Refer to tables 5-2 and 5-3 for recommended lubricants. Check gearcase for proper oil level by removing red oil-level plug. Fill with oil through one of the upper openings until oil reaches oil level hole, then replace plugs tightly.

b. Change gearcase lubricant after first 250 hours of use and every 1,500 hours of operation after this initial period with Mobil Temp 78.

c. All viscosity group 318.63 lubricants must be changed after 300 hours of high-temperature operation.

d. Proper lubrication with specified lubricants is particularly important in arctic and desert climates.

**5-5 ELEVATOR AND TOWER ELECTRIC HOISTS.**

Refer to figure 5-2.

**Table 5-2. Lubricant Viscosity Groups for Electric Hoists**

| Ambient temperature | Lubricant viscosity group |              |
|---------------------|---------------------------|--------------|
|                     | 300 rpm or less           | Over 300 rpm |
| -65° to 0° F*       | 318.59                    | -            |
| -45° to +200° F*    | 318.60                    | 318.59       |
| -5° to +55° F*      | 318.61                    | 318.60       |
| +15° to +1100° F    | 318.62                    | 318.62       |
| +100° to +165° F    | 318.63**                  | 318.63**     |

\*For temperatures below +10° F, special oil seals are required.

\*\*All lubricants of viscosity group 318.63 must be changed after 300 hours of high-temperature operation.

**Table 5-3. Lubricants Recommended for Electric Hoists**

| Viscosity group | Lubricant          |
|-----------------|--------------------|
| 318.59          | Avrex 903          |
| 318.60          | Mobil Fluid 423    |
| 318.61          | Mobil Oil Co. HD90 |
| 318.62          | Mobil Oil Co. 600W |
| 318.63*         |                    |

\*All lubricants of viscosity group 318.63 must be changed after 300 hours of high-temperature operation.

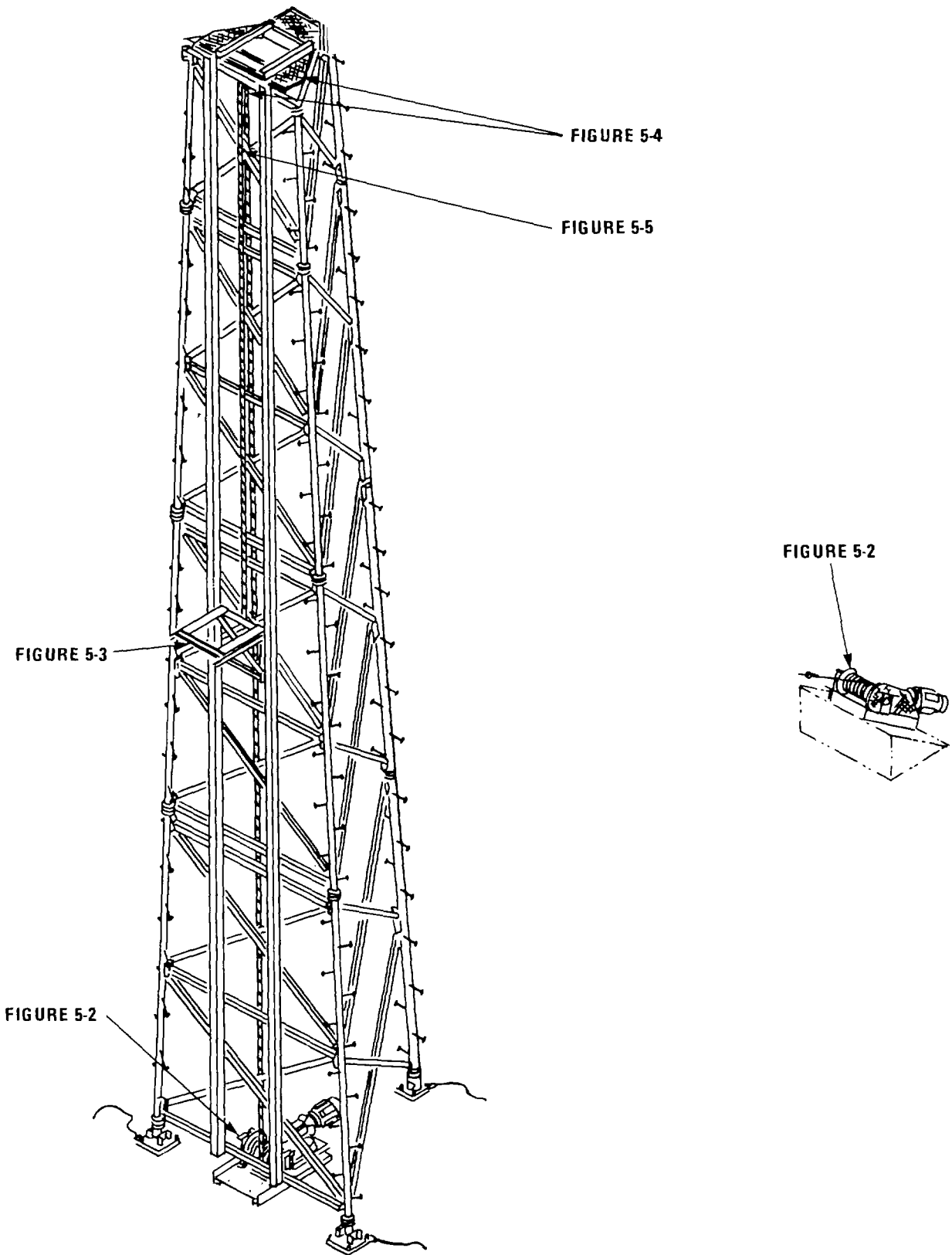
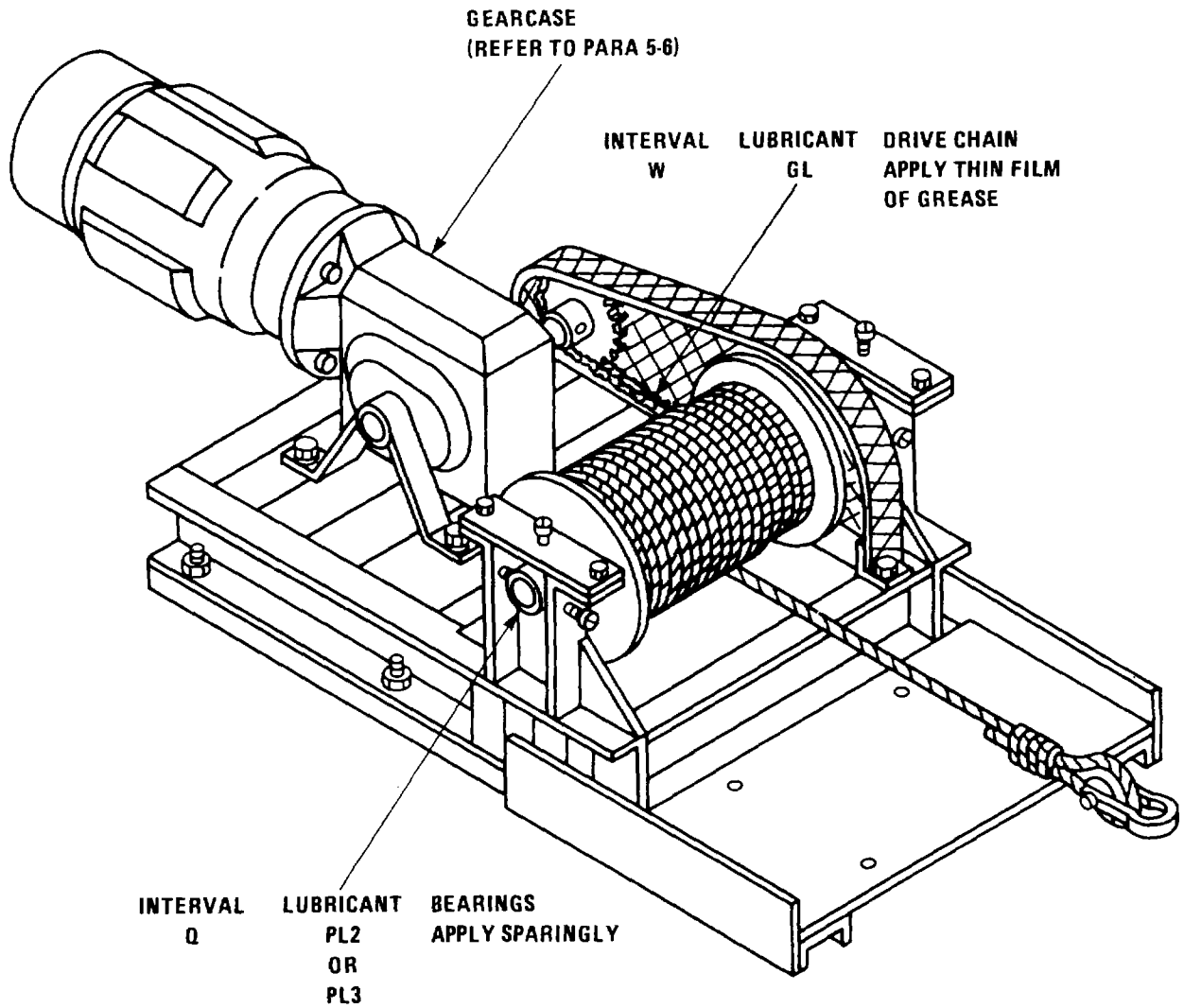

Figure 5-1. Antenna Tower TS-1A Lubrication



KEY

| LUBRICANTS                             | INTERVALS               |
|----------------------------------------|-------------------------|
| GL - GREASE<br>MOBIL TEMP 78           | W-WEEKLY<br>Q-QUARTERLY |
| PL2 - OIL<br>ALVANIA EPI<br>BELOW 32°F |                         |
| PL3 - OIL<br>ALVANIA EP2<br>ABOVE 32°F |                         |

Figure 5-2. Elevator Hoist and Tower Hoist Lubrication Chart

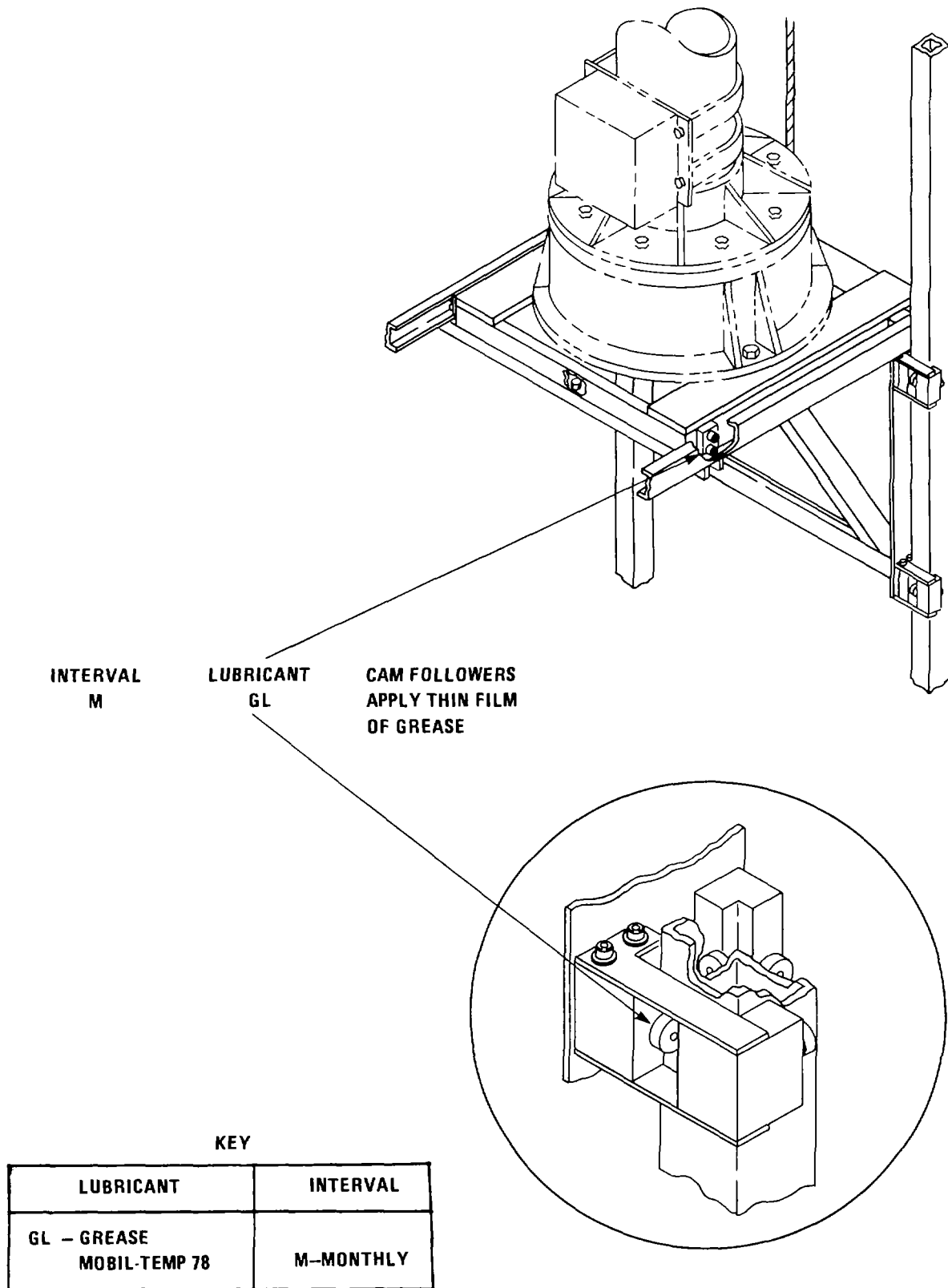

Figure 5-3. Lubrication Chart for Elevator Assembly and Antenna Carriage

| INTERVAL | LUBRICANT |
|----------|-----------|
| Q        | PL        |
| M        | GL        |
| Q        | PL        |

SHEAVE  
APPLY SPARINGLY  
TO BEARINGS

WINCH  
APPLY SPARINGLY  
TO INTERFACING  
GEARS

BLOCK ASSEMBLIES  
APPLY SPARINGLY  
TO BEARINGS

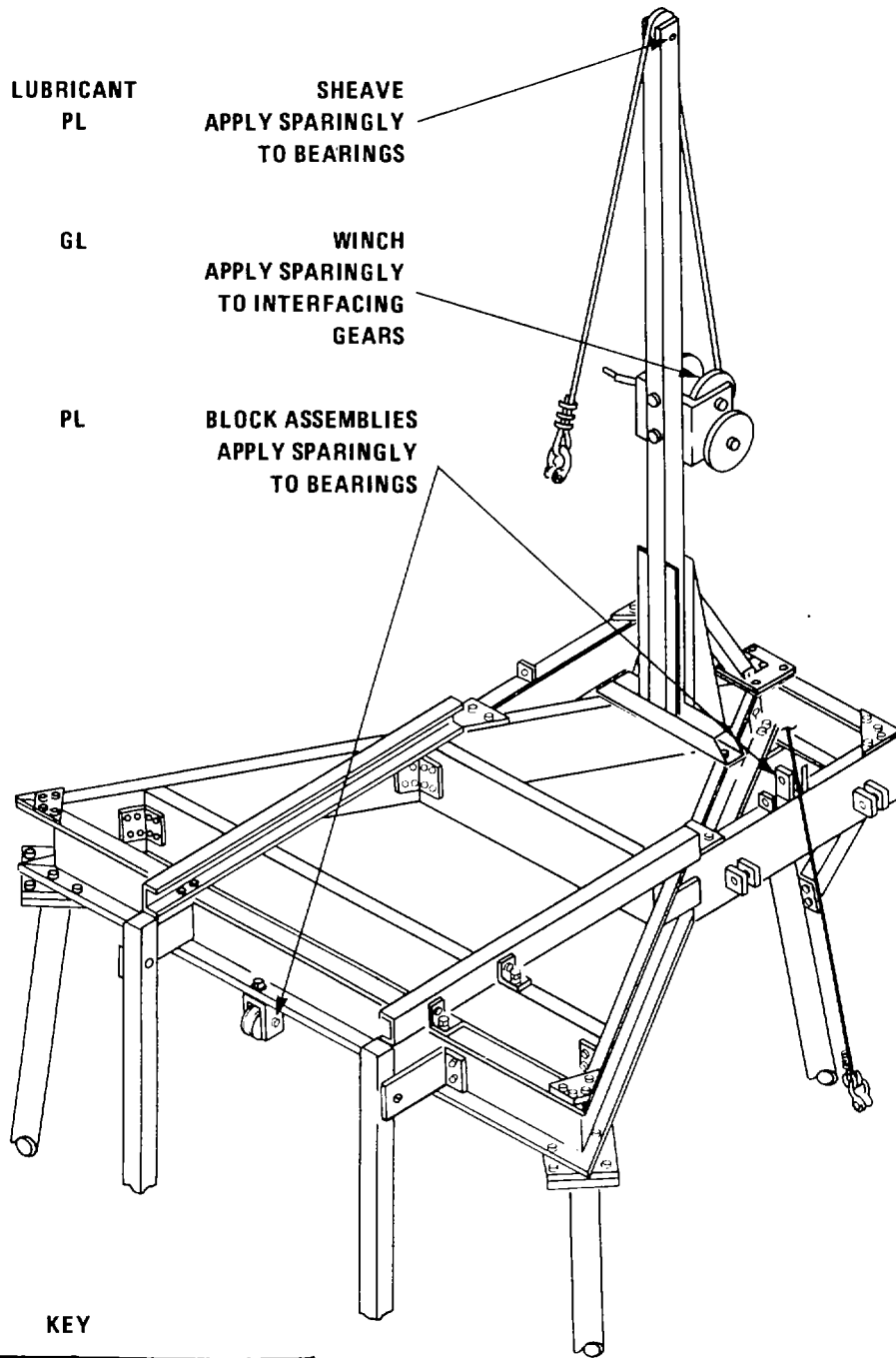

KEY

| LUBRICANTS                    | INTERVALS                |
|-------------------------------|--------------------------|
| PL - OIL<br>SAE 30 WT         | M-MONTHLY<br>Q-QUARTERLY |
| GL - GREASE<br>MOBIL TEMP 78° |                          |

Figure 5-4. Tower Adapter Lubrication Chart

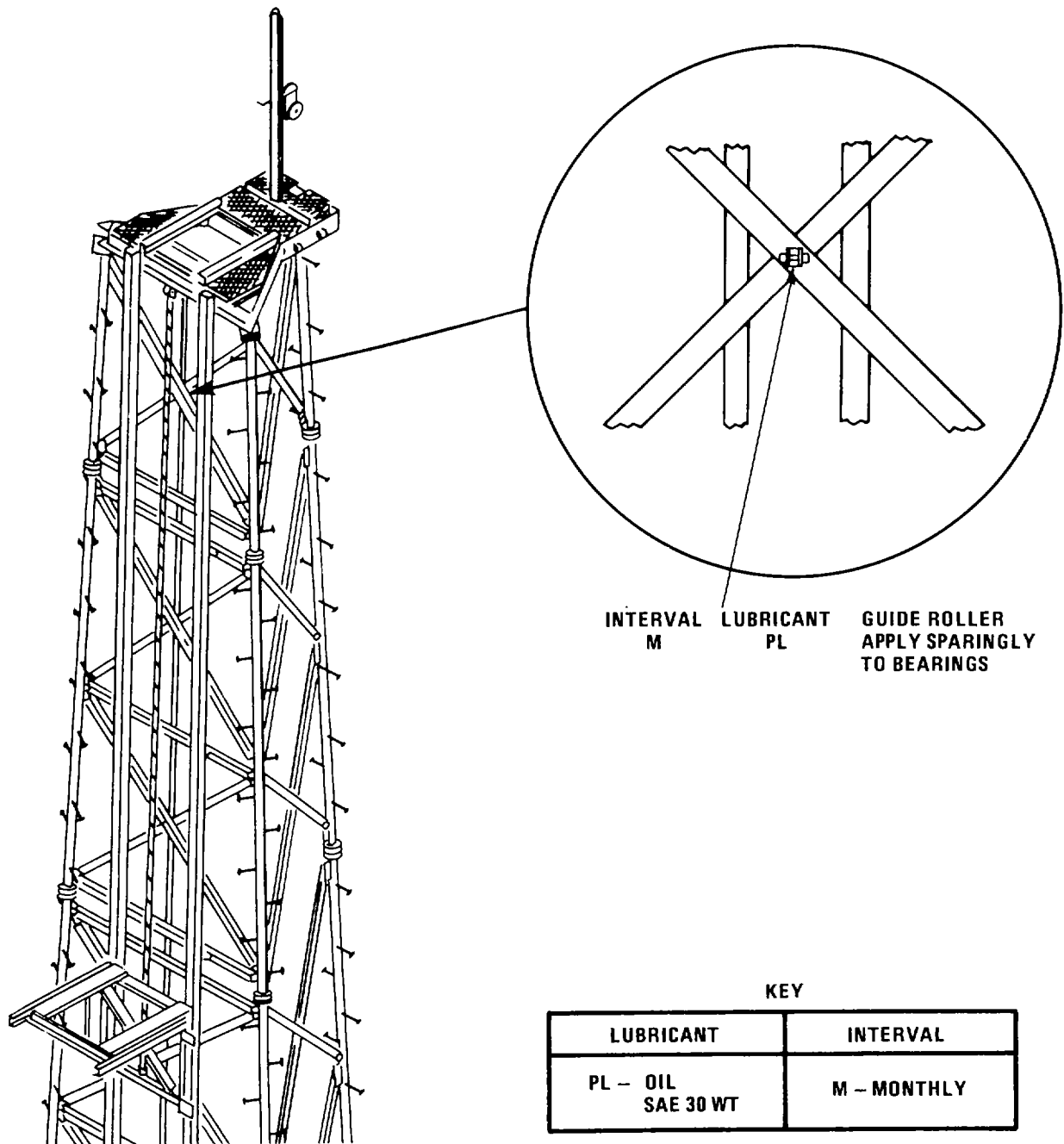

Figure 5-5. Rope Guide Assembly Lubrication Chart

**Section IV. PREVENTIVE MAINTENANCE CHECKS AND SERVICES (PMCS)**

**5-6. PMCS PROCEDURES.** To be sure that the Antenna Tower TS-1A is fully operational at all times, it must be inspected periodically and systematically. Defects can then be discovered and corrected before they result in serious damage to the tower or antenna. Necessary preventive maintenance checks and services are listed in table 5-4. Take the tower out of service immediately if a deficiency is noted that would endanger the structure or would damage the equipment. Record all deficiencies and corrective actions on forms and records specified in TM 38-750.

**5-7. SPECIAL INSTRUCTIONS.** Some environments require more preventive maintenance checks and services than those given in paragraph 5-6.

*a. Desert Climates.* Check frequently for problems created by large amounts of sand, dust, and dirt. One of these problems is damage to moving parts from grit produced when sand, dust, and dirt mix with lubricants.

*b. Tropical Climates.* Check frequently for problems produced by moisture, such as condensation on equipment and accelerated corrosion.



**Table 5-4. Organizational Preventive Maintenance Checks and Services Legend**

W - Weekly  
M - Monthly

Q - Quarterly  
S - Semiannually

A - Annually  
B - Biennially

H - Hours  
MI - Miles

| Item No. | Interval |   |   |   |   |   |   |    | Item To Be Inspected    | Procedures                                                                                                                                                                                                                                                                | Equipment will be reported Not Ready (Red) if: |
|----------|----------|---|---|---|---|---|---|----|-------------------------|---------------------------------------------------------------------------------------------------------------------------------------------------------------------------------------------------------------------------------------------------------------------------|------------------------------------------------|
|          | W        | M | Q | S | A | B | H | MI |                         |                                                                                                                                                                                                                                                                           |                                                |
| 1        | •        |   |   |   |   |   |   |    | SCAFFOLD WINCH ASSEMBLY | a. Check assembly for physical damage.<br>b. Tighten all loose bolts, nuts, clamps, braces, and mounting hardware.<br>c. Check for rust and corrosion.<br>d. Clean scaffold winch assembly.                                                                               |                                                |
| 2        | •        |   |   |   |   |   |   |    | ELEVATOR HOIST          | a. Check for physical damage.<br>b. Check hoist control for proper operation of hoist.<br>c. Check power cable for kinks and strains.<br>d. Tighten all loose bolts, nuts, clamps, and mounting hardware.<br>e. Check for rust and corrosion.<br>f. Clean elevator hoist. |                                                |
| 3        |          |   | • |   |   |   |   |    | TOWER                   | a. Check for physical damage.<br>b. Tighten all loose bolts, nuts, clamps, braces, and tower steps.<br>c. Check elevator track alignment.<br>d. Check for rust and corrosion.                                                                                             |                                                |
| 4        | •        |   |   |   |   |   |   |    | GROUND CONNECTIONS      | a. Tighten all loose bolts, nuts, and clamps.<br>b. Clean ground connections.                                                                                                                                                                                             |                                                |

Table 5-4. Organizational Preventive Maintenance Checks and Services

| Item No. | Interval |   |   |   |   |   |   |    | Item To Be Inspected              | Procedures                                                                                                                                                 | Equipment will be reported Not Ready (Red) if: |
|----------|----------|---|---|---|---|---|---|----|-----------------------------------|------------------------------------------------------------------------------------------------------------------------------------------------------------|------------------------------------------------|
|          | W        | M | Q | S | A | B | H | MI |                                   |                                                                                                                                                            |                                                |
| 5        |          |   | • |   |   |   |   |    | TOWER PIER BASES                  | Check for settling.<br><br>NOTE<br><b>Immediate corrective action shall be taken if pier settling is evident. Request assistance from civil engineers.</b> |                                                |
| 6        |          |   | • |   |   |   |   |    | PUBLICATIONS                      | Check that all publications are complete, serviceable, and current (including all current publication changes).                                            |                                                |
| 7        |          |   | • |   |   |   |   |    | MODIFICATIONS WORK ORDERS (MWO'S) | Determine whether new applicable MWO's have been published. All URGENT MWO's must be applied immediately; all NORMAL MWO's must be scheduled.              |                                                |

\*Use this column as a source of item numbers for the "TM Number" column on DA Form 2404, Equipment Inspection and Maintenance Worksheet, used to record the results of the PMCS.

Section V. TROUBLESHOOTING

5-8. TROUBLESHOOTING TABLE.

**WARNING**

High voltage is used in operation of electric hoists. Death or injury may result from contact with high voltage connections. The 230/460-volt power for hoist motors and controls is lethal. Disconnect this power before servicing hoist motors or controls, or any hoist circuits.

Table 5-5 gives information for locating and correcting troubles with the tower at the organizational level of maintenance. Specific parts concerned are the tower and the elevator hoists and the elevator. Each malfunction listed is followed by checks or inspections and corrective actions. Perform these checks or inspections in the order listed. Any trouble that is beyond the scope of organizational maintenance shall be referred to direct support maintenance.

Table 5-5. Organizational Troubleshooting Chart

---

**MALFUNCTION**

**TEST OR INSPECTION**

**CORRECTIVE ACTION**

---

**1. ELEVATOR HOIST DOES NOT FUNCTION WHEN CONTROL BUTTON IS PRESSED.**

Step 1. Check to see if power supply cord is disconnected.

**Connect power cord to power supply receptacle.**

Step 2. Check for loose power cable connections.

**Tighten connections.**

Step 3. Inspect power cable for defects.

**Replace power cable if defective.**

Step 4. Inspect hoist operating control for defects.

**Replace hoist operating control if defective.**

Step 5. Inspect control cable for defects.

**Replace control cable if defective.**

Step 6. Inspect hoist motor for defects.

**Replace hoist motor if defective.**

Table 5-5. Organizational Troubleshooting Chart-Continued

| MALFUNCTION                                                                                     | TEST OR INSPECTION                                                                                                                                                                 | CORRECTIVE ACTION                             |
|-------------------------------------------------------------------------------------------------|------------------------------------------------------------------------------------------------------------------------------------------------------------------------------------|-----------------------------------------------|
| <b>2. DIRECTION OF HOIST DRUM ROTATION IS OPPOSITE OF DIRECTION INDICATED BY HOIST CONTROL.</b> |                                                                                                                                                                                    |                                               |
| Step 1.                                                                                         | Interchange any two of input power leads to control. (See paragraph 2-19.) Check that resulting direction of drum rotation is now the same as that indicated by the hoist control. |                                               |
| Step 2.                                                                                         | If, after interchanging input power leads, drum continues to rotate in opposite direction, refer to higher level of maintenance.                                                   |                                               |
| <b>3. ELEVATOR ASSEMBLY OR CARRIAGE DOES NOT RIDE SMOOTHLY ON TRACKS.</b>                       |                                                                                                                                                                                    |                                               |
| Step 1.                                                                                         | Inspect tracks for alignment.                                                                                                                                                      |                                               |
|                                                                                                 |                                                                                                                                                                                    | <b>Realign all tracks if necessary.</b>       |
| Step 2.                                                                                         | Check for loose cam follower hardware.                                                                                                                                             |                                               |
|                                                                                                 |                                                                                                                                                                                    | <b>Tighten all cam follower hardware.</b>     |
| Step 3.                                                                                         | Inspect cam follower blocks for defects.                                                                                                                                           |                                               |
|                                                                                                 |                                                                                                                                                                                    | <b>Replace defective cam follower blocks.</b> |

**Section VI. MAINTENANCE OF ANTENNA TOWER TS-1A**

**5-9. GENERAL.** This section contains instructions for organizational maintenance of the Antenna Tower TS-1A. Organizational maintenance includes:

- a. Removal and replacement of parts and antenna.
- b. Disassembly of major components.
- c. Cleaning of all equipment.

**5-10. REMOVAL.**

a. *Safety Precautions.* Observe the following precautions before and during maintenance of the tower. Refer to paragraph 2-11 for additional precautions.

(1) Do not use tower or elevator hoists as hoists for persons. Required safety devices are not provided for these hoists.

(2) When working on structural tower, use safety climbing belts and hold tools and materials in containers. Pass tools and materials by using appropriate containers or ropes.

(3) Truck winch and winch cable must have a minimum work load rating of 1 ton. Winch truck must be capable of effectively braking, lowering, and safely holdings this 1-ton load.

(4) There shall be at least two full wraps of cable on drum of tower hoist during its operation.

(5) Blocks that support lowered tower with tower adapter attached must be capable of supporting at least 2,000 pounds.

(6) When hoisting equipment, hoist operator shall not be permitted to perform any other work. He shall not leave controls until load has been safely lowered to the ground.

(7) Do not let elevator assembly go beyond its upper limit of travel. Damage to equipment or injury to personnel could result. Be very careful as elevator approaches this limit. Have someone at tower top to tell elevator hoist operator when elevator reaches upper limit.

(8) When elevator is lowered, bottom roller assemblies of elevator assembly must be at least 6 inches from bottom of lowest track section.

(9) When antenna is lowered, be sure that side of antenna that faces tower does not have protruding elements that would interfere with elevator motion.

#### **NOTE**

**When tower is lowered, be sure that cable rides in cable slot at top of gin pole. Gin pole will then act as lever.**

*b. Antenna.* Item numbers that follow refer to figure 5-6, unless indicated otherwise.

(1) Install elevator assembly. Refer to paragraph 2-16d.

#### **CAUTION**

**Before raising or lowering load with elevator hoist, always operate controls momentarily to eliminate all slack in cable. Otherwise starting can cause shock load which could cause damage to hoist or to rigging.**

(2) Test elevator for proper operation.

See paragraph 2-17b.

(3) Disconnect transmission lines from antenna and control cable from positioner.

#### **CAUTION**

**When antenna is lowered, be sure that side of antenna that faces tower does not have protruding elements that would interfere with elevator motion.**

(4) The antenna may be lowered with elements protruding from the three sides that do not face tower. Detach all elements from side facing tower that would interfere with elevator motion. Refer to TM 32-5985-201-15. Scaffold winch may be used to lower antenna elements to ground.

#### **WARNING**

**Do not let elevator assembly go beyond its upper limit of travel. Take extreme care when it approaches this position. Otherwise excessive cable stress could result, and this stress could cause equipment failure or injury to persons.**

(5) Raise elevator to top and secure with shear pins and retaining pins. See paragraph 2-17b, steps (2) and (3).

(6) Install temporary antenna installation platform (paragraph 2-17c) to reduce hazards and other problems in bolting and unbolting carriage.

(7) Roll carriage onto elevator. To prevent misalignment between elevator and tower tracks that would result from the load on the elevator stretching the elevator cable, briefly operate hoist with UP control. Secure with six bolts (20), nuts (21), lockwashers (22), and square beveled washers (23).

(8) Remove antenna installation platform.

#### **WARNING**

**When elevator is lowered, bottom roller assemblies of elevator assembly must be at least 6 inches from bottom of lowest track section.**

(9) Remove shear pins and retaining pins previously inserted. With elevator hoist, lower elevator.

(10) Remove remaining elements that must be removed before antenna can be detached from elevator. Raise and lower elevator when necessary. Use 20-foot ladder and tower leg ladders to reach antenna.

(11) Remove antenna and pedestal from elevator. Refer to TM 32-5985-201-15.

(12) If elevator is not to be used soon, remove elevator assembly and carriage. Refer to paragraph 2-18.

*c. Antenna Carriage Assembly.* Refer to figure 5-6.

(1) Remove two stop bolts (25), nuts (21), and lockwashers (22) from horizontal tracks (18) of elevator assembly.

(2) Detach carriage assembly (24) from elevator assembly (17) by removing six bolts (20), nuts (21), lockwashers (22), and square beveled washers (23).

(3) Have two persons roll carriage assembly (24) off horizontal tracks (18) of elevator assembly and disengage roller assemblies (16).

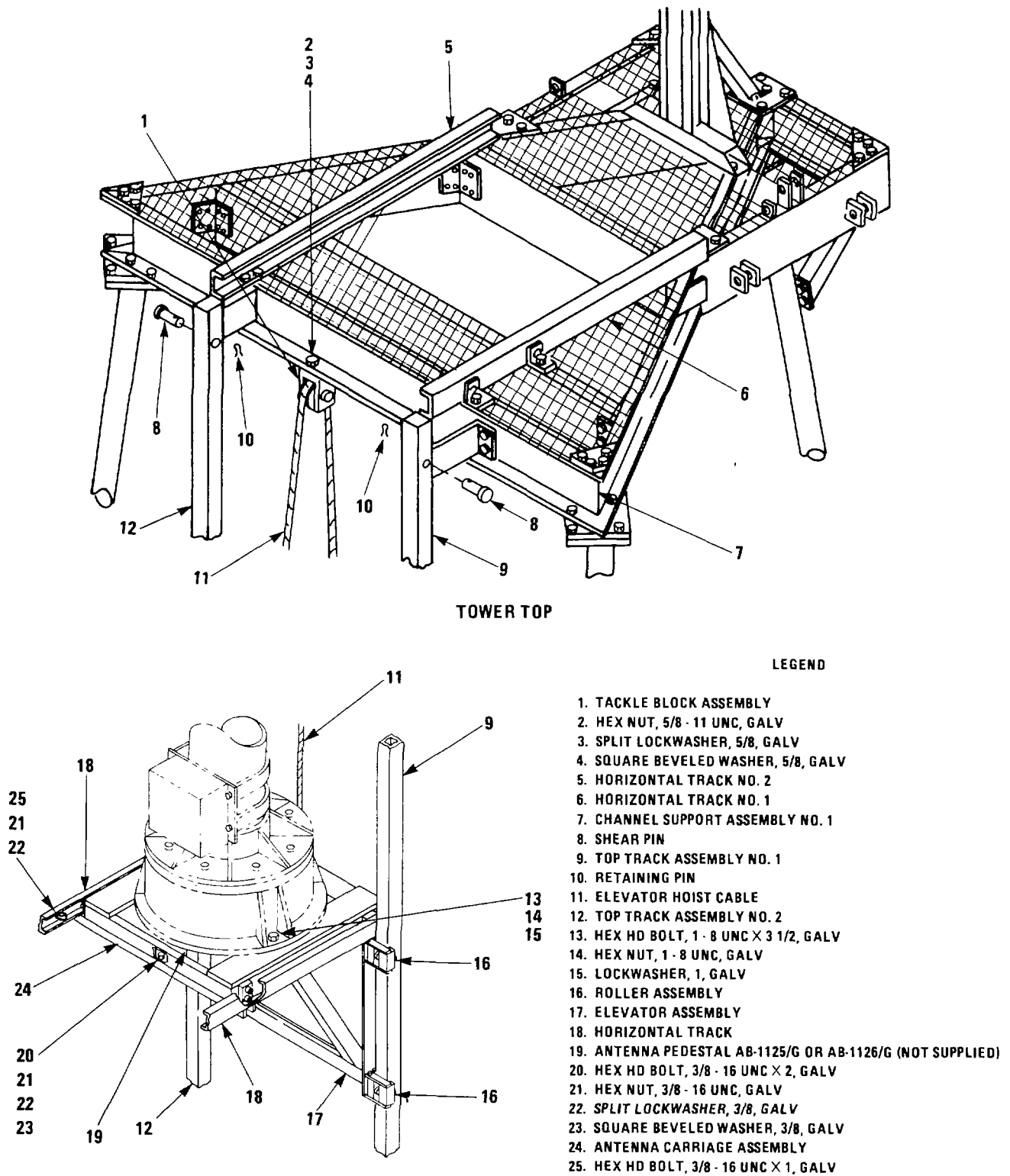

Figure 5-6. Elevator and Carriage Assemblies

(4) Attach stop hardware to horizontal tracks (18) of elevator assembly with two bolts (25), nuts (21), and lockwashers (22).

*d. Elevator Assembly.* Refer to paragraph 2-18.

*e. Elevator Hoist.* Refer to figure 5-7, unless otherwise indicated.

(1) Remove elevator assembly (paragraph 2-18).

(2) Have two persons work simultaneously to remove elevator hoist cable from tower. Have one climb tower leg B and the other tower leg C, each carrying a tag rope.

(3) Remove elevator hoist line from rope guide assembly (5), on crossover point of tower braces No. 7 (4), on tower section No. 4.

(4) Tie tag rope to elevator hoist cable (2) at point close to tackle block assembly (1) located on channel support assembly No. 1 (3) of tower adapter.

(5) Detach tackle block assembly (1, figure 5-6) from channel support assembly No. 1 (7, figure 5-6) by removing nut (2, figure 5-6), lockwasher (3, figure 5-6), and square beveled washer (4, figure 5-6).

(6) With tag rope, lower tackle block assembly and hoist cable to ground. Remove tag rope.

(7) To remove hoist cable from tackle block assembly, disassemble tackle block assembly, remove hoist cable, and assemble tackle block assembly. Refer to paragraph 2-16c, step (4).

(8) Wind elevator hoist cable (2) onto hoist drum (17). Disconnect hoist power.

(9) Remove six bolts (9), nuts (10), and lockwashers (11) that connect elevator hoist mount assembly (15) to elevator hoist mount (16). Remove elevator hoist (8) and elevator hoist mount assembly (15).

(10) Detach elevator hoist mount (16) from concrete pier by removing four nuts (12), lockwashers (13), and flat washers (14).

*f. Elevator Tracks With Tower Erect.* Refer to figure 5-8.

(1) *Preliminary Steps.* Perform following steps before removing any tracks:

(a) Remove elevator assembly as described in paragraph 2-18.

(b) Perform the procedures in paragraph 5-10e, steps (1) through (7), above.

(c) Have two persons with two tag lines and elevator erection sling (25) climb tower to highest tracks to be removed. These persons will work together to remove tracks.

### **WARNING**

**Never use elevator erection sling to raise structural member when sling is supporting member by frictional contact only. Sling must go through hole or be safely secured over welded track tabs when lifting track or brace. Elevator hoist operator must stand inside tower while operating hoist, to avoid being under members being lowered.**

### **WARNING**

**When working on structural tower, use safety climbing belts and hold tools and materials in proper containers. Pass tools and materials by using appropriate containers or ropes.**

(2) *Top Elevator Tracks.*

(a) Detach two splice plates (24) that connect top track assemblies Nos. 1 (1) and 2 (16), on tower section No. 4, to track assemblies (4) on tower section No. 3 by removing eight bolts (18), nuts (19), and lockwashers (20).

(b) Unfasten top track assemblies Nos. 1 (1) and 2 (16) from channel support assembly No. 1 (17) by removing eight bolts (18), nuts (19), and lockwashers (20).

(c) Detach top track assemblies Nos. 1 (1) and 2 (16) from track support No. 10 (2) by removing four bolts (21), nuts (19), and lockwashers (20).

(d) Detach track support No. 10 (2) from tower legs by removing two bolts (12), nuts (13), and lockwashers (14).

(e) With tag ropes and elevator erection sling (25), lower top track assemblies and track support to ground.

(3) *Tracks for Tower Sections Nos. 1, 2, and 3.*

(a) If not previously removed, detach upper two splice plates by removing four bolts (21), nuts (19), and lockwashers (20). For tower sections Nos. 2 and 3, detach lower two splice plates in the same manner.

(b) Detach three track supports (3, 5, and 6; 7, 8, and 9; or 15, 10, and 11) from tower legs by removing six bolts (12), nuts (13), and lockwashers (14).

(c) With tag ropes and elevator erection hoist (25), lower assembly of tracks and supports to ground.

*g. Rope Guide Assembly.* Refer to figure 5-7. The rope guide assembly (5) is located at the crossover point of tower braces No. 7 (4) in tower section No. 4. Detach rope guide assembly by removing bolt (6) and nut (7).

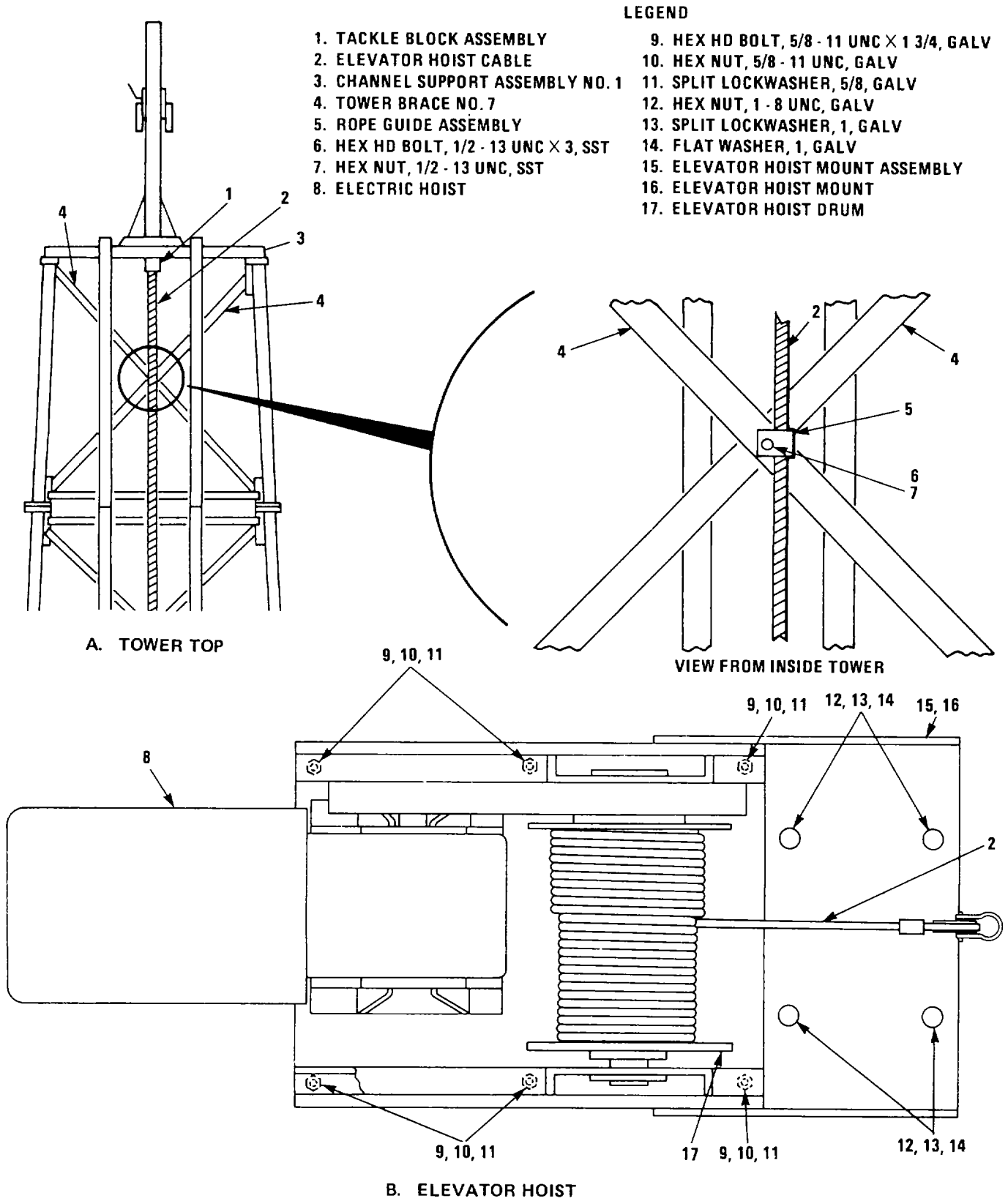

Figure 5-7. Elevator Hoist, Cable, and Rope Guide Assembly



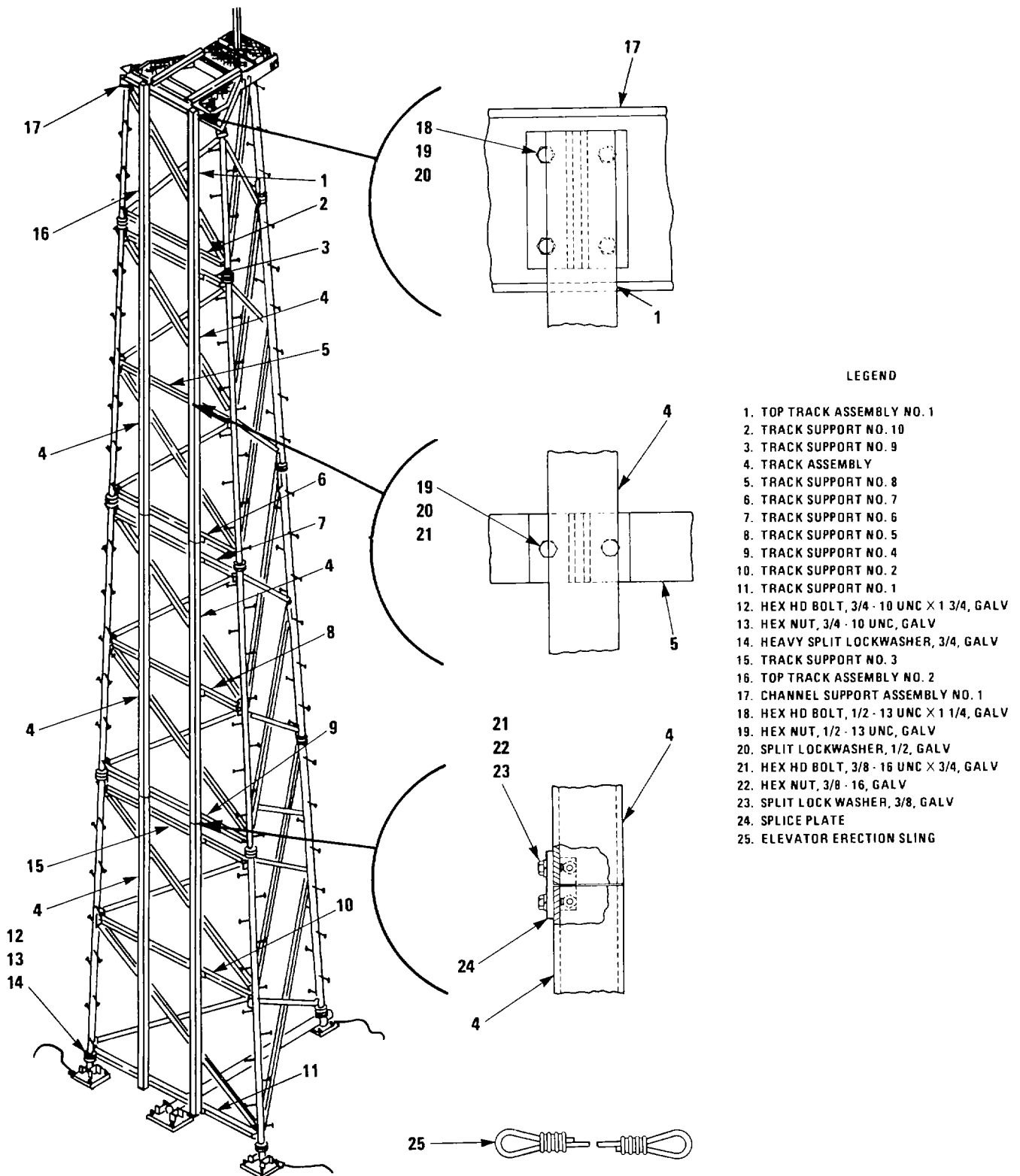

Figure 5-8. Elevator Tracks

*h. Lowering Tower.* The tower must be lowered before the tower adapter or any tower section can be removed. A 1-ton winch truck will be needed. Refer to figure 5-9.

- (1) Remove the following:
  - (a) Antenna (paragraph 5-10b).
  - (b) Antenna carriage assembly (paragraph 5-10c).
  - (c) Elevator assembly (paragraph 2-18).
  - (d) Elevator hoist (paragraph 5-10e).
- (2) Assemble gin pole on gin pole pier. See paragraph 2-12d.
- (3) Install tower hoist. See paragraph 2-12b.

**WARNING**

**Truck winch and hoist cables must have minimum workload rating of 1 ton. Winch truck must be able to effectively brake, lower, and safely hold this 1-ton load.**

(4) Park 1-ton winch truck at least 75 feet from face A of tower.

(a) Attach trunk winch cable (13) from winch truck to tower adapter (14) at tower legs B (12) and C (11).

(b) Wrap truck winch cable (13) twice around each corner B and C and fasten it to itself to form a sling with legs of equal length.

(5) Attach multiple-leg sling assembly (1) to tower legs B (12) and C (11) at bottom of tower section No. 4. See detail in figure 5-9.

(6) Remove four nuts (19) and lockwashers (20) that secure tower support (6) to pier A and remove one flat washer (21) and ground wire assembly (22).

(7) Lower tower.

(a) With winch truck, start pivoting tower, and with tower hoist (3), restrain tower until it is horizontal.

(b) As gin pole (5) and erection cable (2) come together, make erection cable (2) engage cable slot at top of gin pole.

(c) Make sure that erection cable rides in that slot as tower is lowered further.

(8) Place blocks under legs B (12) and C (11) approximately 2 feet from top of tower section. These blocks must be able to support 2,000 pounds and should be high enough to keep tower horizontal.

(9) Remove all truck winch and tower hoist rigging from tower.

*i. Elevator Tracks With Tower Lowered.* Refer to figure 5-8.

(1) Detach six splice plates (24) from six track assemblies (4) and top track assemblies Nos. 1 (1) and 2 (16) by removing 12 bolts (21), nuts (22), and lockwashers (23).

(2) Detach six track assemblies (4) from track supports Nos. 1 through 9 (11, 10, 15, 9, 8, 7, 6, 5, and 3) by removing 36 bolts (21), nuts (19), and lockwashers (20).

(3) Detach top track assemblies Nos. 1 (1) and 2 (16) from track support No. 10 (2) by removing four bolts (21), nuts (19), and lockwashers (20), and detach top track assemblies Nos. 1 (1) and 2 (16) from channel support assembly No. 1 (17), on tower adapter by removing eight bolts (18), nuts (19), and lockwashers (20).

(4) Detach track supports Nos. 1 through 9 (11, 10, 15, 9, 8, 7, 6, 5, and 3) by removing 20 bolts (12), nuts (13), and lockwashers (14).

*j. Tower Grating Assemblies.* Refer to figure 5-10. Remove 17 type A grating clamp assemblies (3) and 16 type B grating clamp assemblies (2) by removing, for each, bolt (8), nut (11), lockwasher (10), flat washers (12 and 13), and type A or type B grating clamp (9 or 14). Remove tower grating assemblies Nos. 1 through 5 (5, 7, 1, 6, and 4).

*k. Scaffold Winch Assembly.* Refer to figure 2-11.

(1) Detach winch support brace from scaffold support plate (10) and from scaffold winch assembly (31) by removing two bolts (11), nuts (4), and lockwashers (5).

(2) Detach winch (32) from winch support (1) by removing two bolts (3), nuts (4), and lockwashers (5).

(3) Detach winch support (1) from winch support assembly (31) by removing two bolts (6), nuts (7), and lockwashers (8).

(4) Detach winch support assembly (31) from channel support assemblies Nos. 2 (18) and 3 (28) by removing two bolts (16), nuts (13), lockwashers (14), and square beveled washers (15).

*l. Horizontal Tracks of Tower Adapter.* Refer to figure 2-11.

(1) Detach horizontal tracks Nos. 1 (17) and 2 (27) from short track brace (30) and channel support assemblies Nos. 2 (18) and 3 (28) by removing four bolts (29), nuts (4), lockwashers (5), and square beveled washers (19).

(2) Detach horizontal tracks Nos. 1 (17) and 2 (27) from four track angles (20) by removing four bolts (11), nuts (4), lockwashers (5), and square beveled washers (19).

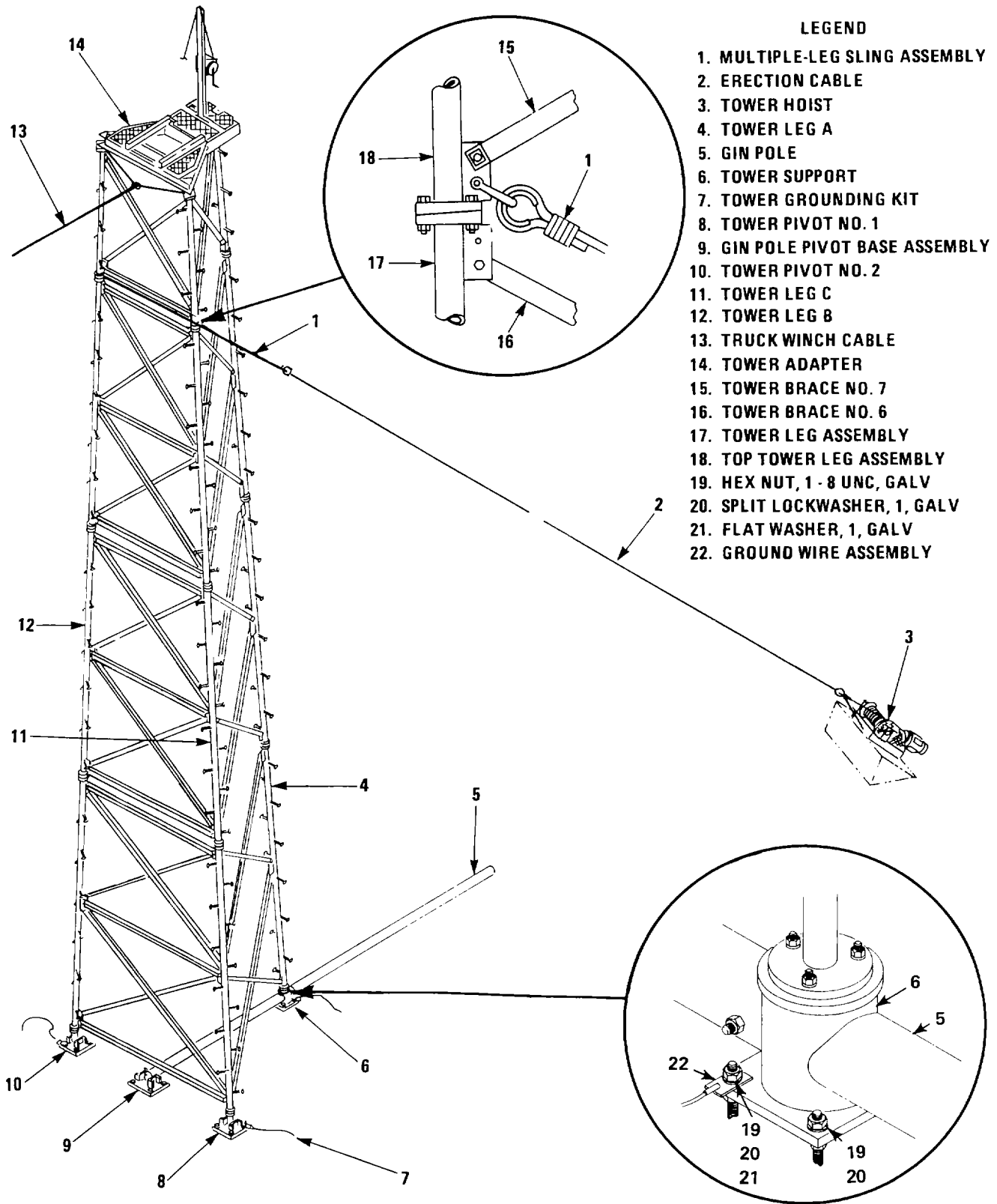

**LEGEND**

- 1. MULTIPLE-LEG SLING ASSEMBLY
- 2. ERECTION CABLE
- 3. TOWER HOIST
- 4. TOWER LEG A
- 5. GIN POLE
- 6. TOWER SUPPORT
- 7. TOWER GROUNDING KIT
- 8. TOWER PIVOT NO. 1
- 9. GIN POLE PIVOT BASE ASSEMBLY
- 10. TOWER PIVOT NO. 2
- 11. TOWER LEG C
- 12. TOWER LEG B
- 13. TRUCK WINCH CABLE
- 14. TOWER ADAPTER
- 15. TOWER BRACE NO. 7
- 16. TOWER BRACE NO. 6
- 17. TOWER LEG ASSEMBLY
- 18. TOP TOWER LEG ASSEMBLY
- 19. HEX NUT, 1 - 8 UNC, GALV
- 20. SPLIT LOCKWASHER, 1, GALV
- 21. FLAT WASHER, 1, GALV
- 22. GROUND WIRE ASSEMBLY

Figure 5-9. Lowering Tower

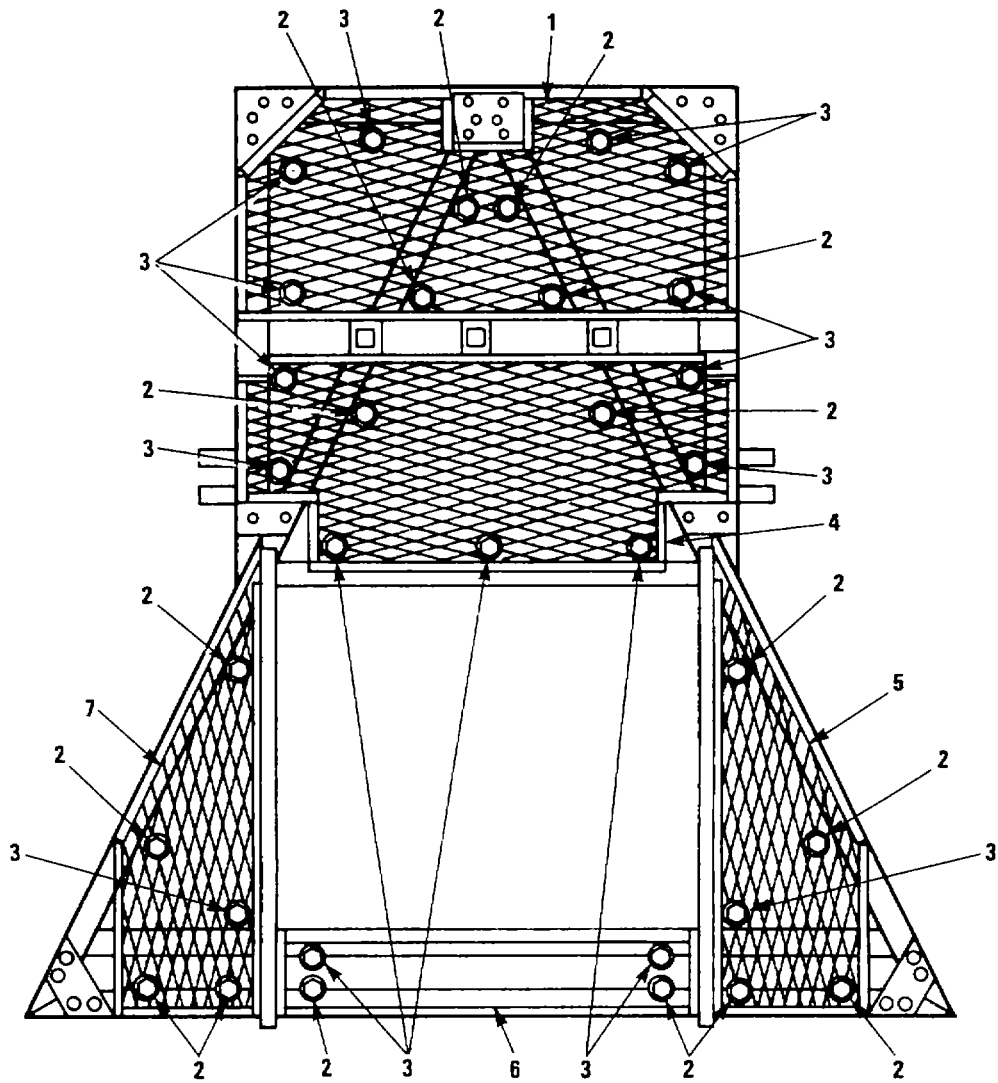

LEGEND

1. TOWER GRATING ASSEMBLY NO. 3
2. TYPE B GRATING CLAMP ASSEMBLY
3. TYPE A GRATING CLAMP ASSEMBLY
4. TOWER GRATING ASSEMBLY NO. 5
5. TOWER GRATING ASSEMBLY NO. 1
6. TOWER GRATING ASSEMBLY NO. 4
7. TOWER GRATING ASSEMBLY NO. 2
8. HEX HD BOLT, 3/8 - 16 X 1 3/4, GALV
9. GRATING CLAMP NO. 1
10. SPLIT LOCKWASHER, 3/8, GALV
11. HEX NUT, 3/8 - 16 UNC, GALV
12. FLAT WASHER, 3/4, GALV
13. FLAT WASHER, 3/8, GALV
14. GRATING CLAMP NO. 2

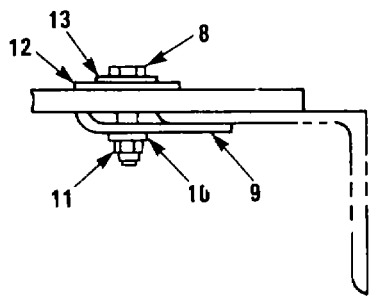

TYPE A GRATING CLAMP ASSEMBLY

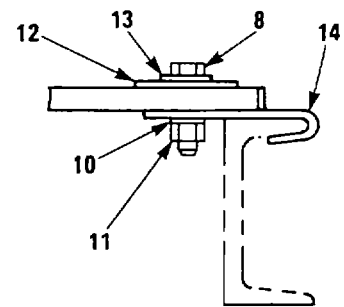

TYPE B GRATING CLAMP ASSEMBLY

Figure 5-10. Tower Grating Assemblies-Removal

(3) Detach two track angles (20) from long track brace (24) and two track angles (20) from channel support assembly No. 1 (26) by removing four bolts (11), nuts (4), lockwashers (5), and square beveled washers (19).

*m. Tower Adapter.*

(1) Remove tower parts necessary before lowering tower, and lower tower. Refer to paragraph 5-10h.

(2) Remove scaffold winch assembly (paragraph 5-10k) and horizontal tracks (paragraph 5-10l).

(3) Refer to figure 2-11. If any tackle block assemblies (12) are attached, detach them by removing nut (13), lockwasher (14), and square beveled washer (15). If vertical elevator tracks are attached, detach channel support assembly No. 1 (26) from top track assemblies Nos. 1 (22) and 2 (25) by removing eight bolts (21), nuts (7), and lockwashers (8).

(4) Refer to figure 2-10. Detach long track brace (29) from two channel support angles (20) by removing eight bolts (17), nuts (9), and lockwashers (10). Detach channel support angles (20) from channel support assemblies Nos. 2 (21) and 3 (30) by removing eight bolts (17), nuts (9), and lockwashers (10).

(5) Detach short track brace (31) from two channel support angles (20) by removing eight bolts (17), nuts (9), and lockwashers (10).

(6) Detach four scaffold reinforcing plates (19) from scaffold hinge assemblies Nos. 1 (32) and 2 (14) and channel support assemblies Nos. 2 (21) and 3 (30) by removing eight bolts (8), nuts (9), lockwashers (10), and square beveled washers (11).

(7) Detach four corner plates (12) from scaffold hinge assemblies Nos. 1 (32) and 2 (14) and scaffold support channels Nos. 1 (1) and 2 (7) by removing 16 bolts (8), nuts (9), lockwashers (10), and square beveled washers (11).

(8) Detach channel support angles (20) and scaffold hinge assemblies Nos. 1 (1) and 2 (7) from channel support assemblies Nos. 2 (21) and 3 (30) by removing eight bolts (8), nuts (9), and lockwashers (10).

(9) Detach scaffold support braces Nos. 1 (15) and 2 (16) from scaffold support channels Nos. 1 (1) and 2 (7) and from plate welded on tower leg A (18) by removing four bolts (17), nuts (9), and lockwashers (10).

(10) Unfasten scaffold support channels Nos. 1 (1) and 2 (7) from scaffold support plate (2) by removing two bolts (3), nuts (4), lockwashers (5), and square beveled washers (6). Detach scaffold support channels Nos. 1 (1) and 2 (7) from plates welded on channel support assemblies Nos. 2 (21) and 3 (30) by

removing two bolts (13), nuts (4), lockwashers (5), and square beveled washers (6).

(11) Detach scaffold support plate (2) from channel support assemblies Nos. 2 (21) and 3 (30) by removing remaining four bolts (3), nuts (4), lockwashers (5), and square beveled washers (6).

(12) Detach two channel tie plates (24) from channel support assemblies Nos. 1 (26), 2 (21), and 3 (30) by removing eight bolts (13), nuts (4), lockwashers (5), and square beveled washers (6).

(13) Detach channel support assemblies Nos. 1 (26), 2 (21), and 3 (30) from tower legs A (18), B (28), and C (22) by removing six bolts (13), nuts (4), lockwashers (5), and square beveled washers (6) and six bolts (23), nuts (4), and lockwashers (5).

*n. Tower Section No. 4.* A 1-ton winch truck is needed, as well as a tower hoist. Refer to figure 5-11, unless otherwise indicated and take all applicable precautions.

(1) First, do the following:

(a) Remove all parts necessary before lowering tower, and lower tower. Refer to paragraph 5-10h.

(b) Remove elevator tracks (paragraphs 5-10f or 5-10i).

(c) Remove tower adapter (paragraph 5-10m).

(2) Attach erection cable (2, figure 5-9) and multiple-leg sling assembly (1, figure 5-9).

(a) Attach multiple-leg sling assembly to tower legs B and C at bottom of tower section No. 3 in the same manner as shown in figure 5-9.

(b) Attach one end of erection cable to snatch block and the other end of the cable to multiple-leg sling assembly.

(c) Engage tower hoist cable with snatch block and attach this cable to eye bolt in hoist frame assembly. (See figure 2-5.)

(3) With tower hoist (3, figure 5-9) and gin pole (5, figure 5-9), elevate tower slightly. Make sure that erection cable rides in cable slot at top of gin pole before starting to raise tower. Remove supporting blocks and place them under legs B and C of tower section No. 3, 1 foot 6 inches from top of leg assemblies. Do not lower tower yet.

(4) Attach cable from winch truck to leg A of tower section No. 4.

(5) Detach tower section No. 4 by removing nine bolts (12), nuts (8), and lockwashers (9).

(6) With winch truck, lower tower section No. 4 to ground. With tower hoist, lower rest of tower onto supporting blocks.

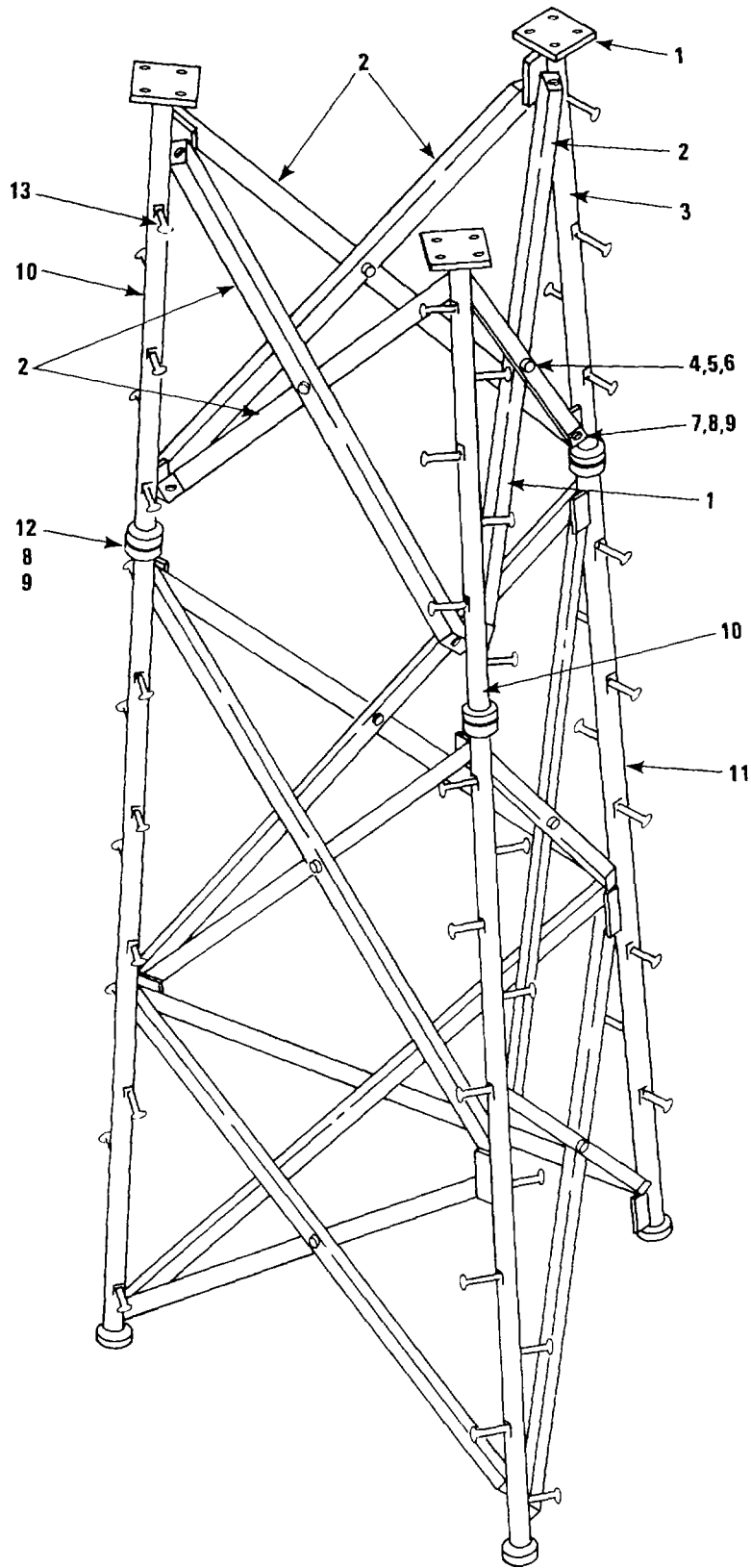

**LEGEND**

1. TOWER SECTION NO. 4
2. TOWER BRACE NO. 7
3. FRONT TOP TOWER LEG ASSEMBLY
4. HEX HD BOLT, 1/2 - 13 UNC X 7, GALV
5. HEX NUT, 1/2 - 13 UNC, GALV
6. SPLIT LOCKWASHER, 1/2, GALV
7. HEX HD BOLT, 3/4 - 10 UNC X 1 3/4, GALV
8. HEX NUT, 3/4 - 10 UNC, GALV
9. HEAVY SPLIT LOCKWASHER, 3/4, GALV
10. TOP TOWER LEG ASSEMBLY
11. TOWER SECTION NO. 3
12. HEX HD BOLT, 3/4 - 10 UNC X 3 1/4, GALV
13. TOWER STEP

**Figure 5-11. Tower Section No. 4**

*o. Tower Sections Nos. 2 and 3.* A 1-ton winch truck and a tower hoist are needed. Refer to figure 5-12. Take all applicable precautions.

(1) First, do the following:

(a) Remove all parts necessary before lowering tower, and lower tower. Refer to paragraph 5-10h.

(b) Remove elevator tracks (paragraph 5-10f or 5-10i).

(c) Remove tower adapter (paragraph 5-10m).

(d) Remove tower section No. 4 (paragraph 5-10n).

(e) For tower section No. 2, remove tower section No. 3.

(2) Connect multiple-leg sling assembly, erection cable, and tower hoist as described in paragraph 5-10n, step (2), except connect multiple-leg sling assembly to tower section No. 2 for removing tower section No. 3, or to tower section No. 1 for removing tower section No. 2.

(3) Raise tower slightly by using erection hoist and gin pole. Be sure that erection cable rides in cable slot at top of gin pole before starting to raise tower. Move supporting blocks to remaining tower section adjacent to the one being removed. Place them under legs B and C, 1 foot 6 inches from top of leg assemblies. Do not lower tower yet.

(4) Remove nine bolts (10), nuts (7), and lockwashers (8) that connect tower section to be removed from the adjacent one.

(5) With winch truck, lower detached tower section to ground. With tower hoist lower rest of tower onto supporting blocks.

*p. Tower Section No. 1.* Refer to figure 5-13. A 1-ton winch truck is needed.

(1) Remove all parts necessary before lowering tower, and lower tower. Refer to paragraph 5-10h.

(2) Remove all tower parts necessary before removing tower sections Nos. 2, 3, and 4; then remove these tower sections. Refer to paragraphs 5-10n and 5-10o.

(3) Attach cable from winch truck to tower section.

(4) With winch truck, raise tower section slightly. Remove supporting blocks.

(5) Detach tower legs B and C (5) from tower pivots Nos. 1 and 2 (1) by removing three bolts (2), nuts (3), and lockwashers (4) for each leg.

(6) With winch truck, lower tower section to ground.

*q. Tower Grounding Kit.* Refer to figure 5-13.

(1) At each tower leg pier, detach one nut (10), lockwasher (11), flat washer (15), and ground wire assembly (14).

(2) If tower pivot base assemblies and tower support are not to be removed, replace nuts (10) and lockwashers (11).

*r. Tower Support.* Refer to figure 2-6.

(1) If tower sections have not been removed, lower tower (paragraph 5-1 Oh).

(2) Remove gin pole. Refer to paragraph 2-15d.

(3) Detach tower support from tower leg A by removing three bolts (11), nuts (10), and lockwashers (9).

*s. Tower Pivots.* Refer to figure 5-13.

(1) Remove tower sections. Refer to paragraphs 5-10n through 5-10p.

(2) Detach tower pivots Nos. 1 and 2 (1) from tower pivot base assemblies (9) by removing three bolts (2), nuts (3), and lockwashers (4) for each pivot.

(3) Detach two tower pivot base assemblies from piers by removing for each assembly eight nuts (10) and lockwashers (11). Also remove one flat washer (15) and ground wire assembly (14) for each tower pivot base assembly.

*t. Tower Hoist.* Refer to figure 2-5.

(1) Disconnect power.

(2) Detach tower hoist from hoist frame assembly (13) by removing six nuts (10) and lockwashers (11) from winch bolts (9). Lift hoist off winch frame.

(3) Lift hoist frame assembly (13) off winch pad (12).

(4) Remove eye bolt (6), two nuts (7), and one lockwasher (8) from hoist frame assembly.

## 5-11. DISASSEMBLY.

*a. Tower Sections Nos. 1, 2, and 3.* Refer to figure 5-12. A 1-ton winch truck is needed.

### **WARNING**

**When working on structural tower, use safety climbing belts and hold tools and materials in proper containers. Pass tools and materials by using appropriate containers or ropes.**

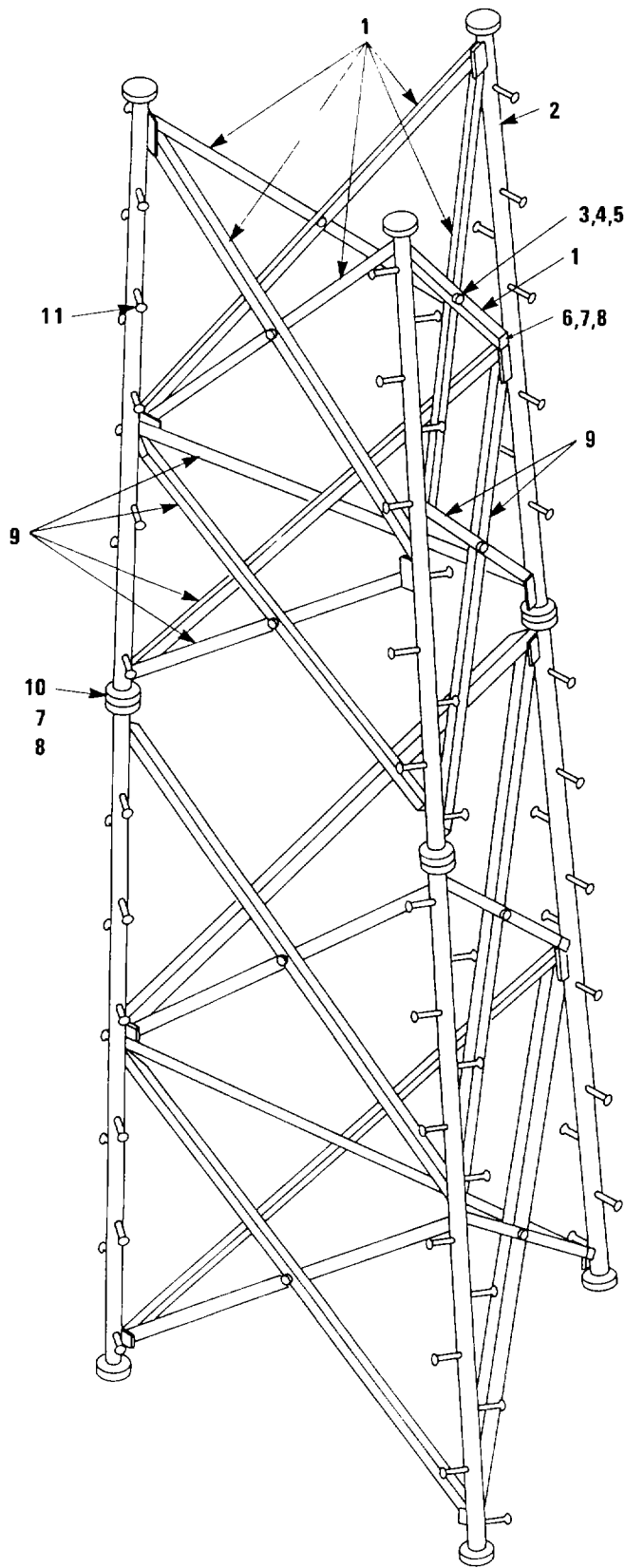

**LEGEND**

- 1. TOWER BRACE –  
NO. 6 FOR TOWER SECTION NO. 3  
NO. 4 FOR TOWER SECTION NO. 2
- 2. TOWER LEG ASSEMBLY
- 3. HEX HD BOLT, 1/2 - 13 UNC × 7, GALV
- 4. HEX NUT, 1/2 - 13 UNC, GALV
- 5. SPLIT LOCKWASHER, 1/2, GALV
- 6. HEX HD BOLT, 3/4 - 10 UNC × 1 3/4, GALV
- 7. HEX NUT, 3/4 - 10 UNC, GALV
- 8. HEAVY SPLIT LOCKWASHER, 3/4, GALV
- 9. TOWER BRACE –  
NO. 5 FOR TOWER SECTION NO. 3  
NO. 3 FOR TOWER SECTION NO. 2
- 10. HEX HD BOLT, 3/4 - 10 UNC × 3 1/4, GALV
- 11. TOWER STEP

**Figure 5-12. Tower Section No. 2 or No. 3**



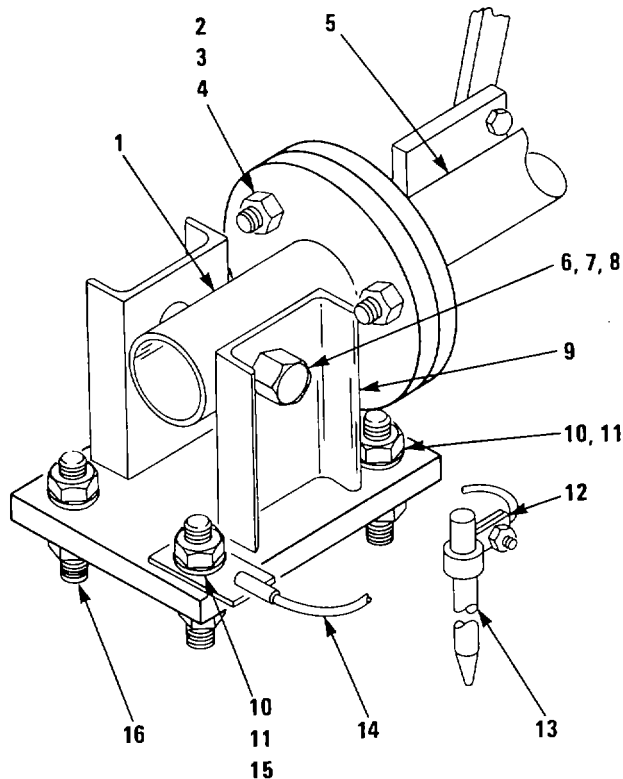

## LEGEND

1. TOWER PIVOT NO. 1 OR 2
2. HEX HD BOLT, 3/4 - 10 UNC X 3 1/4, GALV
3. HEAVY HEX NUT, 3/4 - 10 UNC, GALV
4. HEAVY SPLIT LOCKWASHER, 3/4, GALV
5. TOWER LEG ASSEMBLY
6. HEX HD BOLT, 1 1/2 - 6 UNC X 6, GALV
7. HEX NUT, 1 1/2 - 6 UNC, GALV
8. SPLIT LOCKWASHER, 1 1/2, GALV
9. TOWER PIVOT BASE ASSEMBLY
10. HEX NUT, 1 - 8 UNC, GALV
11. SPLIT LOCKWASHER, 1, GALV
12. GROUND WIRE CLAMP
13. GROUND ROD
14. GROUND WIRE ASSEMBLY
15. FLAT WASHER, 1, GALV
16. ANCHOR BOLT

Figure 5-13. Tower Pivot and Grounding Kit

(1) Remove tower section. Refer to paragraph 5-10o for tower sections Nos. 2 and 3 and to paragraph 5-10p for tower section No. 1.

(2) Attach cable from winch truck to tower leg A of tower section.

(3) With face A on ground, remove two bolts (3), nuts (4), and lockwashers (5) from crossover junctions of braces (1 and 9) between legs A and B. Detach these braces from tower legs by removing eight bolts (6), nuts (7), and lockwashers (8). Use ladder to reach bolts of face A.

(4) Repeat step (3) to remove braces between legs B and C and attaching hardware.

(5) Lower leg A to ground, with leg C serving as a pivot. Repeat step (3) to detach remaining braces and attaching hardware.

*b. Tower Section No. 4.* Refer to figure 5-11. A 1-ton winch truck is needed.

(1) Remove tower section No. 4. Refer to paragraph 5-10n.

(2) Attach cable from winch truck to top front tower leg assembly.

(3) With face A on the ground, remove bolt (4), nut (5), and lockwasher (6) from crossover junction of two tower braces No. 7 (2). Detach these braces from front top tower leg assembly (3) and one of top tower leg assemblies (10) by removing four bolts (7), nuts (8), and lockwashers (9). Use ladder to reach bolts on front top leg assembly.

(4) Repeat step (3) to remove tower braces No. 7 and attaching hardware for tower face on ground.

(5) With the leg on ground acting as a pivot, lower remaining tower face to ground.

(6) Repeat step (3) to remove remaining braces and attaching hardware.

*c. Elevator Tracks.* Refer to figure 5-8.

(1) Remove elevator tracks from tower. Refer to paragraph 5-10f or 5-10i. If the tracks are removed when tower is lowered (paragraph 5-10i), disassembly is complete. If tracks have been removed when tower is erect (paragraph 5-10f), proceed to next step.

(2) Detach two track assemblies (4) from track supports Nos. 7 (6), 8 (5), and 9 (3) by removing 12 bolts (21), nuts (19), and lockwashers (20).

(3) Likewise, detach two track assemblies (4) from track supports Nos. 4 (9), 5 (8), and 6 (7), and two track assemblies (4) from track supports Nos. 1 (11), 2 (10), and 3 (15).

**5-12. CLEANING.**

**WARNING**

**The fumes of trichloroethane are toxic. Provide thorough ventilation whenever used. DO NOT USE NEAR AN OPEN FLAME. Trichloroethane is not flammable, but exposure of the fumes to an open flame or hot metal forms highly toxic phosgene gas.**

- a. Remove dust and dirt from the equipment by using a lint-free cloth.
- b. Use a 1-inch bristle brush to remove dirt and dust from hard-to-reach areas.
- c. Remove grease with trichloroethane and wipe dry with a clean, dry, lint-free cloth.
- d. Remove caked-on dirt with a 1-inch bristle brush soaked with trichloroethane. Wipe dry with a clean, dry, lint-free cloth.

**5-13. INSPECTION.**

*a. Erected Tower.*

- (1) Check piers for settling. Measure their heights above ground and compare these measurements with previous measurements.
- (2) With spirit levels, check that tower is still level.
- (3) Check all metal parts and the gin pole for rust and corrosion.
- (4) Check all structural members for physical damage, including bending of braces.
- (5) Check all attaching hardware. Be sure that bolts, nuts, and screws are tight and that none is missing.

- (6) Check gin pole for damages.
- b. Tower Adapter.*
  - (1) Make the checks specified in paragraph 5-13a, steps (3), (4), and (5).
  - (2) Check scaffold winch assembly.
    - (a) Check that winch and pulley turn freely.
    - (b) Inspect winch line for kinks or other damage.
    - (c) Inspect chain shackle for damage.
- c. Tower Erection Kit.*
  - (1) Check all bolts, nuts, and screws for tightness. Check that none is missing.
  - (2) Check all metal parts for corrosion or other damage.
  - (3) Inspect erection cable, multiple-leg sling assembly, aircraft cable for hoist, and tag ropes for damage, including kinks in wire cables. Check that snatch block works smoothly. Inspect snatch block and eye bolt for damage.
- d. Antenna Elevator and Carriage.*
  - (1) Inspect all metal parts for corrosion or other damage.
  - (2) Check all attaching hardware for tightness. Check that there are no missing nuts, bolts, or screws.
  - (3) Check tracks for alignment.
  - (4) Check that all rollers work smoothly.
  - (5) Inspect rope guide assembly for damage.
  - (6) Inspect elevator erection sling and anchor shackle for damages.

**5-14. ASSEMBLY AND INSTALLATION.** Refer to paragraphs 2-12 through 2-17.

## CHAPTER 6

## FUNCTIONING OF EQUIPMENT

**6-1. GENERAL.** A functional explanation of the Antenna Tower TS-1A, describing the relationship of the equipment components to the end item and the function of the individual units, is provided in paragraph 6-2. For additional coverage on the AN/GSA-131(V)1 or the AN/GSA-131(V)2 antenna group, refer to TM 32-5985-201-15.

**6-2. FUNCTIONAL EXPLANATION.**

a. Antenna Tower TS-1A is a self-supporting tower designed to support either the AN/GSA-131(V)1 or AN/GSA-131(V)2 antenna group. The antenna tower is equipped with an electrically powered elevator that transports the antenna to or from the top of the antenna tower during antenna installation or removal. It is also possible to attach a maintenance platform to the antenna tower to provide access to all parts of the antenna after it has been fully erected on the tower.

b. The elevator hoist assembly is an electrically operated, worm-gear reduction, chain-driven hoist with a capacity of 2000 pounds. The elevator hoist assembly is used to raise and lower the antenna elevator. A manually operated, two-position, momentary switch, the elevator hoist control controls the raising and lowering of the antenna elevator. This remote switch is located on one of the tower legs. When the UP button is pressed, the elevator is raised; when the DOWN button is pressed, the elevator is lowered. The brake in the elevator hoist assembly automatically holds the load when the buttons are not pressed.

c. The direction of the hoist drum rotation must be observed after the 230/460 V, three-phase, 60 Hz power is supplied to the elevator hoist control. The direction of rotation should correspond with the direction indicated by the control. If it is not, the direction can be reversed by interchanging any two of the three input power leads of the control (figure 6-1).

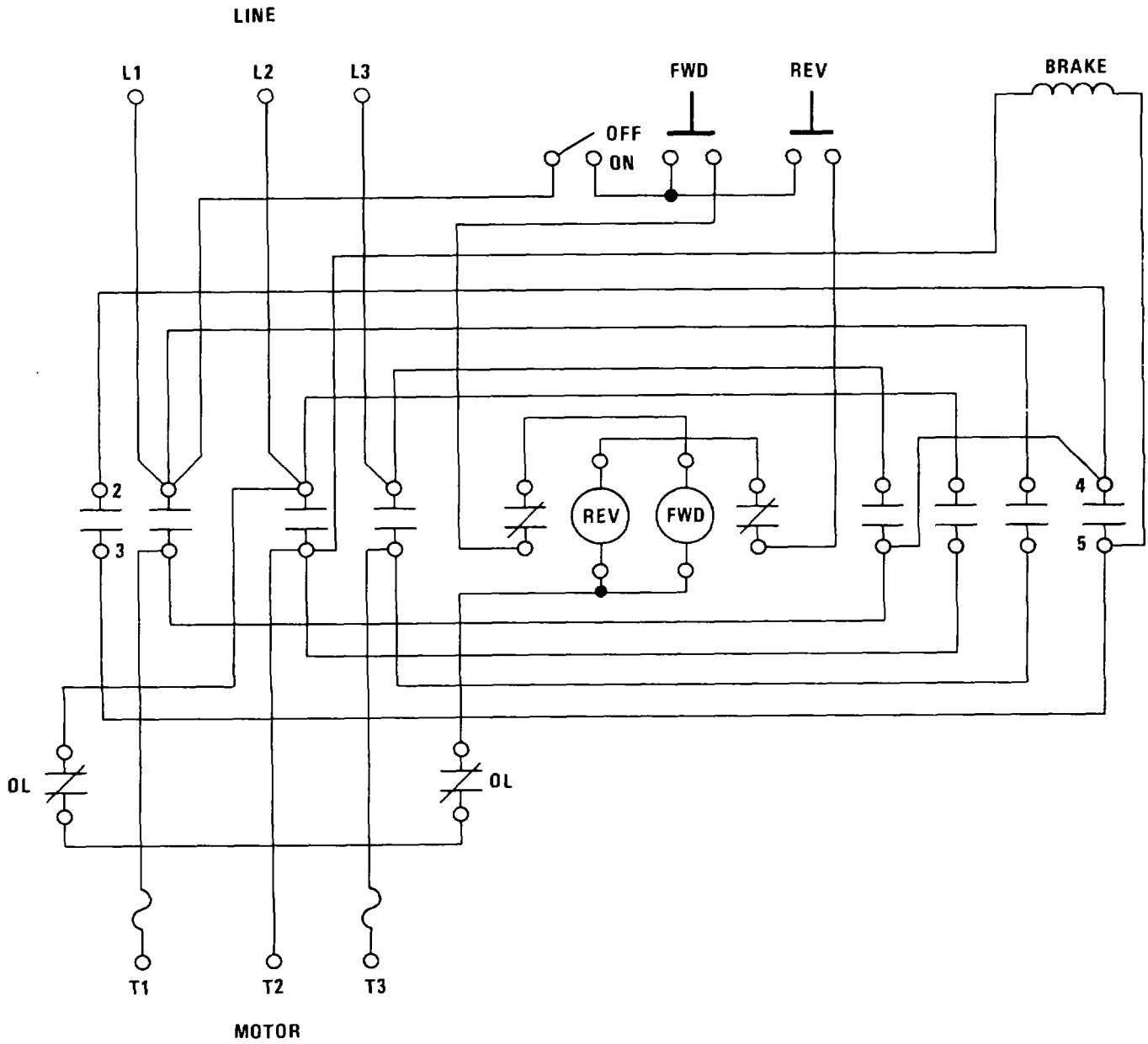

Figure 6-1. Elevator Hoist Control Schematic

## CHAPTER 7

## DIRECT SUPPORT MAINTENANCE INSTRUCTIONS

## Section I. GENERAL

**7-1. SCOPE.** Direct support maintenance for the Antenna Tower TS-1A consists of the maintenance functions authorized by the Maintenance Allocation

Chart, Appendix D, of this manual. Maintenance instructions in this chapter cover replacement of tower components.

## Section II. TOOLS AND EQUIPMENT

**7-2. TOOLS AND TEST EQUIPMENT.** The tools and the test equipment needed for direct support maintenance are listed in Appendix D, Maintenance Allocation Chart.

**7-3. TEST EQUIPMENT.** The AN/USM-223 multimeter is used for voltage and resistance measurements in the circuits of the tower and elevator hoists.

## Section III. TROUBLESHOOTING

**7-4. GENERAL.** Refer to table 5-5 for troubleshooting procedures.

## Section IV. MAINTENANCE OF ANTENNA TOWER TS-1A

**7-5. REMOVAL OF COMPONENTS.** See paragraph 5-10 for removal instructions for all components of the tower.

**7-6. DISASSEMBLY.**

*a. Safety Precautions.* Refer to paragraphs 2-11 and 5-10 for safety precautions.

*b. Scaffold Winch Assembly.* Refer to figure 7-1.

(1) Remove winch cable (6) from winch (11).

(2) Remove sheave (3) and two pulley spacers (2) from winch support (10) by removing bolt (1), nut (5), and lockwasher (4).

(3) Detach winch (11) from winch support (10) by removing two bolts (7), nuts (8), and lockwashers (9).

**WARNING**

**High voltage is used in operation of electric hoists. Death or injury may result from contact with high voltage connections. The 230/460-volt power for hoist motors and controls is lethal. Disconnect this power before servicing hoist motors or controls, or any hoist circuits.**

*c. Tower Hoist.* Refer to figure 7-2.

(1) Detach motor assembly (11 and 12) by removing four bolts (13), nuts (14), and lockwashers (15). Disengage motor sprocket (10) from chain (7).

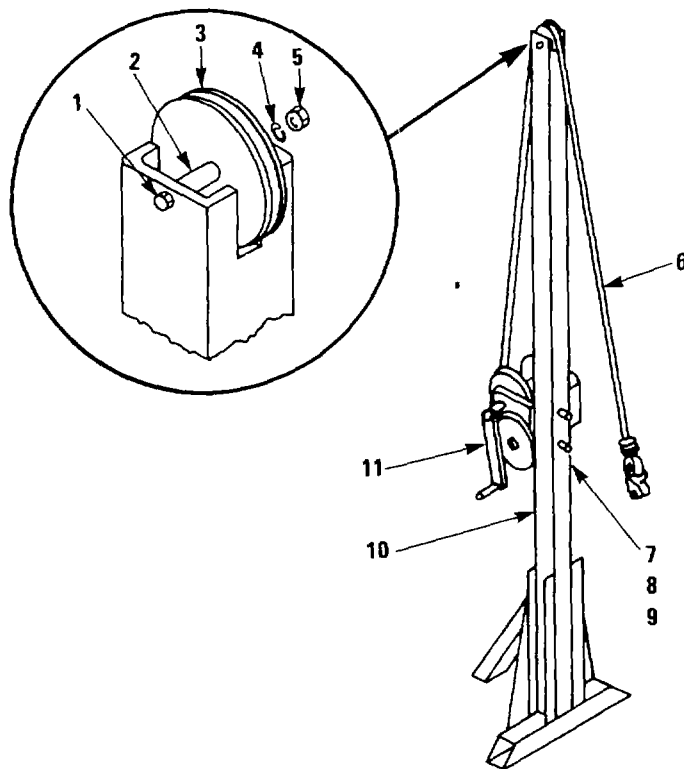

**LEGEND**

- 1. HEX HD BOLT, 5/8 - 11 UNC × 1 3/4, GALV
- 2. PULLEY SPACER
- 3. SHEAVE
- 4. SPLIT LOCKWASHER, 5/8
- 5. HEX NUT, 5/8 - 11 UNC, GALV
- 6. WINCH CABLE
- 7. HEX HD BOLT, 3/8 - 16 UNC × 3 3/4, GALV
- 8. HEX NUT, 3/8 - 16, GALV
- 9. SPLIT LOCKWASHER, 3/8, GALV
- 10. WINCH SUPPORT
- 11. WINCH

**Figure 7-1. Scaffold Winch Assembly**

(2) Detach chain guard (8) by removing four bolts (16), nuts (17), three machine screws (19), flatwashers (20), and nuts (21).

(3) Remove four chain tension bolts (9), two cap bolts (5), and six chain tension jam nuts (6).

(4) Locate and remove pin that connects both ends of chain (7), and remove chain.

(5) Reel out hoist cable (24) and remove it from drum (3).

(6) Detach two upright caps (4) by removing four bolts (1) and lockwashers (2).

(7) Detach two bearing assemblies (22) by removing two bearing bolt locks (23) and eight lockwashers (15) and hex nuts (14). Remove drum (3).

*d. Antenna Carriage Assembly.* Refer to figure 7-3.

(1) Detach four cam follower blocks (2) from antenna carriage assembly (1) by removing two bolts (4), nuts (5), and lockwashers (6) for each cam follower block (2).

(2) Remove two cam followers (3) from each cam follower block.

*e. Elevator Assembly.* Refer to figure 7-4.

(1) Detach four cam follower mounting blocks No. 1 (2) from elevator assembly (1) by removing two socket head cap screws (8 or 9) and lockwashers (7) for each mounting block.

(2) Detach four cam follower mount assemblies (4) from elevator assembly (1) by removing two socket head cap screws (8 or 9) and lockwashers (7) for each assembly.

(3) For each cam follower mounting block No. 1 (2), remove two cam followers (3).

(4) From each cam follower mount assembly (4), detach cam follower mounting block No. 2 (5) by removing four socket head cap screws (6) and lockwashers (7).

(5) Remove one cam follower (3) from each cam follower mount assembly (4) and from each cam follower mounting block No. 2 (5).

*f. Elevator Hoist.* The elevator hoist is not to be disassembled.

*g. Other Tower Components.* See paragraph 5-10 for disassembly instructions for tower parts not given in this chapter.

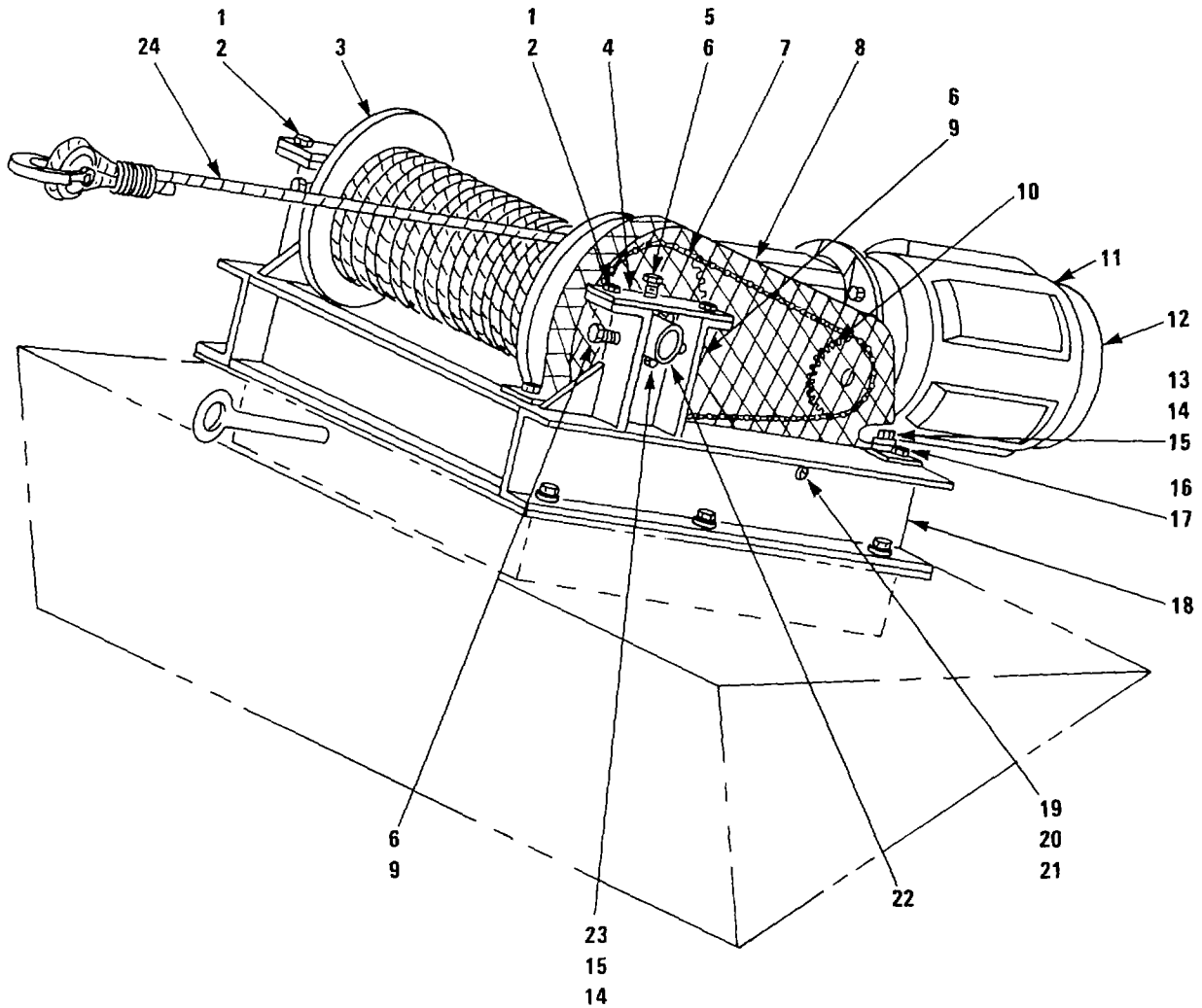

LEGEND

- |                                                           |                       |
|-----------------------------------------------------------|-----------------------|
| 1. CAP BOLT                                               | 13. CAP BOLT          |
| 2. LOCKWASHER                                             | 14. HEX NUT           |
| 3. DRUM                                                   | 15. LOCKWASHER        |
| 4. UPRIGHT CAP                                            | 16. CAP BOLT          |
| 5. CAP BOLT                                               | 17. SELF-LOCKING NUT  |
| 6. CHAIN TENSION JAM NUT                                  | 18. HOIST FRAME       |
| 7. CHAIN                                                  | 19. MACHINE SCREW     |
| 8. CHAIN GUARD                                            | 20. FLAT WASHER       |
| 9. CHAIN TENSION BOLT                                     | 21. HEX NUT           |
| 10. MOTOR SPROCKET, 2 1/8 BORE                            | 22. BEARING ASSEMBLY  |
| 11. MOTOR, 5 HP, 27 RPM, 3 PHASE,<br>60 HZ, 230/460 VOLTS | 23. BEARING BOLT LOCK |
| 12. BRAKE, 25 FT-LB                                       | 24. HOIST CABLE       |

Figure 7-2. Tower Hoist

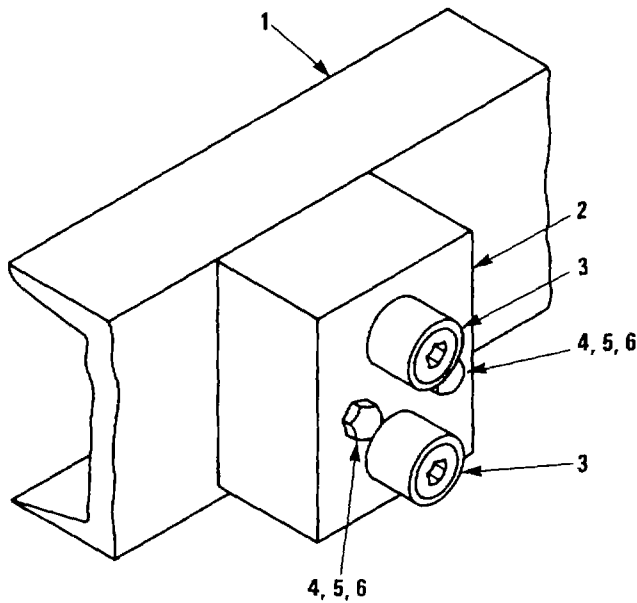

LEGEND

1. ANTENNA CARRIAGE ASSEMBLY
2. CAM FOLLOWER BLOCK
3. CAM FOLLOWER
4. HEX HD BOLT, 3/8 - 16 UNC X 2 1/2, SST
5. HEX NUT, 3/8 - 16 UNC, SST
6. SPLIT LOCKWASHER, 3/8, SST

Figure 7-3. Antenna Carriage Assembly

**7-7. REPAIR.** To repair a tower part, replace defective part with new one. See Section II, Appendix E, Repair Parts and Special Tools List, for part numbers. Requisition parts with an SMR code beginning with XB. Procure parts with an SMR code beginning with PA.

**7-8. ASSEMBLY.**

**CAUTION**

**When assembling scaffold winch assembly, make sure that crank axis is parallel to tower face A. The winch will then be able to move antenna carriage when it rides on horizontal tracks on tower adapter.**

a. *Scaffold Winch Assembly.* Refer to figure 7-1.

(1) Attach winch (11) to winch support (10). Secure with two bolts (7), nuts (8), and lockwashers (9).

(2) Insert sheave (3) and two pulley spacers (2) in top of winch support (10) and insert bolt (1)

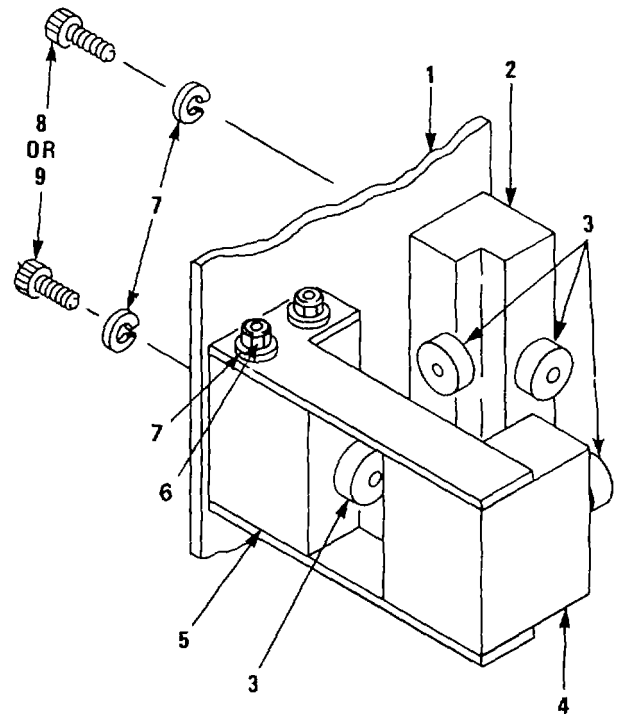

LEGEND

1. ELEVATOR ASSEMBLY
2. CAM FOLLOWER MOUNTING BLOCK NO. 1
3. CAM FOLLOWER
4. CAM FOLLOWER MOUNT ASSEMBLY
5. CAM FOLLOWER MOUNTING BLOCK NO. 2
6. SOCKET HD CAP SCREW, 1/2 - 13 UNC X 7/8, GALV
7. SPLIT LOCKWASHER, 1/2, GALV
8. SOCKET HD CAP SCREW, 1/2 - 13 UNC X 1 1/4, GALV
9. SOCKET HD CAP SCREW, 1/2 - 13 UNC X 1 3/4, GALV

Figure 7-4. Elevator Assembly Roller Assemblies

through sheave (3) and pulley spacers (2). Secure with lockwasher (4) and nut (5).

(3) Attach winch cable (6) to winch (11) and wind cable onto winch.

b. *Tower Hoist.* Refer to figure 7-2.

(1) Install drum (3) and two bearing assemblies (22). Secure with eight hex nuts (14) and lockwashers (15) and the two bearing bolt locks (23).

(2) Install the two upright caps (4). Secure with four cap bolts (1) and lockwashers (2).



(3) Attach hoist cable (24) to drum (3). For fastening, run end of the cable through flange to three-hole fastener. Loop the cable through the three holes so that cable overlaps itself in at least one position. Wind the hoist cable on drum.

(4) Loop chain (7) over drum sprocket wheel. Make certain that chain links (7) properly engage the teeth of sprocket (10). Connect both ends of chain by inserting pin.

(5) Install four chain tension bolts (9), two cap bolts (5), and six chain tension jam nuts (6).

(6) Install motor assembly (11). Secure with four cap bolts (13), nuts (14), and lockwashers (15). Make certain that the teeth of motor sprocket (10) properly engage the chain links.

(7) Adjust four chain tension bolts (9) and two cap bolts (5) for proper tautness of the drive chain.

(8) Apply a thin film of grease to the tooth faces of both drum and motor sprockets and to drive chain. (Refer to figure 5-2.)

(9) Install chain guard (8) and secure with four cap bolts (16) and nuts (17) and three machine screws (19), flatwashers (20), and hex nuts (21).

(10) Check motor and gear box for proper oil level. Refer to paragraph 5-5 and to tables 5-2 and 5-3.

(11) Make sure that the electrical power being used is 230/460-volt, three-phase, 60 Hz. Connect power and control. Check the direction of hoist drum and make certain that its direction of rotation corresponds to the direction of the control button that has been pressed. If the opposite direction results, reverse the direction by interchanging any two of the three power input leads.

c. *Antenna Carriage Assembly.* Refer to figure 7-3.

(1) Insert two cam followers (3) in each of four cam follower blocks (2).

(2) Attach four cam follower blocks (2) to antenna carriage assembly (1). Secure each cam follower block with two bolts (4), nuts (5), and lockwashers (6).

d. *Elevator Assembly.* Refer to figure 7-4.

(1) Insert one cam follower (3) in each of four cam follower mount assemblies (4) and in each of four cam follower mounting blocks No. 2 (5).

(2) Insert one cam follower (3) in each of four cam follower mounting blocks No. 1 (2).

(3) Insert one cam follower mounting block No. 2 (5) in each of four cam follower mount assemblies (4). Secure each with four socket head cap screws (6) and lockwashers (7).

(4) Attach four cam follower mount assemblies (4) to elevator assembly (1). Secure three with two socket head cap screws (8) and lockwashers (7) each. Secure one with two socket head cap screws (9) and lockwashers (7).

(5) Attach four cam follower mounting blocks No. 1 (2) to elevator assembly (1). Secure each of three with two socket head cap screws (8) and lockwashers (7). Secure one with two socket head cap screws (9) and lockwashers (7).

e. *Other Tower Components.* Refer to paragraphs 2-12 through 2-17.

**7-9 INSTALLATION.** Refer to paragraphs 2-12 through 2-17.

## Section V. DIRECT SUPPORT TESTING PROCEDURES

**7-10 GENERAL.** For testing of the Antenna Groups AN/GSA-131(V)1 or AN/GSA-131(V)2, refer to TM 32-

5985-201-15. For testing of the elevator hoist and antenna carriage assembly, refer to paragraph 2-17b.

7-5/(7-6 Blank)

**CHAPTER 8**

**GENERAL SUPPORT MAINTENANCE INSTRUCTIONS**

(There are no general support maintenance instructions for this equipment.)

**8-1/(8-2 Blank)**

**CHAPTER 9**

**MATERIEL USED IN CONJUNCTION WITH MAJOR ITEM**

(There is no materiel used in conjunction with the major item.)

**9-1/(9-2 Blank)**

## APPENDIX A

## REFERENCES

| <u>Reference</u>  | <u>Title</u>                                                                                                                                            |
|-------------------|---------------------------------------------------------------------------------------------------------------------------------------------------------|
| TM 32-5985-201-15 | Operator, Organizational, Direct Support, General Support, and Depot Maintenance Manual - Antenna System AN/GSA-131(V)1, AN/GSA-131(V)2, AN/GSA-131(V)3 |
| TM 38-750         | The Army Maintenance Management System (TAMMS)                                                                                                          |
| TM 43-0139        | Painting Instructions for Field Use                                                                                                                     |
| TM 740-90-1       | Administrative Storage of Equipment                                                                                                                     |
| TM 750-244-2      | Procedures for Destruction of Electronics Materiel to Prevent Enemy Use (Electronics Command)                                                           |
| AR 700-42         | Classification, Reclassification, Maintenance, Issuance and Reporting of Maintenance Training Aircraft                                                  |
| CTA 50-970        | Expendable Items (Except Medical, Class V, Repair Parts, and Heraldic Items)                                                                            |
| SF FORM 364       | Report of Discrepancy (ROD)                                                                                                                             |
| SB 11-573         | Painting and Preservation Supplies Available for Field Use for Electronics Command Equipment                                                            |
| SB 708-41/42      | Federal Supply Code for Manufacturers; United States and Canada. Name to Code and Code to Name (GSA-FSS H4-1/H4-2)                                      |
| SF 368            | Quality Deficiency Report                                                                                                                               |
| TB 43-0118        | Field Instructions for Painting and Preserving Electronics Command Equipment Including Camouflage Pattern Painting of Electrical Equipment Shelter      |

A-1/(A-2 Blank)

## APPENDIX B

## COMPONENTS OF END ITEM LIST

## Section I. INTRODUCTION

**B-1 SCOPE.** This appendix lists integral components of and Basic Issue Items (BII) for the Antenna Tower TS-IA to help you inventory items required for safe and efficient operation.

**B-2 GENERAL.** This Components of End Item List is divided into the following sections:

*a. Section II. Integral Components of the End Item.* These items, when assembled, comprise the tower and must accompany it whenever it is transferred or turned in. The illustrations will help you identify these items.

*b. Section III. Basic Issue Items (BII).* These are the minimum essential items required to place the tower in operation, to operate it, and to perform emergency repairs. Although shipped separately packed they must accompany the tower during operation and whenever it is transferred between accountable officers. The illustrations will assist you with hard-to-identify items. This manual is your authority to requisition replacement BII, based on TOE/MTOE authorization of the end item.

**B-3 EXPLANATION OF COLUMNS.**

*a. Illustration.* This column is divided as follows:

(1) *Figure Number.* Indicates the figure number of the illustration on which the item is shown.

(2) *Item Number.* The number used to identify item called out in the illustration.

*b. National Stock Number.* Indicates the National stock number assigned to the item and which will be used for requisitioning.

*c. Part Number.* Indicates the primary number used by the manufacturer, which controls the design and characteristics of the item by means of its engineering drawings, specifications, standards, and inspection requirements to identify an item or range of items.

*d. Description.* Indicates the Federal item name and, if required, a minimum description to identify the item.

*e. Location.* The physical location of each item listed is given in this column. The lists are designed to inventory all items in one area of the major item before moving on to an adjacent area.

*f. Usable on Code.* "USABLE ON" codes are included to help you identify which component items are used on the different models. Identification of the codes used in these lists are: none.

*g. Quantity Required (Qty Req'd).* This column lists the quantity of each item required for a complete major item.

*h. Quantity.* This column is left blank for use during an inventory. Under the Rcv'd column, list the quantity you actually receive on your major item. The Date columns are for your use when you inventory the major item at a later date; such as for shipment to another site.

Section II. INTEGRAL COMPONENTS OF END ITEM

| (1)<br>Illustration  |                    | (2)<br>National<br>Stock<br>Number | (3)<br>Part No. | (4)<br>Description                            | (5)<br>Location | (6)<br>Usable<br>On<br>Code | (7)<br>Qty<br>Reqd | (8)<br>Quantity |      |      |      |
|----------------------|--------------------|------------------------------------|-----------------|-----------------------------------------------|-----------------|-----------------------------|--------------------|-----------------|------|------|------|
| (a)<br>Figure<br>No. | (b)<br>Item<br>No. |                                    |                 |                                               |                 |                             |                    | Rev'd           | Date | Date | Date |
| E-1                  |                    |                                    | 0261-1-2000-1   | ANTENNA TOWER TS-1A                           |                 |                             | 1                  |                 |      |      |      |
| E-1                  | 24                 |                                    | 0261-1-3089-1   | TOWER PIVOT NO. 1                             | BOTTOM          |                             | 1                  |                 |      |      |      |
| E-1                  | 25                 |                                    | 0261-1-3089-2   | TOWER PIVOT NO. 2                             | BOTTOM          |                             | 1                  |                 |      |      |      |
| E-1                  | 12                 |                                    | 0261-14090-1    | TOWER SUPPORT                                 | BOTTOM          |                             | 1                  |                 |      |      |      |
| E-1                  | 8                  |                                    | 0261-1-2157-1   | TOWER GROUNDING KIT                           | BOTTOM          |                             | 1                  |                 |      |      |      |
| E-1                  | 3                  |                                    | 0261-1-2010-1   | TOWER SECTION KIT NO. 1                       | BOTTOM          |                             | 1                  |                 |      |      |      |
| E-1                  | 4                  |                                    | 0261-1-201 1-1  | TOWER SECTION KIT NO. 2                       | MIDDLE          |                             | 1                  |                 |      |      |      |
| E-1                  | 5                  |                                    | 0261-1-2012-1   | TOWER SECTION KIT NO. 3                       | MIDDLE          |                             | 1                  |                 |      |      |      |
| E-1                  | 6                  |                                    | 0261-1-2013-1   | TOWER SECTION KIT NO. 4                       | TOP             |                             | 1                  |                 |      |      |      |
| E-1                  | 1                  |                                    | 0261-1-2072-1   | TOWER ADAPTER INSTAL-<br>LATION               | TOP             |                             | 1                  |                 |      |      |      |
| E-1                  | 2                  | 5985-00-168-9392                   | 0261-1-2008-1   | TOWER ERECTION KIT                            |                 |                             | 1                  |                 |      |      |      |
| E-7                  | 4                  |                                    | 0261-1-3173-1   | TOWER HOIST ASSEMBLY                          | GROUND          |                             | 1                  |                 |      |      |      |
| E-1                  | 7                  | 5985-00-168-9394                   | 0261-1-2009-1   | ANTENNA ELEVATOR AND<br>CARRIAGE INSTALLATION | TOWER<br>SIDE   |                             | 1                  |                 |      |      |      |
| E-9                  | 24                 |                                    | 0261-1-4034-1   | ANTENNA CARRIAGE<br>ASSEMBLY                  | TOWER<br>SIDE   |                             | 1                  |                 |      |      |      |
| E-9                  | 25                 |                                    | 0261-14128-1    | ELEVATOR ASSEMBLY<br>SIDE                     | TOWER           |                             | 1                  |                 |      |      |      |
| E-9                  | 18                 |                                    | 0261-1-4133-1   | ELEVATOR HOIST<br>ASSEMBLY                    | BOTTOM          |                             | 1                  |                 |      |      |      |

Section III. BASIC ISSUE ITEMS

| (1)<br>Illustration  |                    | (2)                         | (3)                            | (4)                                    | (5)      | (6)                  | (7)         | (8)<br>Quantity |      |      |      |
|----------------------|--------------------|-----------------------------|--------------------------------|----------------------------------------|----------|----------------------|-------------|-----------------|------|------|------|
| (a)<br>Figure<br>No. | (b)<br>Item<br>No. | National<br>Stock<br>Number | Part No.                       | Description                            | Location | Usable<br>On<br>Code | Qty<br>Reqd | Rev'd           | Date | Date | Date |
|                      |                    |                             | 0261-1-2164-1<br>0261-1-3165-I | ROPE, TAG<br>SLING, ERECTION, ELEVATOR |          |                      | 2<br>1      |                 |      |      |      |

**APPENDIX C**

**ADDITIONAL AUTHORIZATION LIST**

(There are no additional items authorized for the support of the TS-1A Antenna Tower.)

**C-1/(C-2 Blank)**



**APPENDIX D  
MAINTENANCE ALLOCATION CHART**

**Section I. INTRODUCTION**

**D-1 GENERAL.**

a. This section provides a general explanation of all maintenance and repair functions authorized at various maintenance levels.

b. The Maintenance Allocation Chart (MAC) in Section II designates overall responsibility for the performance of maintenance functions on the identified end item or component. The implementation of the maintenance functions upon the end item or component will be consistent with the assigned maintenance functions.

c. Section III lists the special tools and test equipment required for each maintenance function as referenced from Section II.

d. Section IV contains supplemental instructions and explanatory notes for a particular maintenance function.

b. *Column 2, Component/Assembly.* Column 2 contains the names of components, assemblies, subassemblies, and modules for which maintenance is authorized.

c. *Column 3, Maintenance Function.* Column 3 lists the functions to be performed on the item listed in column 2. (For detailed explanation of these functions, see paragraph D-2.)

d. *Column 4, Maintenance Level.* Column 4 specifies, by the listing of a "work time" figure in the appropriate subcolumn(s), the lowest level of maintenance authorized to perform the function listed in column 3. This figure represents the active time required to perform the maintenance function at the indicated level of maintenance. If the number or complexity of the tasks within the listed maintenance function vary at different maintenance levels, appropriate "work time" figures will be shown for each level. The number of man-hours specified by the "work time" figure represents the average time required to restore an item (assembly, subassembly, component, module, end item, or system) to a serviceable condition under typical field operating conditions. This time includes preparation time, troubleshooting time, and quality assurance/quality control time in addition to the time required to perform the specific tasks identified for the maintenance functions authorized in the MAC. The symbol designations for the various maintenance levels are as follows:

O.....Organizational maintenance

e. *Column 5, Tools and Equipment.* Column 5 specifies, by code, those common tool sets (not individual tools) and special tools, Test, Measurement, and Diagnostic Equipment (TMDE), and support equipment required to perform the designated function.

f. *Column 6, Remarks.* This column shall, when applicable, contain a letter code, in alphabetical order, which shall be keyed to the remarks contained in Section IV.

**D-2 MAINTENANCE FUNCTIONS.**

a. *Inspect.* To determine the serviceability of an item by comparing its physical, mechanical and/or electrical characteristics with established standards through examination.

b. *Test.* To verify serviceability and detect incipient failure by measuring the mechanical or electrical characteristics of an item and comparing those characteristics with prescribed standards.

c. *Service.* Operations required periodically to keep an item in proper operating condition; i.e., to clean (decontaminate), to preserve, to drain, to paint, or to replenish fuel, lubricants, hydraulic fluids, or compressed air supplies.

d. *Install.* The act of emplacing, seating, or fixing into position an item, part, or module (component or assembly) in a manner to allow the proper functioning of an equipment or system.

e. *Replace.* The act of substituting a serviceable like type part, subassembly, or module for an unserviceable counterpart.

f. *Repair.* The application of maintenance services or other maintenance actions to restore serviceability to an item by correcting specific damage, fault, malfunction, or failure in a part, subassembly, module (component or assembly), and item, or system.

**D-3 EXPLANATION OF COLUMNS IN THE MAC, SECTION II.**

a. *Column 1, Group Number.* Column 1 lists group numbers, the purpose of which is to identify components, assemblies, subassemblies, and modules with the next higher assembly.

**D-4 EXPLANATION OF COLUMNS IN TOOL AND TEST EQUIPMENT REQUIREMENTS, SECTION III.**

a. *Column 1, Reference Code.* The tool and TMDE reference code correlates with a code used in the MAC, Section II, column 5.

b. *Column 2, Maintenance Level.* The lowest level of maintenance authorized to use the tool or test equipment.

c. *Column 3, Nomenclature.* Name or identification of the tool or test equipment.

d. *Column 4, National/NATO Stock Number.* The National Stock Number (NSN) of the tool or TMDE.

e. *Column 5, Tool Part Number.* The manufacturer's part number.

**D-5 EXPLANATION OF COLUMNS IN REMARKS, SECTION IV.** Not applicable.

Section II. MAINTENANCE ALLOCATION CHART

| (1)<br>Group Number | (2)<br>Component/<br>Assembly              | (3)<br>Maintenance Function                      | (4)<br>Maintenance Level |                                     |   |     |       | (5)<br>Tools and Equipment                           | (6)<br>Remarks |
|---------------------|--------------------------------------------|--------------------------------------------------|--------------------------|-------------------------------------|---|-----|-------|------------------------------------------------------|----------------|
|                     |                                            |                                                  | C                        | O                                   | F | H   | D     |                                                      |                |
| 00                  | ANTENNA TOWER TS-1A                        | Inspect<br>Service<br>Test<br>Install<br>Replace |                          | 59.0<br>27.0<br>1.5<br>50.0<br>25.0 |   |     |       | 1,2,3,4<br>5 thru 8<br><br>1,2,4 thru 11<br>5 thru 8 |                |
| 01                  | TOWER SECTION KIT NO. 1                    | Inspect<br>Service<br>Install<br><br>Replace     |                          | 5.0<br>3.0<br>34.0<br><br>25.0      |   |     |       | 4,7,10<br>1,2,4,7,8,10,<br>11<br>4,7,10              |                |
| 02                  | TOWER SECTION KIT NO. 2                    | Inspect<br>Service<br>Install<br><br>Replace     |                          | 5.0<br>3.0<br>37.0<br><br>24.0      |   |     |       | 4,7,10<br>1,2,4,7,8,10,<br>11<br>4,7,10              |                |
| 03                  | TOWER SECTION KIT NO. 3                    | Inspect<br>Service<br>Install<br><br>Replace     |                          | 5.0<br>3.0<br>40.0<br><br>23.0      |   |     |       | 4,7,10<br>1,2,4,7,8,10,<br>11<br>4,7,10              |                |
| 04                  | TOWER SECTION KIT NO. 4                    | Inspect<br>Service<br>Install<br><br>Replace     |                          | 4.0<br>3.0<br>43.0<br><br>22.0      |   |     |       | 4,7,10<br>1,2,4,7,8,10,<br>11<br>4,7,10              |                |
| 05                  | TOWER ADAPTER INSTALLATION                 | Inspect<br>Service<br>Install<br>Replace         |                          | 7.0<br>3.0<br>45.0<br>20.0          |   |     |       | 4,6<br>4,6<br>4,6                                    |                |
| 06                  | TOWER ERECTION KIT                         | Inspect<br>Service<br>Install<br>Replace         |                          | 5.0<br>3.0<br>0.5<br>1.0            |   |     |       | 3,4<br>4,6,7<br>4,6,7<br>4,6,7                       |                |
| 0601                | TOWER HOIST                                | Inspect<br>Service<br>Test<br>Install<br>Replace |                          | 6.0<br>3.0<br><br>1.0               |   | 2.0 | 4,6,7 | 3,4<br>4,6,7<br>0.5<br>4,6,7                         | 3,4            |
| 07                  | ANTENNA ELEVATOR AND CARRIAGE INSTALLATION | Inspect<br>Service<br>Install<br>Replace         |                          | 11.0<br>9.0<br>2.0<br>4.0           |   |     |       | 4<br>4 thru 7<br>4 thru 7<br>4 thru 7                |                |

Section II. MAINTENANCE ALLOCATION CHART

| (1)<br>Group Number | (2)<br>Component/<br>Assembly | (3)<br>Maintenance Function | (4)<br>Maintenance Level |     |   |   |   | (5)<br>Tools and Equipment | (6)<br>Remarks |
|---------------------|-------------------------------|-----------------------------|--------------------------|-----|---|---|---|----------------------------|----------------|
|                     |                               |                             | C                        | O   | F | H | D |                            |                |
| 0701                | ANTENNA CARRIAGE ASSEMBLY     | Inspect                     |                          | 2.0 |   |   |   |                            |                |
|                     |                               | Service                     |                          | 3.0 |   |   |   | 4,6,7                      |                |
|                     |                               | Install                     |                          | 0.5 |   |   |   | 4,6,7                      |                |
|                     |                               | Replace                     |                          | 1.0 |   |   |   | 4,6,7                      |                |
| 0702                | ELEVATOR ASSEMBLY             | Inspect                     |                          | 3.0 |   |   |   |                            |                |
|                     |                               | Service                     |                          | 3.0 |   |   |   | 4 thru 6                   |                |
|                     |                               | Install                     |                          | 1.0 |   |   |   | 4 thru 6                   |                |
|                     |                               | Replace                     |                          | 2.0 |   |   |   | 4 thru 6                   |                |
| 0703                | ELEVATOR HOIST                | Inspect                     |                          | 6.0 |   |   |   | 3,4                        |                |
|                     |                               | Service                     |                          | 3.0 |   |   |   | 4,6,7                      |                |
|                     |                               | Test                        |                          | 0.5 |   |   |   | 4,6,7                      |                |
|                     |                               | Install                     |                          | 1.0 |   |   |   | 4,6,7                      |                |
|                     |                               | Replace                     |                          | 2.0 |   |   |   | 4,6,7                      |                |

Section III. TOOL AND TEST EQUIPMENT REQUIREMENTS

| (1)<br>Reference<br>Code | (2)<br>Maintenance<br>Level | (3)<br>Nomenclature                       | (4)<br>National/NATO<br>Stock Number | (5)<br>Tool<br>Number |
|--------------------------|-----------------------------|-------------------------------------------|--------------------------------------|-----------------------|
| 1                        |                             | Spirit Level, 48-inch                     |                                      |                       |
| 2                        |                             | Spirit Level, 78-inch                     |                                      |                       |
| 3                        | O                           | Multimeter AN/USM-223                     | 6625-00-999-7465                     |                       |
| 4                        | O                           | Tool Kit, Installation, Antenna, TK-202/G | 5985-00-891-8485                     |                       |
| 5                        | O                           | Allen Wrench, 3/8-inch                    |                                      |                       |
| 6                        | O                           | Torque Wrench for 0-200 ft-lbs            |                                      |                       |
| 7                        | O                           | Torque Wrench for 0-600 ft-lbs            |                                      |                       |
| 8                        | O                           | Tripod, Fixed Leg                         |                                      |                       |
| 9                        | O                           | Measuring Tape, 100 feet                  |                                      |                       |
| 10                       | O                           | Winch Truck. 1-ton                        |                                      |                       |
| 11                       | OO                          | Transit Level                             |                                      |                       |

Section IV. REMAARKS

| Reference Code | Remarks          |
|----------------|------------------|
|                | (NOT APPLICABLE) |

APPENDIX E

REPAIR PARTS AND SPECIAL TOOLS LIST

Section I. INTRODUCTION

**E-1 SCOPE.** This appendix lists spares and repair parts; special tools; special Test, Measurement, and Diagnostic Equipment (TMDE), and other special support equipment required for performance of organizational, direct support, and general support maintenance of the Antenna Tower TS-1A. It authorizes the requisitioning and issue of spare and repair parts as indicated by the source and maintenance codes.

**E-2 GENERAL.** This Repair Parts and Special Tools List is divided into the following sections:

a. *Section II. Repair Parts List.* A list of spares and repair parts authorized for use in the performance of maintenance. The list also includes parts which must be removed for replacement of the authorized parts. Parts lists are composed of functional groups in numeric sequence, with the parts in each group listed in figure and item number sequence.

b. *Section III. Special Tools List.* Not applicable.

c. *Section IV. National Stock Number and Part Number Index.* A list, in National Item Identification Number (NIIN) sequence, of all National Stock Numbers (NSN) appearing in the listings, followed by a list in alphanumeric sequence of all part numbers appearing in the listings. National stock numbers and part numbers are cross-referenced to each illustration figure and item number appearance.

**E-3 EXPLANATION OF COLUMNS.**

a. *Illustration.* This column is divided as follows:

(1) *Figure Number.* Indicates the figure number of the illustration on which the item is shown.

(2) *Item Number.* The number used to identify item called out in the illustration.

b. *Source, Maintenance, and Recoverability (SMR) Codes.*

(1) *Source Code.* Source codes indicate the manner of acquiring support items for maintenance, repair, or overhaul of end items. Source codes are entered in the first and second positions of the uniform SMR code format as follows:

| <u>Code</u> | <u>Definition</u>                                         |
|-------------|-----------------------------------------------------------|
| PA          | Item procured and stocked for anticipated or known usage. |

AD Item to be assembled at depot maintenance level.

XB Item is not procured or stocked. If not available through salvage, requisition.

**NOTE: Cannibalization or salvage may be used as a source of supply for any items coded above except those coded XA and aircraft support items as restricted by AR 700-42.**

(2) *Maintenance Code.* Maintenance codes are assigned to indicate the levels of maintenance authorized to USE and REPAIR support items. The maintenance codes are entered in the third and fourth positions of the uniform SMR code format as follows:

(a) The maintenance code entered in the third position will indicate the lowest maintenance level authorized to remove, replace, and use the support item. The maintenance code entered in the third position will indicate one of the following levels of maintenance:

| <u>Code</u> | <u>Application/Explanation</u>                                       |
|-------------|----------------------------------------------------------------------|
| O           | Support item is removed, replaced, used at the organizational level. |

(b) The maintenance code entered in the fourth position indicates whether the item is to be repaired and identifies the lowest maintenance level with the capability to perform complete repair; i.e., all authorized maintenance functions. This position will contain one of the following maintenance codes:

| <u>Code</u> | <u>Application/Explanation</u>                                                                           |
|-------------|----------------------------------------------------------------------------------------------------------|
| F           | The lowest maintenance level capable of complete repair of the support item is the direct support level. |
| D           | The lowest maintenance level capable of complete repair of the support item is the depot level.          |
| Z           | Nonreparable. No repair is authorized.                                                                   |

(3) *Recoverability Code.* Recoverability codes are assigned to support items to indicate the disposition action

on unserviceable items. The recoverability code is entered in the fifth position of the uniform SMR code format as follows:

| Recoverability Code | Definition                                                                                                                              |
|---------------------|-----------------------------------------------------------------------------------------------------------------------------------------|
| Z                   | Nonreparable item. When unserviceable, condemn and dispose at the level indicated in position 3.                                        |
| F                   | Reparable item. When uneconomically reparable, condemn and dispose at the direct support level.                                         |
| D                   | Reparable item. When beyond lower level repair capability, return to depot. Condemnation and disposal not authorized below depot level. |

c. *National Stock Number (NSN)*. Indicates the NSN assigned to the item and which will be used for requisitioning.

d. *Part Number*. Indicates the primary number used by the manufacturer (individual, company, firm, corporation, or Government activity), which controls the design and characteristics of the item by means of its engineering drawings, specifications, standards, and inspection requirements to identify an item or range of items.

**NOTE: When a stock numbered item is requisitioned, the item received may have a different part number than the part being replaced.**

e. *Federal Supply Code for Manufacturer (FSCM)*. The FSCM is a 5-digit numeric code listed in SB 708-41/42 which is used to identify the manufacturer, distributor, or Government agency, etc.

f. *Description*. Indicates the Federal item name and, if required, a minimum description to identify the item.

g. *Unit of Measure (U/M)*. Indicates the standard of the basic quantity of the listed item as used in performing the actual maintenance function. This measure is expressed by a two-character alphabetical abbreviation (e.g., ea, in, pr, etc.). When the U/M differs from the unit of issue, the lowest unit of issue that will satisfy the required U/M will be requisitioned.

h. *Quantity Incorporated in Unit*. Indicates the quantity of the item used in the breakout shown on the illustration figure, which is prepared for a functional group, subfunctional group, or an assembly. A "V" appearing in this column in lieu of a quantity indicates that no specific quantity is applicable (e.g., shims, spacers, etc.).

**E-4 SPECIAL INFORMATION.** Not applicable.

**E-5 HOW TO LOCATE REPAIR PARTS.**

a. *When National Stock Number or Part Number is unknown.'*

(1) *First*. Using the table of contents, determine the functional group or subgroup within which the item belongs. This is necessary since illustrations are prepared for functional groups or subgroups, and listings are divided into the same groups.

(2) *Second*. Find the illustration covering the functional group or subgroup to which the item belongs.

(3) *Third*. Identify the item on the illustration and note the illustration figure and item number of the item.

(4) *Fourth*. Using the Repair Parts Listing, find the figure and item number notes on the illustration.

b. *When National Stock Number or Part Number is known:*

(1) *First*. Using the Index of National Stock Numbers and Part Numbers, find the pertinent NSN or part number. This index is in NIIN sequence, followed by a list of part numbers in alphanumeric sequence, cross-referenced to the illustration figure number and item number.

(2) *Second*. After finding the figure and item number, locate the figure and item number in the repair parts list.

**E-6 ABBREVIATIONS.** (Examples)

| Abbreviations | Explanation           |
|---------------|-----------------------|
| galv          | galvanized steel      |
| sst           | stainless steel       |
| UNC           | unified coarse thread |



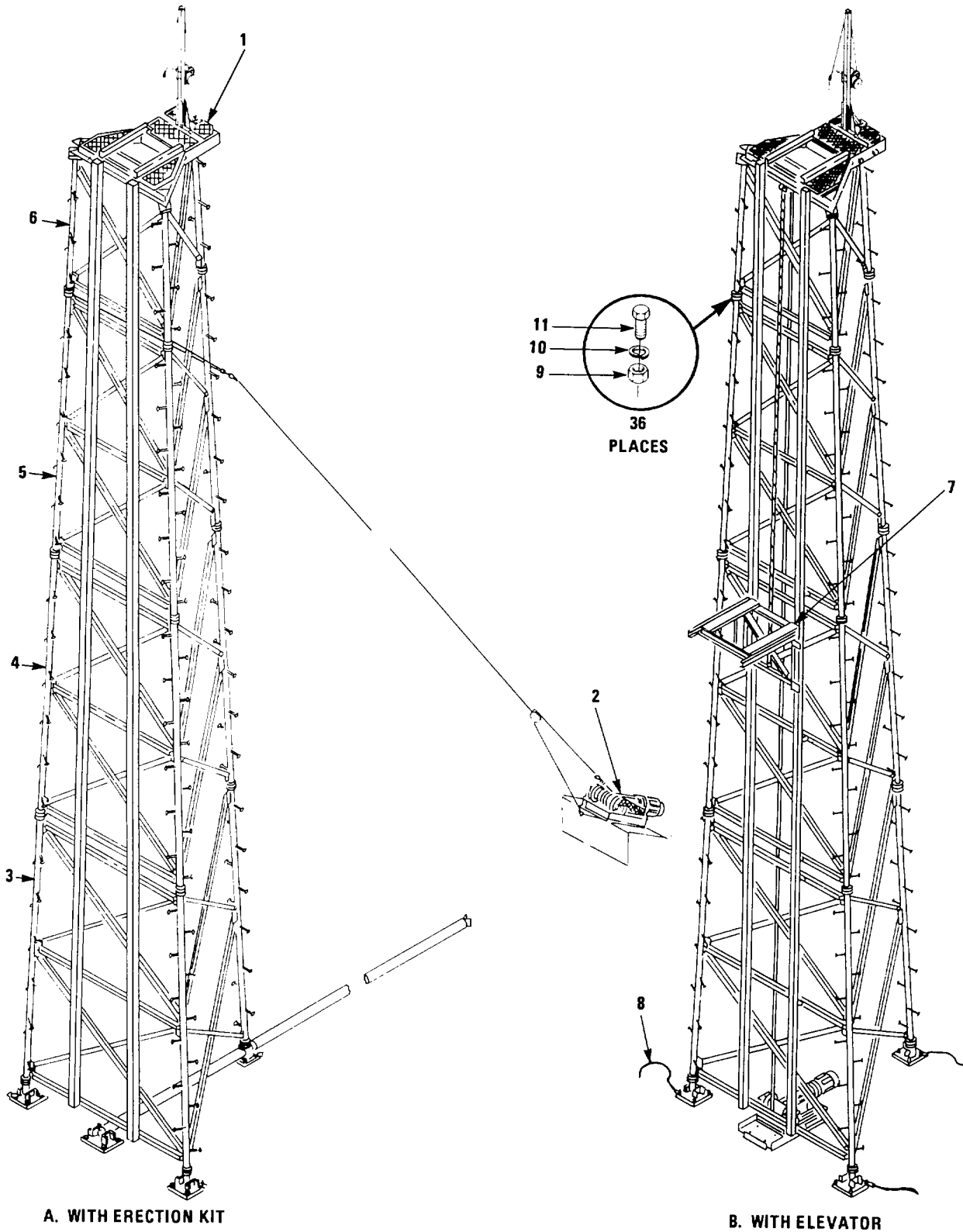

A. WITH ERECTION KIT

B. WITH ELEVATOR

Figure E-1. Antenna Tower TS-IA (Sheet 1 of 3)

(E-3 Blank)/E-4

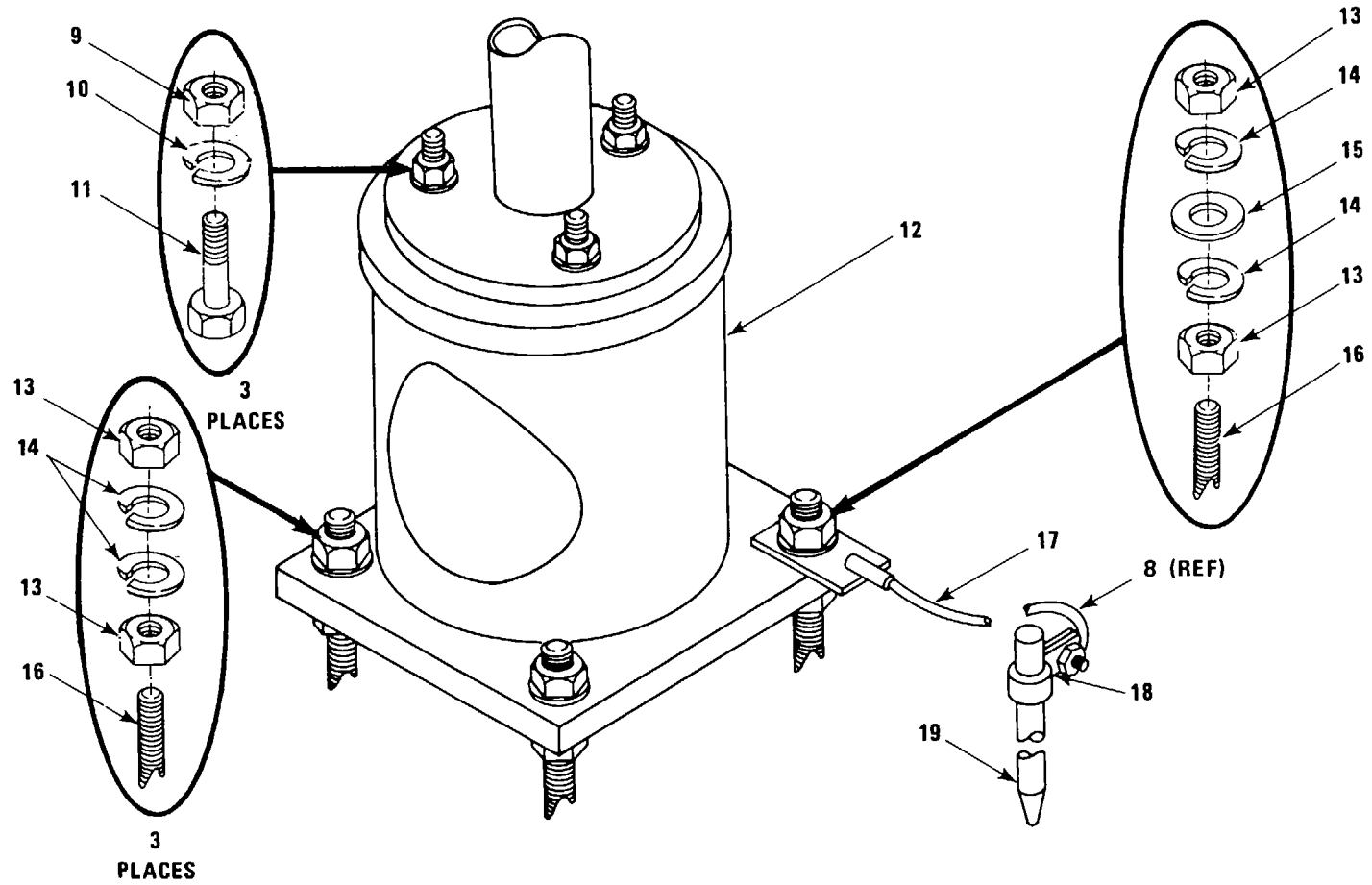

Figure E-1. Antenna Tower TS-1A (Sheet 2 of 3)

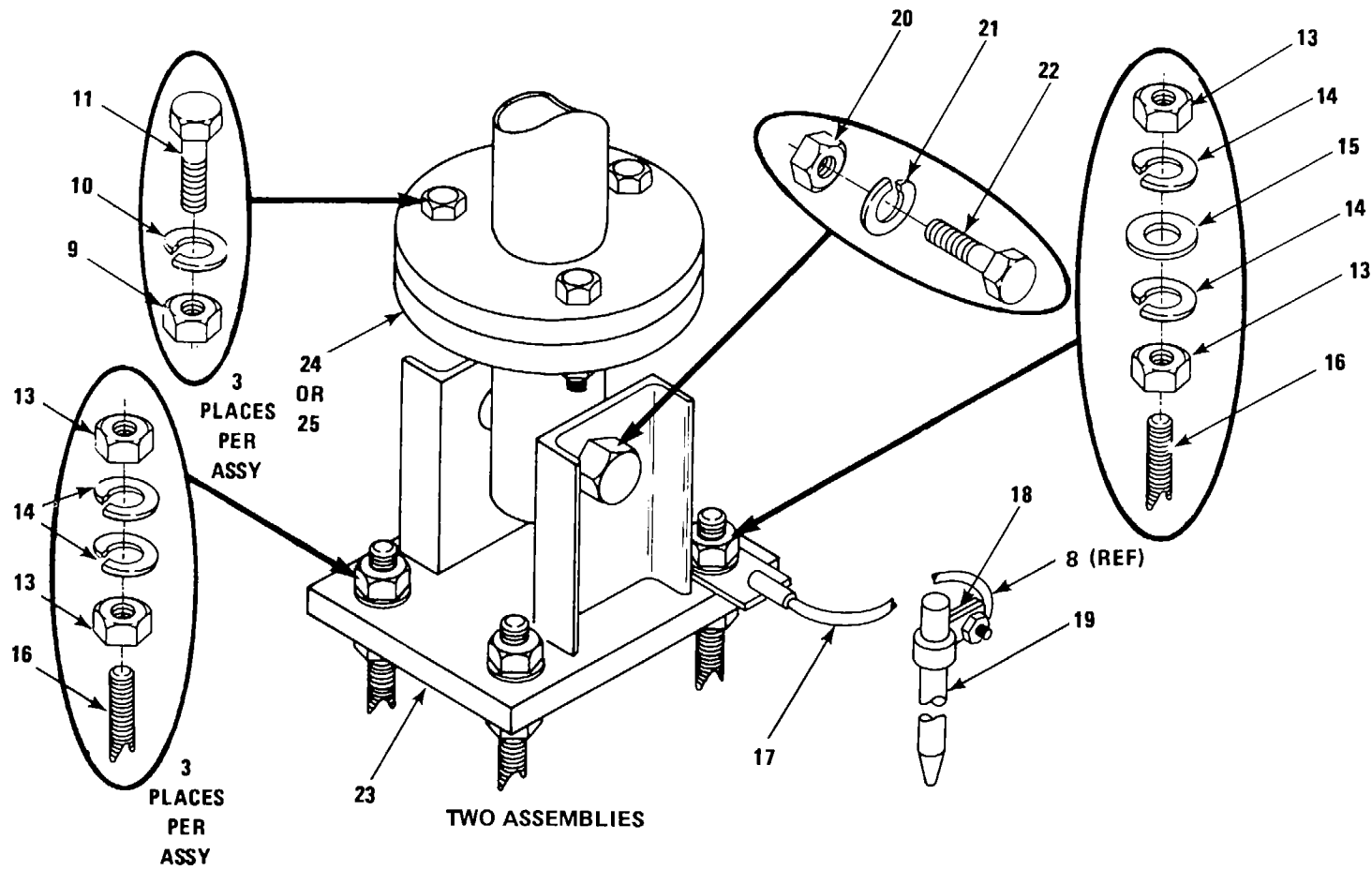

Figure E-1. Antenna Tower TS-1A (Sheet 3 of 3)

Section II. REPAIR PARTS LIST

| (1)<br>ILLUSTRATION |                    | (2)         | (3)                         | (4)            | (5)   | (6)<br>DESCRIPTION                                             | (7) | (8)                      |
|---------------------|--------------------|-------------|-----------------------------|----------------|-------|----------------------------------------------------------------|-----|--------------------------|
| (a)<br>FIG<br>NO.   | (b)<br>ITEM<br>NO. | SMR<br>CODE | NATIONAL<br>STOCK<br>NUMBER | PART<br>NUMBER | FSCM  | UOC                                                            | U/M | QTY<br>INC<br>IN<br>UNIT |
| E-1                 | 1                  | XBOFD       |                             | 0261-1-2072-1  | 15942 | GROUP: 00 ANTENNA TOWER<br>TS-1A<br>TOWER ADAPTER INSTALLATION | EA  |                          |
| E-1                 | 2                  | ADOFD       | 5985-00-168-9392            | 0261-1-2008,1  | 15942 | TOWER ERECTION KIT                                             | EA  |                          |
| E-1                 | 3                  | ADOFD       |                             | 0261-1-2010-1  | 15942 | TOWER SECTION KIT NO. 1                                        | EA  | 1                        |
| E-1                 | 4                  | ADOFD       |                             | 0261-1-2011-1  | 15942 | TOWER SECTION KIT NO. 2                                        | EA  | 1                        |
| E-1                 | 5                  | ADOFD       |                             | 0261-1-2012-1  | 15942 | TOWER SECTION KIT NO. 3                                        | EA  | 1                        |
| E-1                 | 6                  | ADOFD       |                             | 0261-1-2013-1  | 15942 | TOWER SECTION KIT NO. 4                                        | EA  | 1                        |
| E-1                 | 7                  | ADOFD       | 5985-00-168-9394            | 0261-1-2009-1  | 15942 | ANTENNA ELEVATOR AND<br>CARRIAGE INSTALLATION                  | EA  | 1                        |
| E-1                 | 8                  | XBOZZ       |                             | 0261-1-2157-1  | 15942 | TOWER GROUNDING KIT                                            | EA  | 1                        |
| E-1                 | 9                  | PAOZZ       | 5310-00-567-5212            | 2100-0878-001  | 15942 | NUT, HEAVY HEX, 3/4-10 UNC,<br>GALV                            | EA  | 36                       |
| E-1                 | 10                 | XBOZZ       |                             | 2300-0317      | 15942 | WASHER, HEAVY-SPLIT LOCK,<br>314, GALV                         | EA  | 36                       |
| E-1                 | 11                 | XBOZZ       |                             | 2076-4295      | 15942 | BOLT, HEX HD, 3/4-10 UNC X<br>3 1/4, GALV                      | EA  | 36                       |
| E-1                 | 12                 | XBOZZ       |                             | 0261-1-4090-1  | 15942 | SUPPORT, TOWER                                                 | EA  | 1                        |
| E-1                 | 13                 | PAOZZ       | 5310-00-401-1988            | 2100-0137      | 15942 | NUT, HEX, 1-8 UNC, GALV                                        | EA  | 24                       |
| E-1                 | 14                 | XBOZZ       |                             | 2300-0163      | 15942 | WASHER, SPLIT LOCK, 1,GALV                                     | EA  | 24                       |
| E-1                 | 15                 | XBOZZ       |                             | 2310-0618      | 15942 | WASHER, FLAT, 1, GALV                                          | EA  | 3                        |
| E-1                 | 16                 | XBOZZ       |                             | 0261-1-3094-1  | 15942 | BOLT, ANCHOR                                                   | EA  | 12                       |
| E-1                 | 17                 | XBOZZ       |                             | 0261-1-3159-1  | 15942 | WIRE ASSY, GROUND                                              | EA  | 3                        |
| E-1                 | 18                 | XBOZZ       |                             | 8900-0249      | 15942 | CLAMP, GROUND WIRE                                             | EA  | 3                        |
| E-1                 | 19                 | XBOZZ       |                             | 8900-0291      | 15942 | GROUND ROD                                                     | EA  | 3                        |
| E-1                 | 20                 | PAOZZ       | 5310-00-401-1989            | 2100-0149      | 15942 | NUT, HEX, 1 1/2-6 UNC, GALV                                    | EA  | 2                        |
| E-1                 | 21                 | XBOZZ       |                             | 2310-0612      | 15942 | WASHER, SPLIT LOCK 1 1/2,<br>GALV                              | EA  | 1                        |
| E-1                 | 22                 | XBOZZ       |                             | 2077-9245      | 15942 | BOLT, HEX HD, 1 1/2-6 UNC X<br>6, GALV                         | EA  | 2                        |
| E-1                 | 23                 | XBOFF       |                             | 0261-1-4088-1  | 15942 | BASE ASSY, PIOT, TOWER                                         | EA  | 2                        |
| E-1                 | 24                 | XBOZZ       |                             | 0261-1-3089-1  | 15942 | PIVOT, TOWER, NO. 1                                            | EA  | 1                        |
| E-1                 | 25                 | XBOZZ       |                             | 0261-1-3089-2  | 15942 | PIVOT, TOWER, NO. 2                                            | EA  | 1                        |

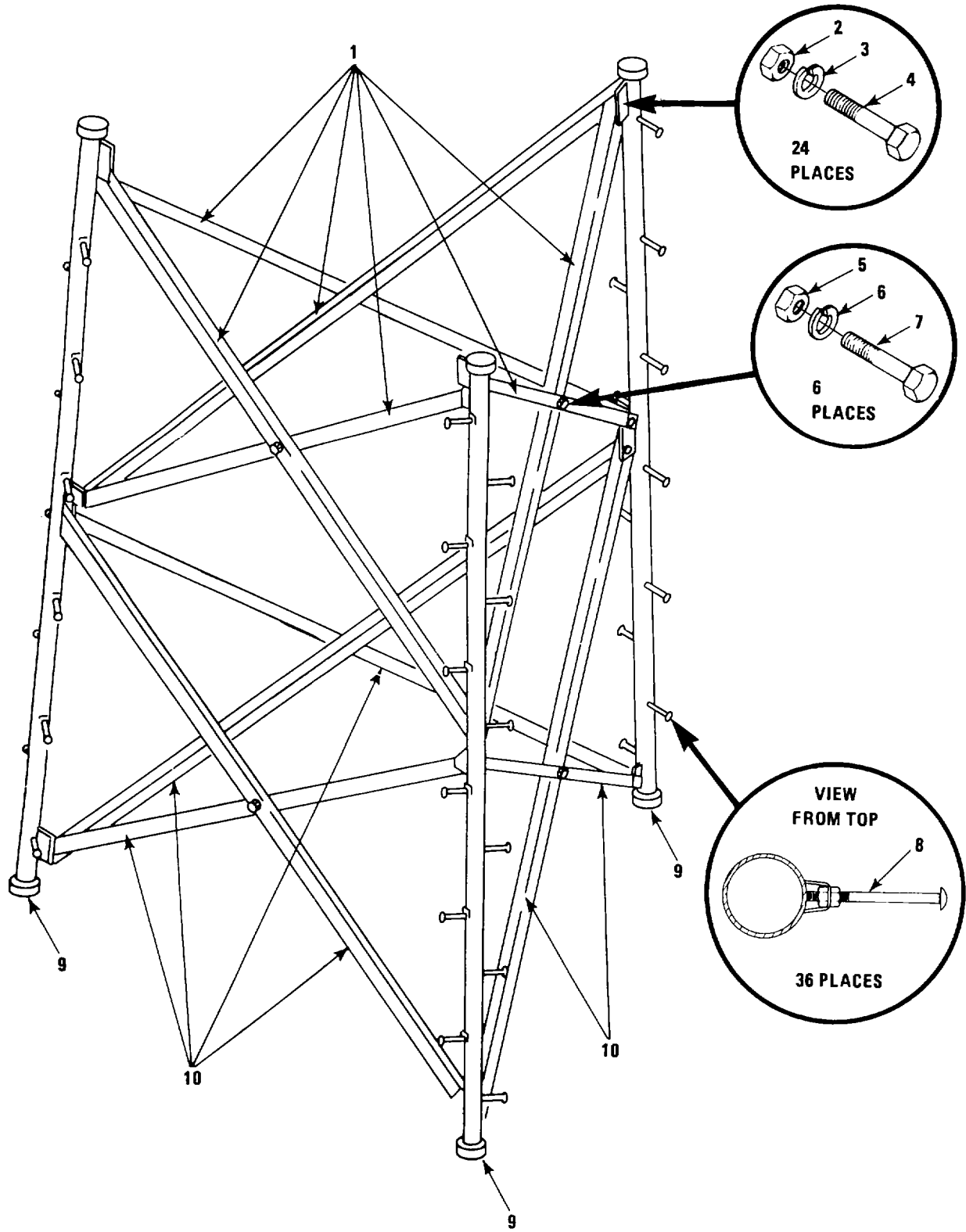

Figure E-2. Tower Section Kit No. 1

Section II. REPAIR PARTS LIST

| (1)<br>ILLUSTRATION |                    | (2)         | (3)                         | (4)            | (5)   | (6)<br>DESCRIPTION                                                | (7) | (8)                      |
|---------------------|--------------------|-------------|-----------------------------|----------------|-------|-------------------------------------------------------------------|-----|--------------------------|
| (a)<br>FIG<br>NO.   | (b)<br>ITEM<br>NO. | SMR<br>CODE | NATIONAL<br>STOCK<br>NUMBER | PART<br>NUMBER | FSCM  | UOC                                                               | U/M | QTY<br>INC<br>IN<br>UNIT |
| E-2                 | 1                  | XBOZZ       |                             | 0261-14014-2   | 15942 | GROUP: 01 TOWER SECTION KIT<br>NO. 1<br>BRACE, TOWER, NO.2        | EA  | 6                        |
| E-2                 | 2                  | PAOZZ       | 5310-00-567-5212            | 2100-0878-001  | 15942 | NUT, HEAVY HEX, 3/4-10 UNC,<br>GALV                               | EA  | 24                       |
| E-2                 | 3                  | XBOZZ       |                             | 2300-0317      | 15942 | WASHER, HEAVY-SPLIT LOCK,<br>3/4, GALV                            | EA  | 24                       |
| E-2                 | 4                  | XBOZZ       |                             | 2076-4370      | 15942 | BOLT, HEX HD, 3/4-10 UNC X<br>1 3/4, GALV                         | EA  | 24                       |
| E-2                 | 5                  | PAOZZ       | 5310-00-401-1991            | 2100-0127      | 15942 | NUT. HEX, 1/2-13 UNC, GALV                                        | EA  | 6                        |
| E-2                 | 6                  | XBOZZ       |                             | 2300-0155      | 15942 | WASHER, SPLIT LOCK, 1/2, GALV                                     | EA  | 6                        |
| E-2                 | 7                  | XBOZZ       |                             | 2077-7347      | 15942 | BOLT. HEX HD, 1/2-13 UNC X 7,<br>CALV                             | EA  | 6                        |
| E-2                 | 8                  | XBOZZ       |                             | 2450-0532      | 15942 | STEP, TOWER, 1/2-13 UNC<br>THREADS, 2 HIGH-STRENGTH<br>NUTS, GALV | EA  | 36                       |
| E-2                 | 9                  | XBOZZ       |                             | 0261-1-4006-1  | 15942 | LEG ASSY, TOWER                                                   | EA  | 3                        |
| E-2                 | 10                 | XBOZZ       |                             | 0261-1-4014-1  | 15942 | BRACE, TOWER, NO. 1                                               | EA  | 6                        |

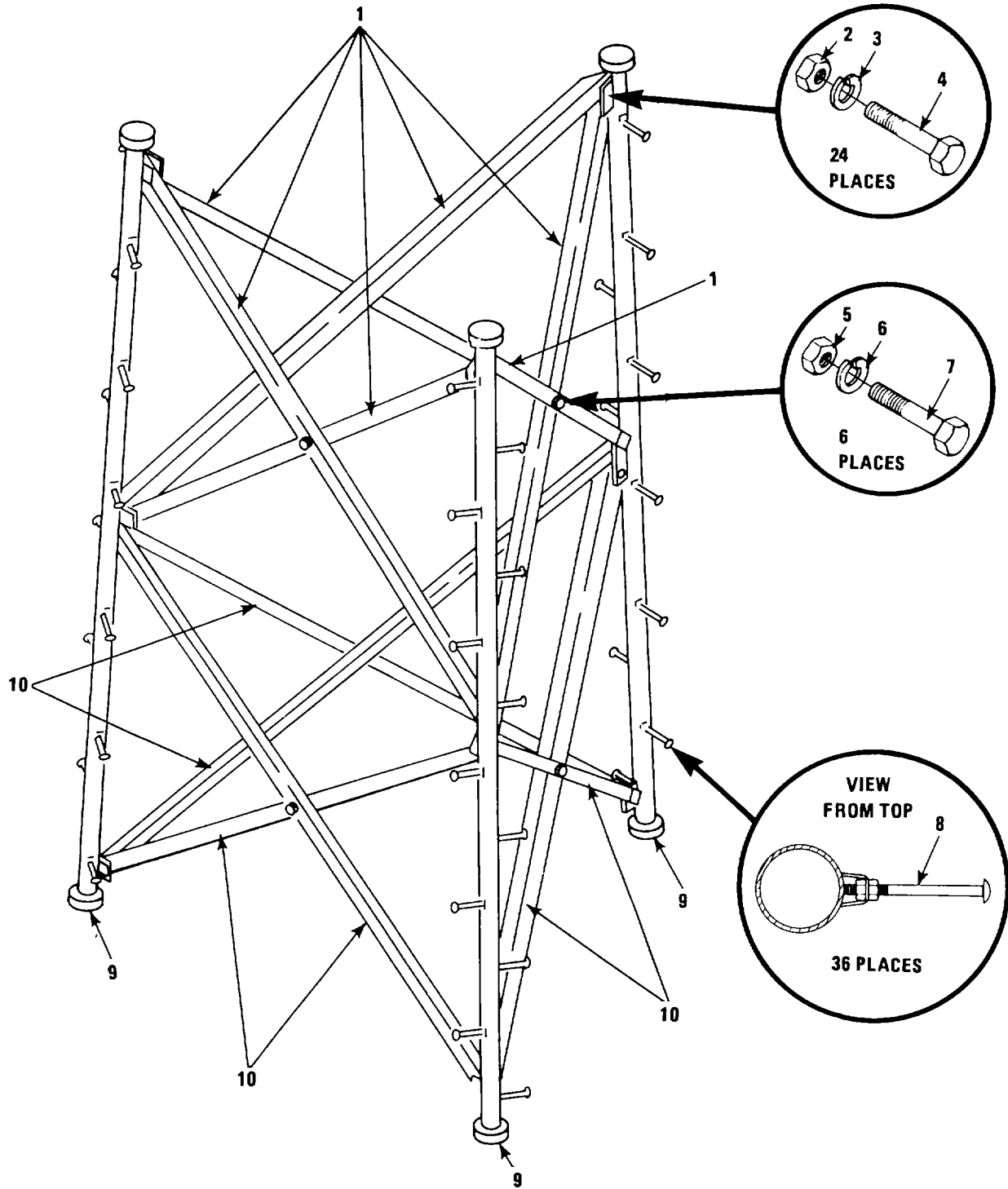

Figure E-3. Tower Section Kit No. 2

Section II. REPAIR PARTS LIST

| (1)<br>ILLUSTRATION |                    | (2)         | (3)                         | (4)            | (5)   | (6)<br>DESCRIPTION                                                | (7) | (8)                      |
|---------------------|--------------------|-------------|-----------------------------|----------------|-------|-------------------------------------------------------------------|-----|--------------------------|
| (a)<br>FIG<br>NO.   | (b)<br>ITEM<br>NO. | SMR<br>CODE | NATIONAL<br>STOCK<br>NUMBER | PART<br>NUMBER | FSCM  | UOC                                                               | U/M | QTY<br>INC<br>IN<br>UNIT |
| E-3                 | 1                  | XBOZZ       |                             | 0261-140144    | 15942 | GROUP: 02 TOWER SECTION KIT<br>NO. 2<br>BRACE, TOWER, NO. 4       | EA  | 6                        |
| E-3                 | 2                  | PAOZZ       | 5310-00-567-5212            | 2100-0878-001  | 15942 | NUT, HEAVY HEX, 3/4-10 UNC,<br>GALV                               | EA  | 24                       |
| E-3                 | 3                  | XBOZZ       |                             | 2300-03 17     | 15942 | WASHER, HEAVY-SPLIT LOCK.<br>3/4, GALV                            | EA  | 24                       |
| E-3                 | 4                  | XBOZZ       |                             | 2076-4370      | 15942 | BOLT. HEX HD. 3/4-10 UNC X<br>1 3/4, GALV                         | EA  | 24                       |
| E-3                 | 5                  | PAOZZ       | 5310-00-401-1991            | 2100-0127      | 15942 | NUT, HEX, 1/2-13 UNC, GALV                                        | EA  | 6                        |
| E-3                 | 1                  | XBOZZ       |                             | 2300-0155      | 15942 | WASHER, SPLIT LOCK, 1/2. GALV                                     | E A | 6                        |
| E-3                 | 7                  | XBOZZ       |                             | 2077-7347      | 15942 | BOLT, HEX HD, 1/2-13 UNC X 7,<br>GALV                             | EA  | 6                        |
| E-3                 | 8                  | XBOZZ       |                             | 2450-0532      | 15942 | STEP, TOWER, 1/2-13 UNC<br>THREADS, 2 HIGH-STRENGTH<br>NUTS, GALV | EA  | 36                       |
| E-3                 | 9                  | XBOZZ       |                             | 0261-14006-1   | 15942 | LEG ASSY, TOWER                                                   | EA  | 3                        |
| E-3                 | 10                 | XBOZZ       |                             | 0261-1-4014-3  | 15942 | BRACE, TOWER, NO. 3                                               | EA  | 6                        |



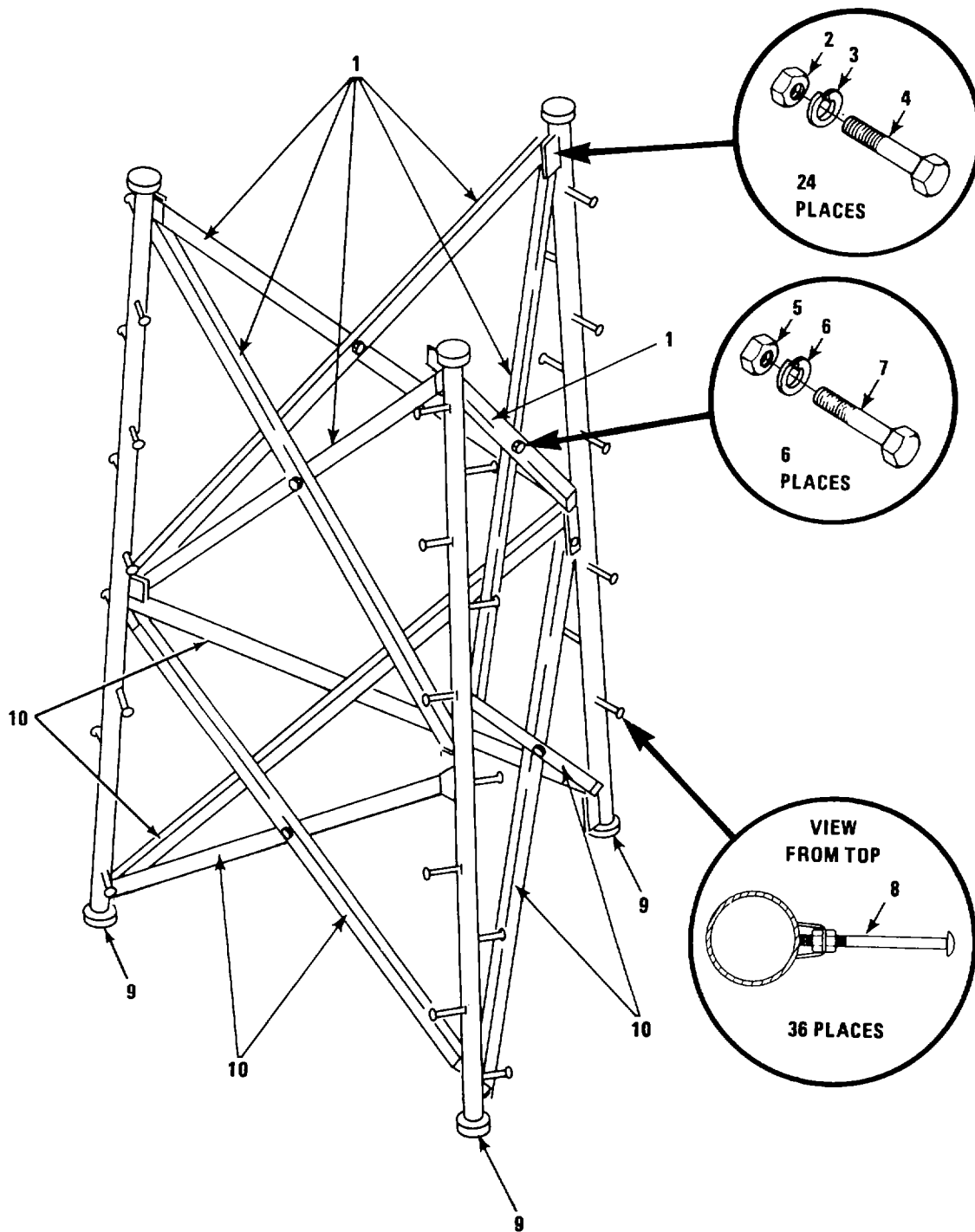

Figure E-4. Tower Section Kit No. 3

Section II. REPAIR PARTS LIST

| (1)<br>ILLUSTRATION |                    | (2)         | (3)                         | (4)            | (5)   | (6)<br>DESCRIPTION                                                | (7) | (8)                      |
|---------------------|--------------------|-------------|-----------------------------|----------------|-------|-------------------------------------------------------------------|-----|--------------------------|
| (a)<br>FIG<br>NO.   | (b)<br>ITEM<br>NO. | SMR<br>CODE | NATIONAL<br>STOCK<br>NUMBER | PART<br>NUMBER | FSCM  | UOC                                                               | U/M | QTY<br>INC<br>IN<br>UNIT |
| E-4                 | 1                  | XBOZZ       |                             | 0261-1-4014-6  | 15942 | GROUP: 03 TOWER SECTION KIT<br>NO. 3<br>BRACE, TOWER, NO. 6       | EA  | 6                        |
| E-4                 | 2                  | PAOZZ       | 5310-00-567-5212            | 2100-0878-001  | 15942 | NUT, HEAVY HEX, 3/4-10 UNC,<br>GALV                               | EA  | 24                       |
| E-4                 | 3                  | XBOZZ       |                             | 2300-03 17     | 15942 | WASHER, HEAVY-SPLIT LOCK,<br>3/4. GALV                            | EA  | 24                       |
| E-4                 | 4                  | XBOZZ       |                             | 20764370       | 15942 | BOLT, HEAVY HEX HD, 3/4-10<br>UNC X 1 3/4, GALV                   | EA  | 24                       |
| E-4                 | 5                  | PAOZZ       | 5310-00-401-1991            | 2100-0127      | 15942 | NUT, HEX. 1/2-13 UNC, GALV                                        | EA  | 6                        |
| E-4                 | 6                  | XBOZZ       |                             | 2300-0155      | 15942 | WASHER, SPLIT LOCK, 1/2, GALV                                     | EA  | 6                        |
| E-4                 | 7                  | XBOZZ       |                             | 2077-7347      | 15942 | BOLT. HEX HD, 1/2-13 UNC X 7,<br>GALV                             | EA  | 6                        |
| E-4                 | 8                  | XBOZZ       |                             | 2450-0532      | 15942 | STEP, TOWER, 1/2-13 UNC<br>THREADS. 2 HIGH-STRENGTH<br>NUTS, GALV | EA  | 36                       |
| E-4                 | 9                  | XBOZZ       |                             | 0261-1-4006-1  | 15942 | LEG ASSY, TOWER                                                   | EA  | 3                        |
| E-4                 | 10                 | XBOZZ       |                             | 0261-14014-5   | 15942 | BRACE, TOWER, NO. 5                                               | EA  | 6                        |

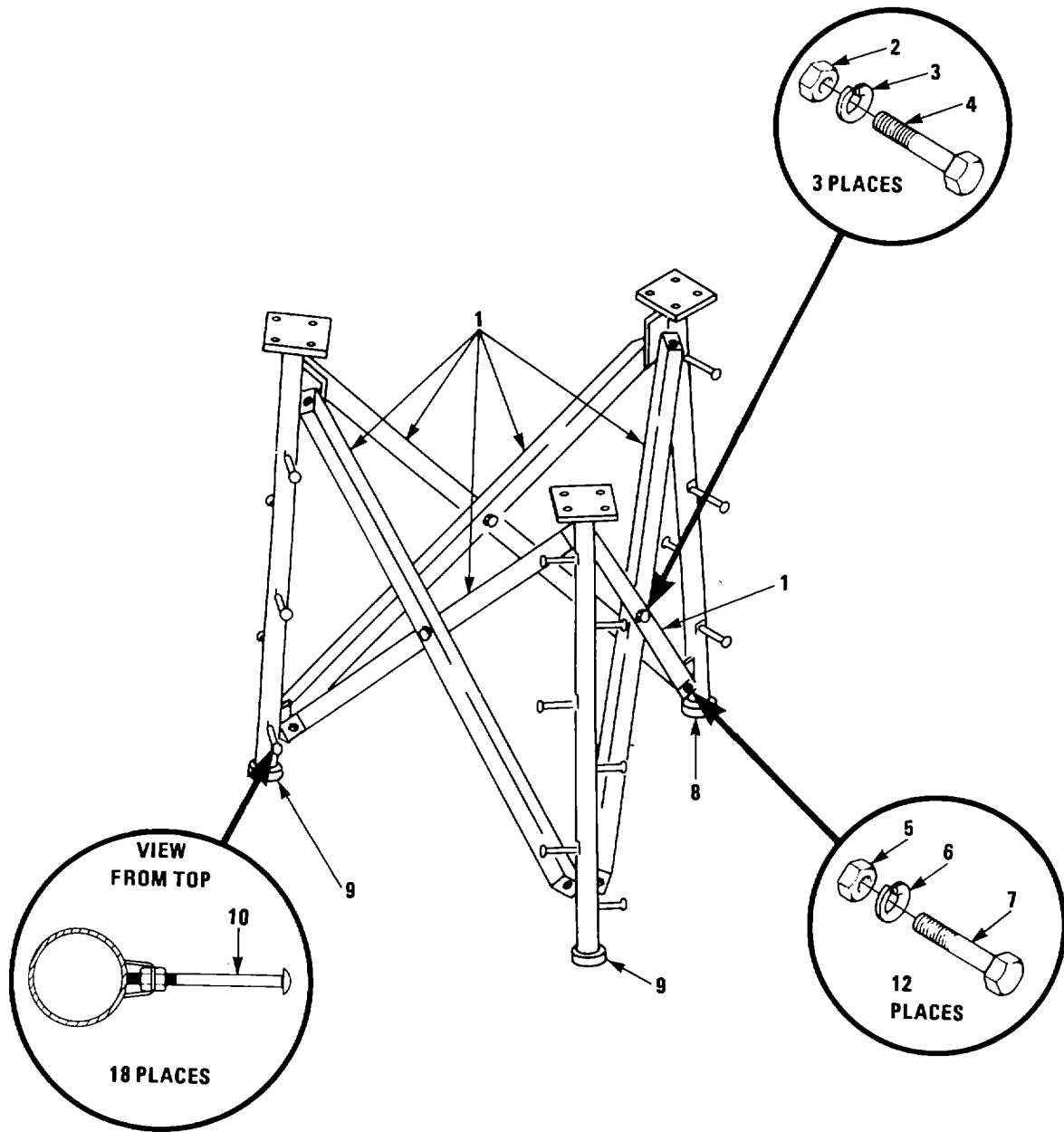

Figure E-5. Tower Section Kit No. 4

Section II. REPAIR PARTS LIST

| (1)<br>ILLUSTRATION |                    | (2)         | (3)                         | (4)            | (5)   | (6)<br>DESCRIPTION                                                | (7) | (8)                      |
|---------------------|--------------------|-------------|-----------------------------|----------------|-------|-------------------------------------------------------------------|-----|--------------------------|
| (a)<br>FIG<br>NO.   | (b)<br>ITEM<br>NO. | SMR<br>CODE | NATIONAL<br>STOCK<br>NUMBER | PART<br>NUMBER | FSCM  | UOC                                                               | U/M | QTY<br>INC<br>IN<br>UNIT |
| E-5                 | 1                  | XBOZZ       |                             | 0261-14014-7   | 15942 | GROUP: 04 TOWER SECTION KIT<br>NO. 4<br>BRACE, TOWER, NO. 7       | EA  | 6                        |
| E-5                 | 2                  | PAOZZ       | 5310-00-401-1991            | 2100-0127      | 15942 | NUT, HEX, 1/2-13 UNC. GALV                                        | EA  | 3                        |
| E-5                 | 3                  | XBOZZ       |                             | 2300-0155      | 15942 | WASHER, SPLIT LOCK, 1/2, GALV                                     | EA  | 3                        |
| E-5                 | 4                  | XBOZZ       |                             | 2077-7347      | 15942 | BOLT, HEX [ID. 1/2-13 UNC X 7,<br>GALV                            | EA  | 3                        |
| E-5                 | 5                  | PAOZZ       | 5310-00-567-5212            | 2100-0878-001  | 15942 | NUT, HEAVY HEX. 3/4-10 UNC.<br>GALV                               | EA  | 12                       |
| E-5                 | 6                  | XBOZZ       |                             | 2300-0317      | 15942 | WASHER, HEAVY-SPLIT LOCK,<br>3/4, GALV                            | EA  | 12                       |
| E-5                 | 7                  | XBOZZ       |                             | 2300-4370      | 15942 | BOLT, HEX HD, 3/4-10 UNC X 1<br>3/4, GALV                         | EA  | 12                       |
| E-5                 | 8                  | XBOZZ       |                             | 0261-14019-2   | 15942 | LEG ASSY, TOWER, TOP. FRONT                                       | EA  | 1                        |
| E-5                 | 9                  | XBOZZ       |                             | 0261-14019-1   | 15942 | LEG ASSY. TOWER, TOP                                              | EA  | 2                        |
| E-5                 | 10                 | XBOZZ       |                             | 2450-0532      | 15942 | STEP, TOWER. 1/2-13 UNC<br>THREADS, 2 HIGH-STRENGTH<br>NUTS, GALV | EA  | 18                       |

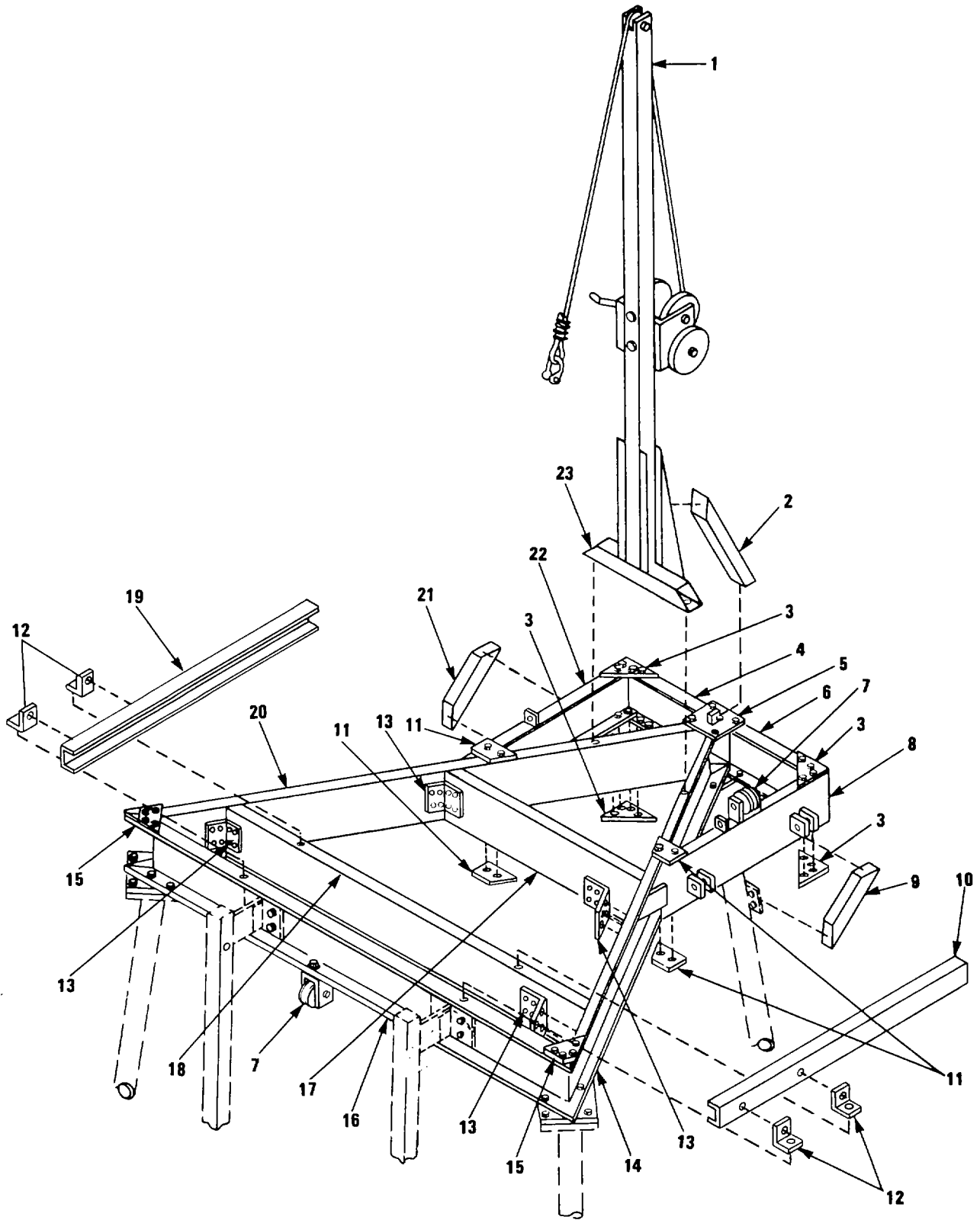

Figure E-6. Tower Adapter Installation (Sheet 1 of 4)

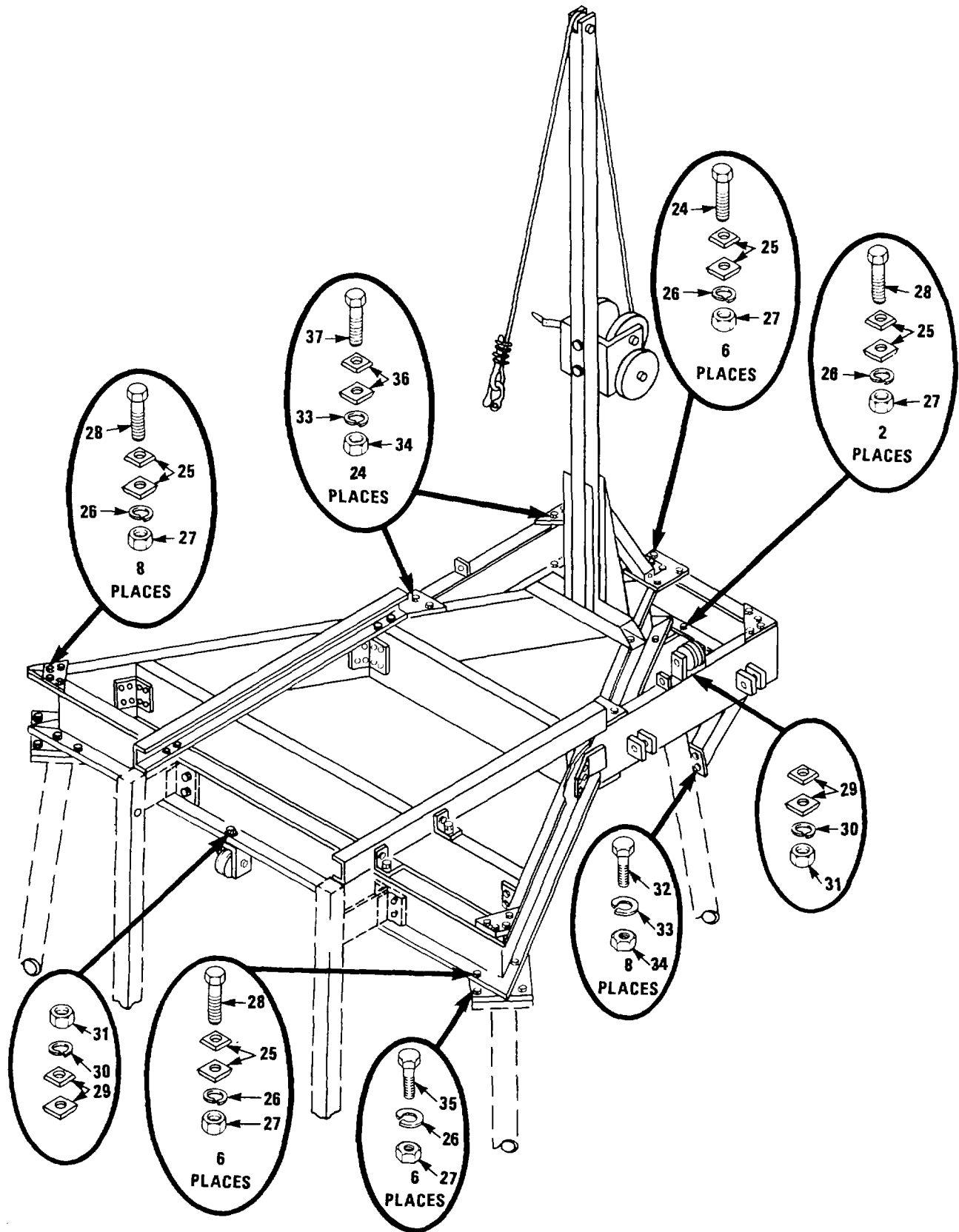

Figure E-6. Tower Adapter Installation (Sheet 2 of 4)

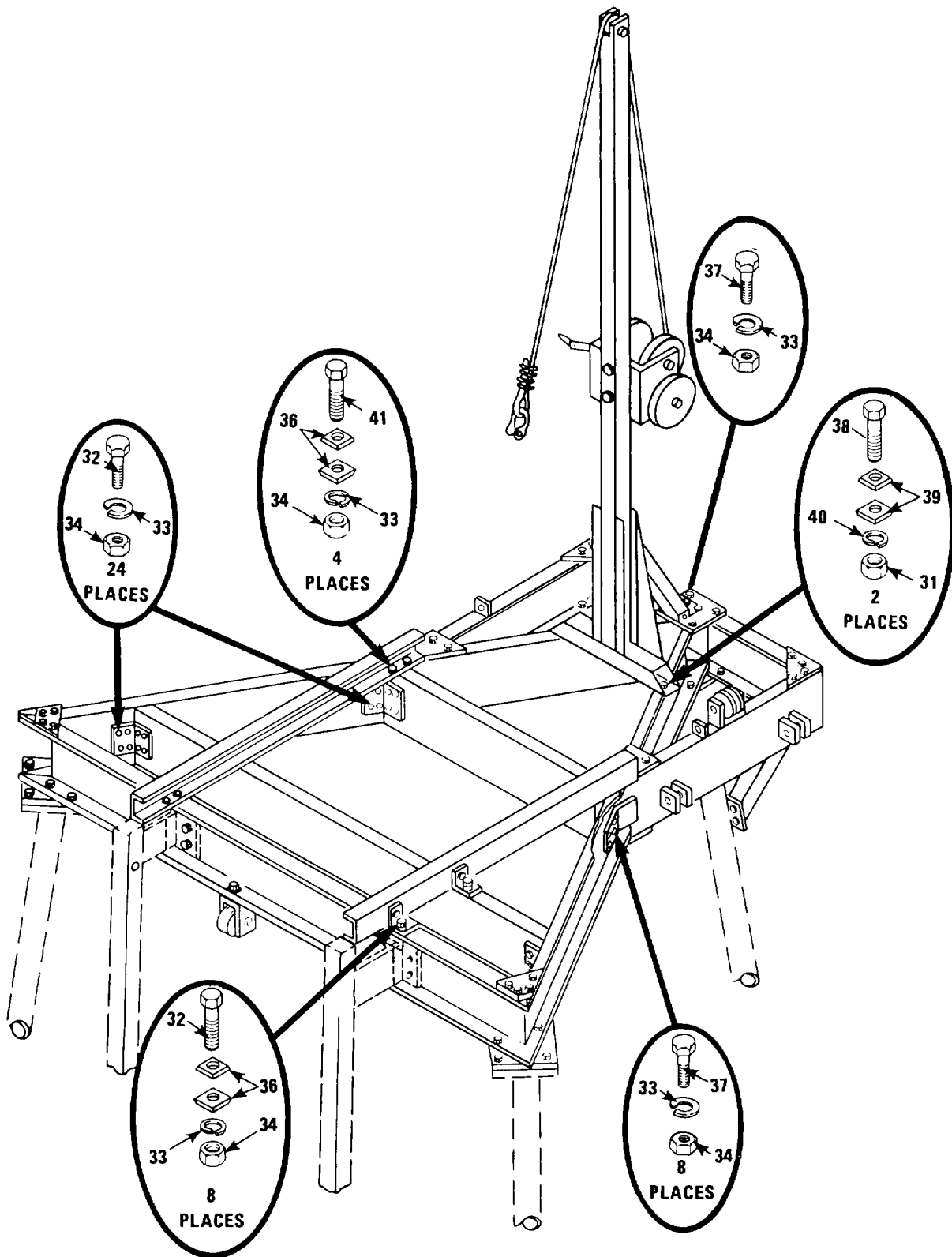

Figure E-6. Tower Adapter Installation (Sheet 3 of 4)

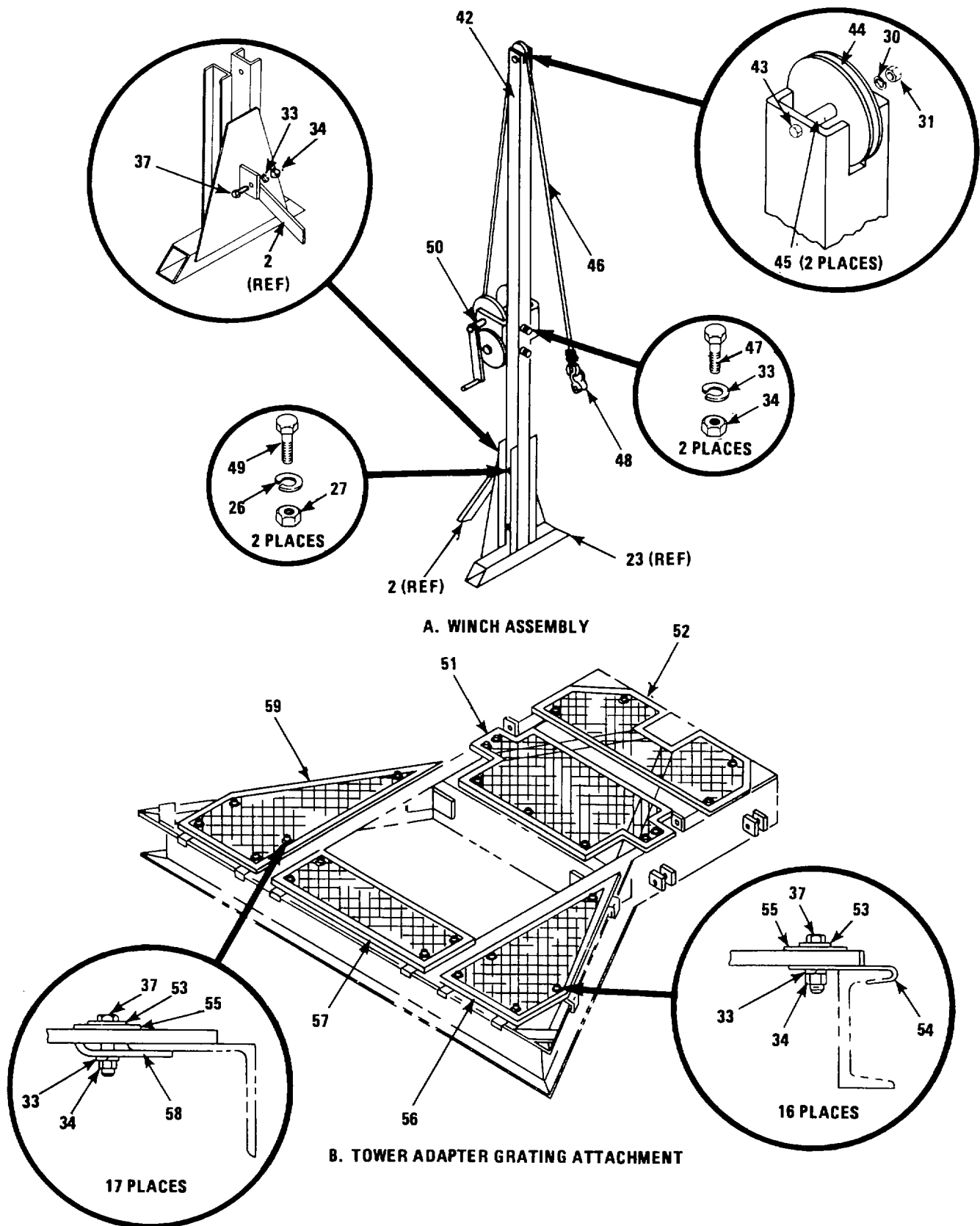

Figure E-6. Tower Adapter Installation (Sheet 4 of 4)



Section II. REPAIR PARTS LIST

| (1)<br>ILLUSTRATION |                    | (2)         | (3)                         | (4)            | (5)   | (6)<br>DESCRIPTION                      | (7) | (8)                      |
|---------------------|--------------------|-------------|-----------------------------|----------------|-------|-----------------------------------------|-----|--------------------------|
| (a)<br>FIG<br>NO.   | (b)<br>ITEM<br>NO. | SMR<br>CODE | NATIONAL<br>STOCK<br>NUMBER | PART<br>NUMBER | FSCM  | UOC                                     | U/M | QTY<br>INC<br>IN<br>UNIT |
|                     |                    |             |                             |                |       | GROUP: 05 TOWER ADAPTER<br>INSTALLATION |     |                          |
| E-6                 | 1                  | XBOFF       |                             | 0261-14055-1   | 15942 | WINCH ASSY, SCAFFOLD                    | EA  | 1                        |
| E-6                 | 2                  | XBOZZ       |                             | 0261-1-2174-1  | 15942 | BRACE, WINCH SUPPORT                    | EA  | 1                        |
| E-6                 | 3                  | XBOZZ       |                             | 0261-1-3026-1  | 15942 | PLATE, CORNER                           | EA  | 4                        |
| E-6                 | 4                  | XBOZZ       |                             | 0261-14062-1   | 15942 | CHANNEL, SCAFFOLD SUPPORT,<br>NO. 1     | EA  | 1                        |
| E-o                 | 5                  | XBOZZ       |                             | 0261-1-3021-1  | 15942 | PLATE, SCAFFOLD SUPPORT                 | EA  | 1                        |
| E-6                 | 6                  | XBOZZ       |                             | 0261-14062-2   | 15942 | CHANNEL, SCAFFOLD SUPPORT.<br>NO. 2     | EA  | 1                        |
| E-6                 | 7                  | PAOZZ       | 3940-00-504-9937            | 0261-1-3042-1  | 15942 | BLOCK ASSY. TACKLE                      | EA  | 2                        |
| E-6                 | 8                  | XBOZZ       |                             | 0261-14134-2   | 15942 | HINGE ASSY, SCAFFOLD, NO. 2             | EA  | 1                        |
| E-6                 | 9                  | XBOZZ       |                             | 0261-14063-1   | 15942 | BRACE, SCAFFOLD SUPPORT,<br>NO. 1       | EA  | 1                        |
| E-6                 | 10                 | XBOZZ       |                             | 0261-1-4047-1  | 15942 | TRACK, HORIZONTAL. NO. 1                | EA  | 1                        |
| E-6                 | 11                 | XBOZZ       |                             | 0261-1-3025-1  | 15942 | PLATE, REINFORCING,<br>SCAFFOLD         | EA  | 4                        |
| E-6                 | 12                 | XBOZZ       |                             | 0261-1-2027-1  | 15942 | ANGLE, TRACK                            | EA  | 4                        |
| E-6                 | 13                 | XBOZZ       |                             | 0261-14023-1   | 15942 | ANGLE, CHANNEL SUPPORT                  | EA  | 4                        |
| E-6                 | 14                 | XBOZZ       |                             | 0261-14041-1   | 15942 | CHANNEL ASSY, SUPPORT, NO. 2            | EA  | 1                        |
| E-6                 | 15                 | XBOZZ       |                             | 0261-1-3022-1  | 15942 | PLATE, CHANNEL TIE                      | EA  | 2                        |
| E-6                 | 16                 | XBOZZ       |                             | 0261-1-3046-1  | 15942 | CHANNEL ASSY, SUPPORT, NO. 1            | EA  | 1                        |
| E-6                 | 17                 | XBOZZ       |                             | 0261-14045-1   | 15942 | BRACE, TRACK, SHORT                     | EA  | 1                        |
| E-6                 | 18                 | XBOZZ       |                             | 0261-14044-1   | 15942 | BRACE, TRACK, LONG                      | EA  | 1                        |
| E-6                 | 19                 | XBOZZ       |                             | 0261-14047-2   | 15942 | TRACK, HORIZONTAL, NO. 2                | EA  | 1                        |
| E-6                 | 20                 | XBOZZ       |                             | 0261-124041-2  | 15942 | CHANNEL ASSY, SUPPORT, NO. 3            | EA  | 1                        |
| E-6                 | 21                 | XBOZZ       |                             | 0261-14063-2   | 15942 | BRACE, SCAFFOLD SUPPORT,<br>NO. 2       | EA  | 1                        |
| E-6                 | 22                 | XBOZZ       |                             | 0261-14134-1   | 15942 | HINGE ASSY, SCAFFOLD, NO. 1             | EA  | 1                        |

Section II. REPAIR PARTS LIST

| (1)<br>ILLUSTRATION |                    | (2)         | (3)                         | (4)            | (5)   | (6)<br>DESCRIPTION                        | (7) | (8)                      |
|---------------------|--------------------|-------------|-----------------------------|----------------|-------|-------------------------------------------|-----|--------------------------|
| (a)<br>FIG<br>NO.   | (b)<br>ITEM<br>NO. | SMR<br>CODE | NATIONAL<br>STOCK<br>NUMBER | PART<br>NUMBER | FSCM  | UOC                                       | U/M | QTY<br>INC<br>IN<br>UNIT |
| E-6                 | 23                 | XBOZZ       |                             | 0261-14053-1   | 15942 | SUPPORT ASSY, WINCH                       | EA  | 1                        |
| E-6                 | 24                 | XBOZZ       |                             | 2077-731 1     | 15942 | BOLT, HEX HD, 1/2-13 UNC X 2,<br>GALV     | EA  | 6                        |
| E-6                 | 25                 | PAOZZ       | 5310-00-250-5668            | 2349-0090      | 15942 | WASHER, SQUARE BEVELED, 1/2,<br>GALV      | EA  | 44                       |
| E-6                 | 26                 | XBOZZ       |                             | 2300-0155      | 15942 | WASHER, SPLIT LOCK, 1/2, GALV             | EA  | 30                       |
| E-6                 | 27                 | PAOZZ       | 5310-00-401-1991            | 2100-0127      | 15942 | NUT, HEX, 1/2-13 UNC. GALV                | EA  | 30                       |
| E-6                 | 28                 | XBOZZ       |                             | 2077-7315      | 15942 | BOLT, HEX HD, 1/2-13 UNC X<br>2 1/2, GALV | EA  | 16                       |
| E-6                 | 29                 | XBOZZ       |                             | 2349-0091      | 15942 | WASHER, SQUARE BEVELED, 5/8,<br>GALV      | EA  | 4                        |
| E-6                 | 30                 | XBOZZ       |                             | 2300-0157      | 15942 | WASHER, SPLIT LOCK, 5/8, GALV             | EA  | 3                        |
| E-6                 | 31                 | PAOZZ       | 5310-00-401-1990            | 2100-0131      | 15942 | NUT, HEX, 5/8-11 UNC, GALV                | EA  | 5                        |
| E-6                 | 32                 | PAOZZ       | 5306-00-478-0406            | 2077-6808      | 15942 | BOLT, HEX HD, 3/8-16 UNC X 1 1/4<br>GALV  | EA  | 8                        |
| E-6                 | 33                 | XBOZZ       |                             | 2300-0153      | 15942 | WASHER, SPLIT LOCK, 3/8, GALV             | EA  | 117                      |
| E-6                 | 34                 | XBOZZ       |                             | 2100-0123      | 15942 | NUT, HEX, 3/8-16 UNC, GALV                | EA  | 117                      |
| E-6                 | 35                 | XBOZZ       |                             | 2077-7309      | 15942 | BOLT. HEX HD, 1/2-13 UNC X<br>1 3/4, GALV | EA  | 6                        |
| E-6                 | 36                 | XBOZZ       |                             | 2349-0029-005  | 15942 | WASHER, SQUARE BEVELED.<br>3/8, GALV      | EA  | 72                       |
| E-6                 | 37                 | XBOZZ       |                             | 2077-6812      | 15942 | BOLT, HEX HD, 3/8-16 UNC X<br>1 3/4, GALV | EA  | 67                       |
| E-6                 | 38                 | XBOZZ       |                             | 2077-7907      | 15942 | BOLT, HEX HD, 5/8-11 UNC X<br>1 3/4, GALV | EA  | 2                        |
| E-6                 | 39                 | XBOZZ       |                             | 2349-0091      | 15942 | WASHER, BEVELED, 5/8, GALV                | EA  | 4                        |
| E-6                 | 40                 | XBOZZ       |                             | 2300-0157      | 15942 | WASHER, SPLIT LOCK, 5/8, GALV             | EA  | 2                        |
| E-6                 | 41                 | XBOZZ       |                             | 2077-8813      | 15942 | BOLT, HEX HD, 3/8-16 UNC X<br>1 1/2, GALV | EA  | 4                        |
| E-6                 | 42                 | XBOZZ       |                             | 0261-1-4056-1  | 15942 | SUPPORT, WINCH                            | EA  | 1                        |
| E-6                 | 43                 | XBOZZ       |                             | 2077-7925      | 15942 | BOLT, HEX HD, 5/8-11 UNC<br>X 1 3/4, GALV | EA  | 1                        |
| E-6                 | 44                 | XBOZZ       |                             | 1173           | 75535 | SHEAVE                                    | EA  | 1                        |

Section II. REPAIR PARTS LIST

| (1)<br>ILLUSTRATION |                    | (2)         | (3)                         | (4)            | (5)   | (6)<br>DESCRIPTION                       | (7) | (8)                      |
|---------------------|--------------------|-------------|-----------------------------|----------------|-------|------------------------------------------|-----|--------------------------|
| (a)<br>FIG<br>NO.   | (b)<br>ITEM<br>NO. | SMR<br>CODE | NATIONAL<br>STOCK<br>NUMBER | PART<br>NUMBER | FSCM  | UOC                                      | U/M | QTY<br>INC<br>IN<br>UNIT |
| E-6                 | 45                 | XBOZZ       |                             | 0261-1-2054-1  | 15942 | SPACER, PULLEY                           | EA  | 2                        |
| E-6                 | 46                 | XBOZZ       |                             | 0261-1-3061-1  | 15942 | WIRE ROPE ASSY                           | EA  | 1                        |
| E-6                 | 47                 | XBOZZ       |                             | 2077-6829      | 15942 | BOLT, HEX HD, 3/8-16 UNC X<br>3 3/4      | EA  |                          |
| E-6                 | 48                 | XBOZZ       |                             | 2350-1103      | 15942 | SHACKLE, CHAIN, 3/8. GALV                | EA  | 1                        |
| E-6                 | 49                 | XBOZZ       |                             | 2077-6834      | 15942 | BOLT. HEX HD. 12-13 UNC X<br>4 1/4, GALV | EA  | 2                        |
| E-6                 | 50                 | PAOZZ       | 3950-00-102-6266            | 40612          | 12437 | WINCH, DRUM, HAND                        | EA  | 1                        |
| E-6                 | 51                 | XBOZZ       |                             | 0261-1-4171-1  | 15942 | GRATING ASSY, TOWER, NO. 5               | EA  | 1                        |
| E-6                 | 52                 | XBOZZ       |                             | 0261-1-4059-1  | 15942 | GRATING ASSY, TOWER, NO. 3               | EA  | 1                        |
| E-6                 | 53                 | XBOZZ       |                             | 2310-0138      | 15942 | WASHER, FLAT, 3/8. GALV                  | E A | 34                       |
| E-6                 | 54                 | XBOZZ       |                             | 0261-1-3166-1  | 15942 | CLAMP, GRATING, NO. 2                    | EA  | 16                       |
| E-6                 | 55                 | XBOZZ       |                             | 2310-0612      | 15942 | WASHER, FLAT. 3/4, GALV                  | EA  | 34                       |
| E-6                 | 56                 | XBOZZ       |                             | 0261-1-4058-1  | 15942 | GRATING ASSY, TOWER, NO. 1               | EA  | 1                        |
| E-6                 | 57                 | XBOZZ       |                             | 0261-1-3060-1  | 15942 | GRATING ASSY. TOWER, NO. 4               | EA  | 1                        |
| E-6                 | 58                 | XBOZZ       |                             | 0261-1-2166-1  | 15942 | CLAMP, GRATING, NO. 1                    | EA  | 17                       |
| E-6                 | 59                 | XBOZZ       |                             | 0261-1-4058-2  | 15942 | GRATING ASSY, TOWER, NO. 2               | EA  | 1                        |

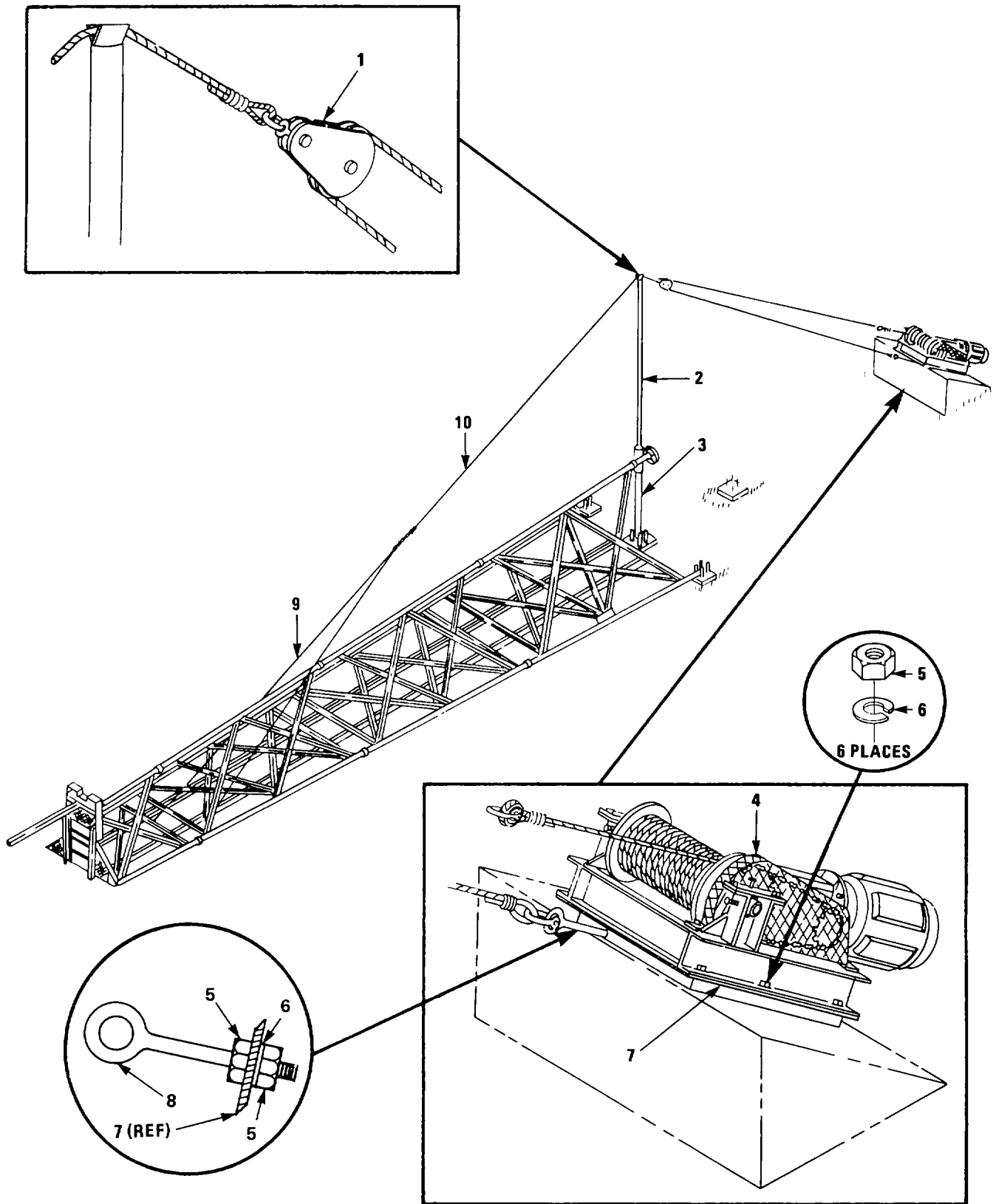
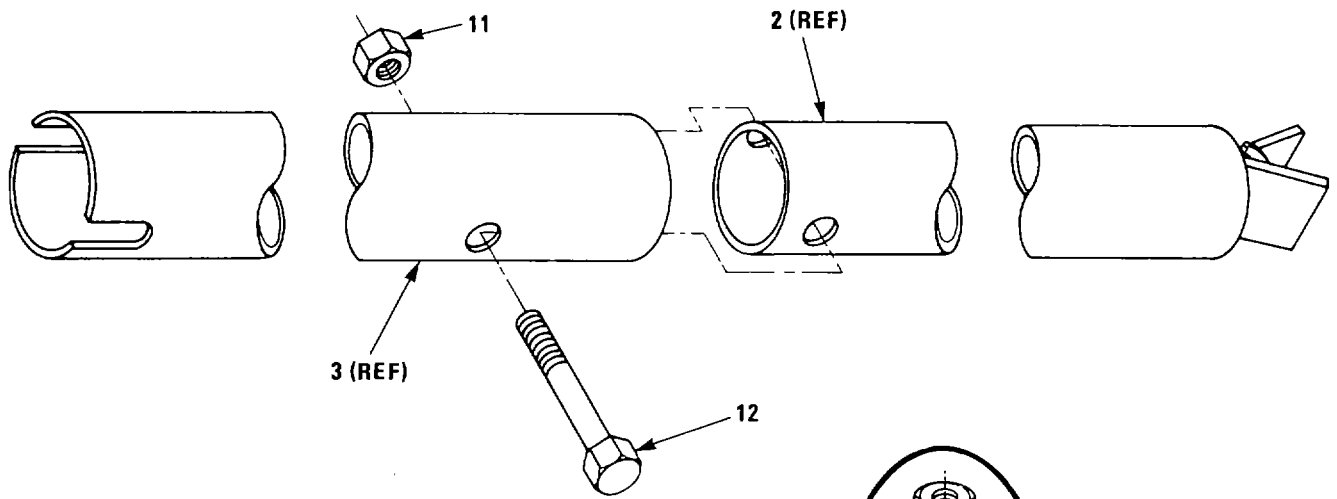
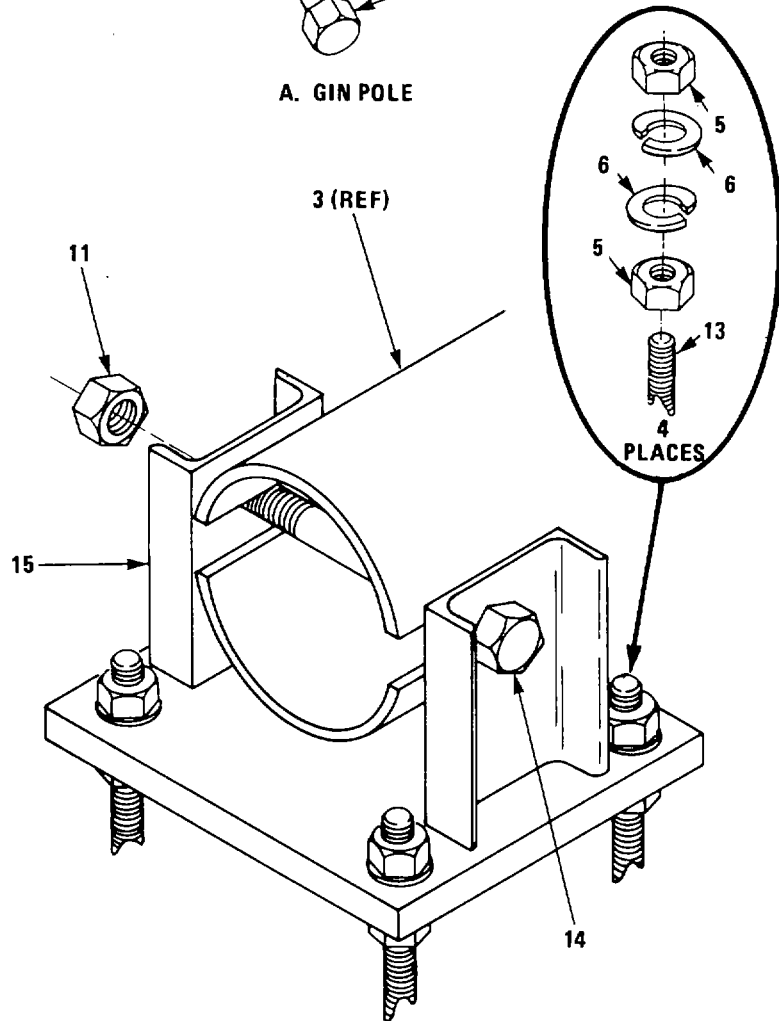

Figure E-7. Tower Erection Kit (Sheet 1 of 2)



A. GIN POLE



B. GIN POLE BOTTOM SECTION AND PIVOT BASE ASSEMBLY

Figure E-7. Tower Erection Kit (Sheet 2 of 2)

Section II. REPAIR PARTS LIST

| (1)<br>ILLUSTRATION |                    | (2)         | (3)                         | (4)            | (5)   | (6)<br>DESCRIPTION                      | (7) | (8)                      |
|---------------------|--------------------|-------------|-----------------------------|----------------|-------|-----------------------------------------|-----|--------------------------|
| (a)<br>FIG<br>NO.   | (b)<br>ITEM<br>NO. | SMR<br>CODE | NATIONAL<br>STOCK<br>NUMBER | PART<br>NUMBER | FSCM  | UOC                                     | U/M | QTY<br>INC<br>IN<br>UNIT |
|                     |                    |             |                             |                |       | GROUP: 06 TOWER ERECTION<br>KIT         |     |                          |
| E-7                 | 1                  | XBOZZ       |                             | L-45-S         | 75535 | BLOCK, SNATCH                           | EA  | 1                        |
| E-7                 | 2                  | XBOZZ       |                             | 0261-1-2083-1  | 15942 | GIN POLE TOP SECTION                    | EA  | 1                        |
| E-7                 | 3                  | XBOZZ       |                             | 0261-1-3084-1  | 15942 | GIN POLE BOTTOM SECTION                 | EA  | 1                        |
| E-7                 | 4                  | XBODD       |                             | 0261-1-3173-1  | 15942 | HOIST ASSY, TOWER                       | EA  | 1                        |
| E-7                 | 5                  | PAOZZ       | 5310-00-401-1988            | 2100-0137      | 15942 | NUT, HEX, 1-8 UNC. GALV                 | EA  | 16                       |
| E-7                 | 6                  | XBOZZ       |                             | 2300-0163      | 15942 | WASHER, SPLIT LOCK, GALV                | EA  | 16                       |
| E-7                 | 7                  | XBOZZ       |                             | 0261-1-4101-1  | 15942 | FRAME ASSY, HOIST                       | EA  | 1                        |
| E-7                 | 8                  | XBOZZ       |                             | 2450-0449      | 15942 | BOLT, EYE, 1-8 UNC X 12. GALV           | EA  | 2                        |
| E-7                 | 9                  | XBOZZ       |                             | 0261-1-4124-1  | 15942 | SLING ASSY. MULTIPLE-LEG                | EA  | 1                        |
| E-7                 | 10                 | XBOZZ       |                             | 0261-1-3125-1  | 15942 | CABLE. ERECTION                         | EA  | 1                        |
| E-7                 | 11                 | PAOZZ       | 5310-00-401-1989            | 2100-0149      | 15942 | NUT, HEX, I 1/2-6 UNC, GALV             | EA  | 1                        |
| E-7                 | 12                 | XBOZZ       |                             | 2077-9255      | 15942 | BOLT, HEX HD, 1 1/2-6 X 11,<br>GALV     | EA  | 1                        |
| E-7                 | 13                 | XBOZZ       |                             | 0261-1-3094-1  | 15942 | BOLT, ANCHOR                            | EA  | 4                        |
| E-7                 | 14                 | XBOZZ       |                             | 2077-9257      | 15942 | BOLT, HEX ID, I 1/2-6 UNC X 12,<br>GALV | EA  | 1                        |
| E-7                 | 15                 | XBOZZ       |                             | 0261-14088-2   | 15942 | BASE ASSY, PIVOT. GIN POLE              | EA  | 1                        |

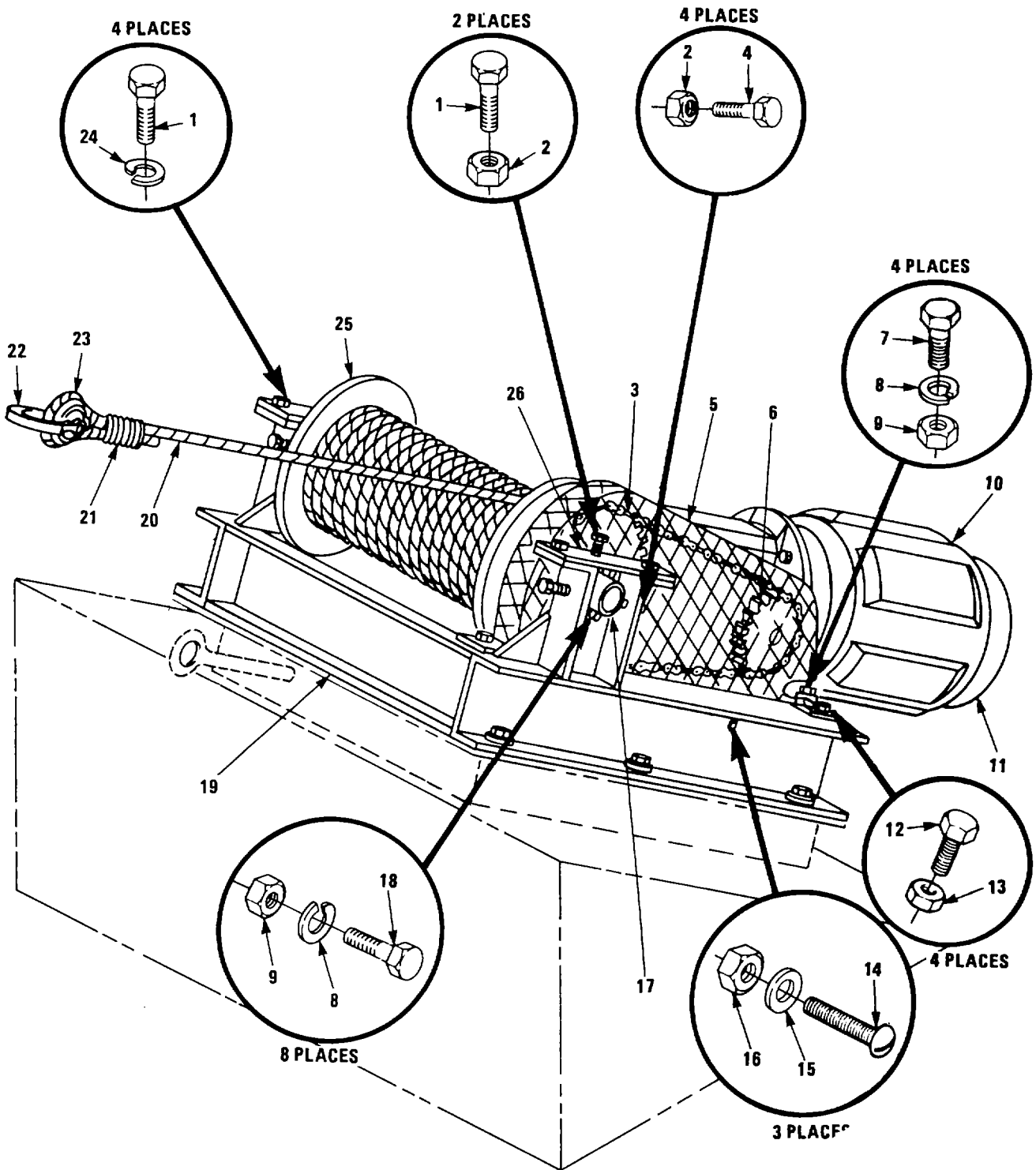

Figure E-8. Tower Hoist

## Section II. REPAIR PARTS LIST

| (1)<br>ILLUSTRATION |                    | (2)         | (3)                         | (4)              | (5)   | (6)<br>DESCRIPTION                                    | (7) | (8)                      |
|---------------------|--------------------|-------------|-----------------------------|------------------|-------|-------------------------------------------------------|-----|--------------------------|
| (a)<br>FIG<br>NO.   | (b)<br>ITEM<br>NO. | SMR<br>CODE | NATIONAL<br>STOCK<br>NUMBER | PART<br>NUMBER   | FSCM  | UOC                                                   | U/M | QTY<br>INC<br>IN<br>UNIT |
| E-8                 | 1                  | XBOZZ       |                             | 1/2NCX1- /4      | 06550 | GROUP: 0601 TOWER HOIST<br>BOLT, CAP                  | EA  | 6                        |
| E-8                 | 2                  | XBOZZ       |                             | 1/2NC            | 06550 | JAM NUT, CHAIN TENSION                                | EA  | 10                       |
| E-8                 | 3                  | XBOZZ       |                             | 120-50LINK       | 06550 | CHAIN                                                 | EA  | 1                        |
| E-8                 | 4                  | XBOZZ       |                             | 1/2NCX-2         | 06550 | BOLT, CHAIN TENSION                                   | EA  | 4                        |
| E-8                 | 5                  | XBOZZ       |                             | 2047             | 06550 | GUARD, CHAIN                                          | EA  | 1                        |
| E-8                 | 6                  | XBOZZ       |                             | 120-B-11T        | 06550 | SPROCKET, MOTOR, 2 1/8 BORE                           | EA  | 1                        |
| E-8                 | 7                  | XBOZZ       |                             | 5/8NCX2-1/4      | 06550 | BOLT. CAP                                             | EA  | 4                        |
| E-8                 | 8                  | XBOZZ       |                             | 5/8DIA-MED       | 06550 | WASHER, LOCK                                          | EA  | 12                       |
| E-8                 | 9                  | XBOZZ       |                             | 5/8NC-HEAVY      | 06550 | NUT, HEX                                              | EA  | 12                       |
| E-8                 | 10                 | XBOZZ       |                             | CG28ATYPE-<br>PD | 50380 | MOTOR, 5 HP, 27 RPM, 3 PHASE,<br>60 Hz, 230/460 VOLTS | EA  | 1                        |
| E-8                 | 11                 | XBOZZ       |                             | 87000            | 05805 | BRAKE, 25 FT-LB                                       | EA  | 1                        |
| E-8                 | 12                 | XBOZZ       |                             | 5/16NCX1-1/4     | 06550 | BOLT, CAP                                             | EA  | 4                        |
| E-8                 | 13                 | XBOZZ       |                             | 5/16NC           | 06550 | NUT, SELF-LOCKING                                     | EA  | 4                        |
| E-8                 | 14                 | XBOZZ       |                             | 10-24MS          | 06550 | SCREW, MACHINE                                        | EA  | 3                        |
| E-8                 | 15                 | XBOZZ       |                             | 1/4DIA           | 06550 | WASHER, FLAT                                          | EA  | 3                        |
| E-8                 | 16                 | XBOZZ       |                             | 10/24NUT         | 06550 | NUT, HEX                                              | EA  | 3                        |
| E-8                 | 17                 | XBOZZ       |                             | 2-3/16 RCJ       | 21335 | BEARING                                               | EA  | 2                        |
| E-8                 | 18                 | XBOZZ       |                             | 1072             | 06550 | BOLT LOCK, BEARING                                    | EA  | 8                        |
| E-8                 | 19                 | XBOZZ       |                             | B5114            | 06550 | FRAME, HOIST                                          | EA  | 1                        |
| E-8                 | 20                 | XBOZZ       |                             | 2630-0032        | 15942 | CABLE, AIRCRAFT, 5/8 DIA,<br>GALV                     | FT  | 150                      |
| E-8                 | 21                 | XBOZZ       |                             | 2350-3014        | 15942 | SWAGING SLEEVE, WIRE ROPE                             | EA  | 1                        |
| E-8                 | 22                 | XBOZZ       |                             | 2350-1257        | 15942 | SHACKLE, ANCHOR, 3.2 TON                              | EA  | 1                        |
| E-8                 | 23                 | XBOZZ       |                             | 2350-0048        | 15942 | THIMBLE, WIRE ROPE, 3/4 IN.                           | EA  | 1                        |
| E-8                 | 24                 | XBOZZ       |                             | 1/2 DIA-MED      | 06550 | WASHER, LOCK                                          | EA  | 4                        |
| E-8                 | 25                 | XBOZZ       |                             | 2044             | 06550 | DRUM                                                  | EA  | 1                        |
| E-8                 | 26                 | XBOZZ       |                             | 1929             | 06550 | CAP, UPRIGHT                                          | EA  | 2                        |



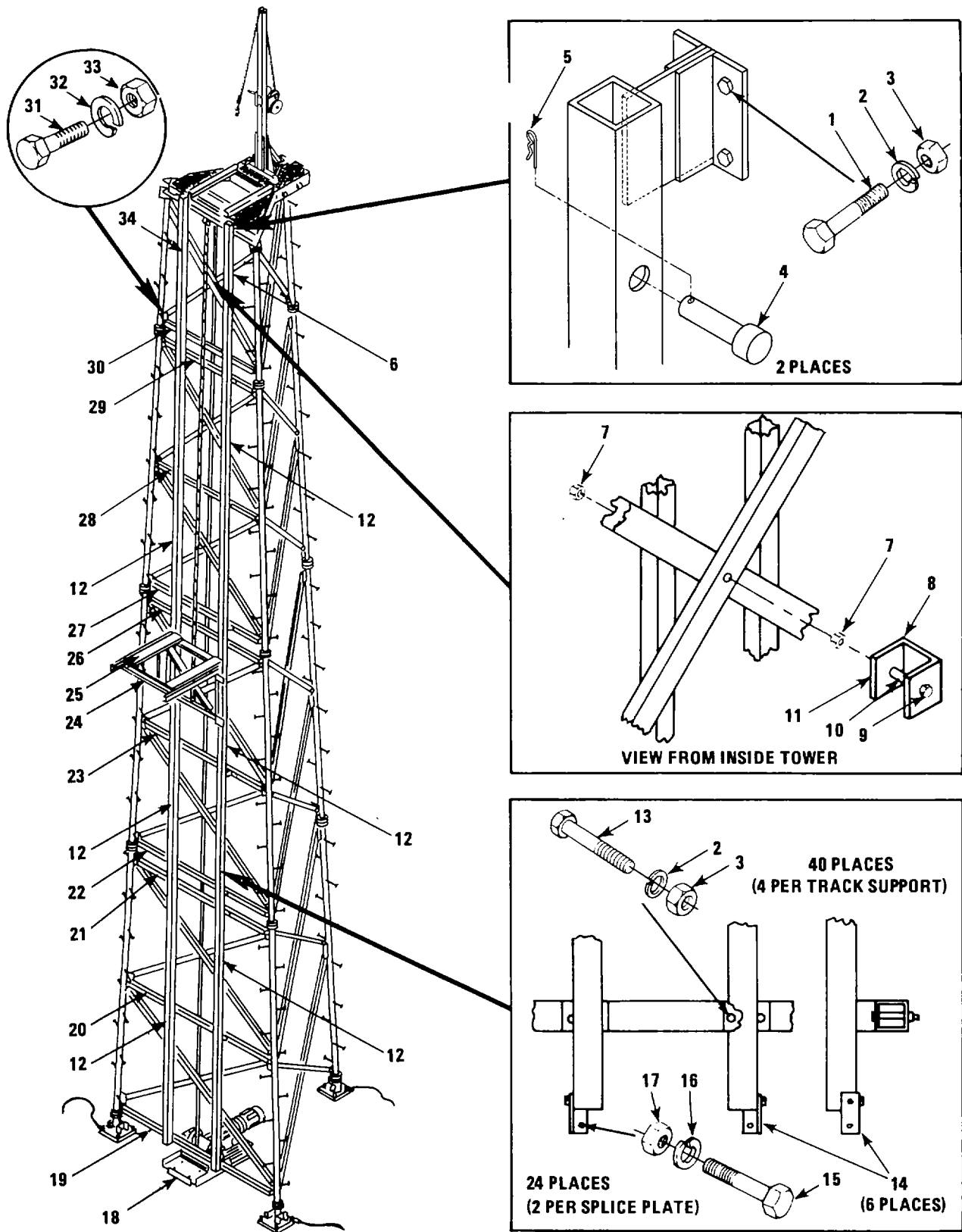

Figure E-9. Antenna Elevator and Carriage Installation

Section II. REPAIR PARTS LIST

| (1)<br>ILLUSTRATION |                    | (2)         | (3)                         | (4)            | (5)   | (6)<br>DESCRIPTION                                         | (7) | (8)                      |
|---------------------|--------------------|-------------|-----------------------------|----------------|-------|------------------------------------------------------------|-----|--------------------------|
| (a)<br>FIG<br>NO.   | (b)<br>ITEM<br>NO. | SMR<br>CODE | NATIONAL<br>STOCK<br>NUMBER | PART<br>NUMBER | FSCM  | UOC                                                        | U/M | QTY<br>INC<br>IN<br>UNIT |
|                     |                    |             |                             |                |       | GROUP: 07 ANTENNA ELEVATOR<br>AND CARRIAGE<br>INSTALLATION |     |                          |
| E-9                 | 1                  | XBOZZ       |                             | 2077-7305      | 15942 | BOLT, HEX HD, 1/2-3 UNC X<br>1 1/4                         | EA  | 4                        |
| E-9                 | 2                  | XBOZZ       |                             | 2300-0155      | 15942 | WASHER, SPLIT LOCK, 1/2. GALV                              | EA  | 44                       |
| E-9                 | 3                  | PAOZZ       | 5310-00-401-1991            | 2100-01 7      | 15942 | NUT, HEX. 1/2-13 UNC, GALV                                 | EA  | 44                       |
| E-9                 | 4                  | XBOZZ       |                             | 0261-1-3164-1  | 15942 | SHEAR PIN                                                  | EA  | 2                        |
| E-9                 | 5                  | PAOZZ       | 5315-00-934-0230            | LSP3           | 96652 | PIN, RETAINING                                             | EA  | 2                        |
| E-9                 | 6                  | XBOZZ       |                             | 0261-1-4075-1  | 15942 | TRACK ASSY, TOP, NO. 1                                     | EA  | 1                        |
| E-9                 | 7                  | PAOZZ       | 5310-00-439-2626            | 210 0227       | 15942 | NUT, HEX, 1/2-13, SST                                      | EA  | 2                        |
| E-9                 | 8                  | XBOZZ       |                             | 0261-1-2185-1  | 15942 | GUIDE ASSY, ROPE                                           | EA  | 1                        |
| E-9                 | 9                  | XBOZZ       |                             | 2078-3319      | 15942 | BOLT, HEX HD, 1/2-13 UNC X 3,<br>SST                       | EA  | 1                        |
| E-9                 | 10                 | XBOZZ       |                             | 0261-1-2187-1  | 15942 | ROLLER, GUIDE                                              | EA  | 1                        |
| E-9                 | 11                 | XBOZZ       |                             | 0261-1-2186-1  | 15942 | BRACKET, GUIDE                                             | EA  | 1                        |
| E-9                 | 12                 | XBOZZ       |                             | 0261-1-4081-1  | 15942 | TRACK ASSY                                                 | EA  | 6                        |
| E-9                 | 13                 | XBOZZ       |                             | 2077-7327      | 15942 | BOLT, HEX HD, 1/2-13 UNC X 4,<br>GALV                      | EA  | 40                       |
| E-9                 | 14                 | XBOZZ       |                             | 0261-1-2112-1  | 15942 | PLATE, SPLICE                                              | EA  | 6                        |
| E-9                 | 15                 | PAOZZ       | 5306-00-478-0406            | 2077-6808      | 15942 | BOLT, HEX HD, 3/8-16 UNC X<br>3/4, GALV                    | EA  | 24                       |
| E-9                 | 16                 | XBOZZ       |                             | 2300-0153      | 15942 | WASHER. SPLIT LOCK, 3/8, GALV                              | EA  | 24                       |
| E-9                 | 17                 | XBOZZ       |                             | 2100-0123      | 15942 | NUT, HEX, 3/8-16 UNC, GALV                                 | EA  | 24                       |
| E-9                 | 18                 | XBOZZ       |                             | 0261-14133-1   | 15942 | HOIST ASSY. ELEVATOR                                       | EA  | 1                        |
| E-9                 | 19                 | XBOZZ       |                             | 0261-14015-1   | 15942 | SUPPORT, TRACK, NO. 1                                      | EA  | 1                        |
| E-9                 | 20                 | XBOZZ       |                             | 0261-1-4015-2  | 15942 | SUPPORT, TRACK, NO. 2                                      | EA  | 1                        |
| E-9                 | 21                 | XBOZZ       |                             | 0261-14015-3   | 15942 | SUPPORT, TRACK, NO. 3                                      | EA  | 1                        |
| E-9                 | 22                 | XBOZZ       |                             | 0261-14015-4   | 15942 | SUPPORT, TRACK, NO. 4                                      | EA  | 1                        |
| E-9                 | 23                 | XBOZZ       |                             | 0261-1-4015-5  | 15942 | SUPPORT, TRACK, NO. 5                                      | EA  | 1                        |

Section II. REPAIR PARTS LIST

| (1)<br>ILLUSTRATION |                    | (2)         | (3)                         | (4)            | (5)   | (6)<br>DESCRIPTION                        | (7) | (8)                      |
|---------------------|--------------------|-------------|-----------------------------|----------------|-------|-------------------------------------------|-----|--------------------------|
| (a)<br>FIG<br>NO.   | (b)<br>ITEM<br>NO. | SMR<br>CODE | NATIONAL<br>STOCK<br>NUMBER | PART<br>NUMBER | FSCM  | UOC                                       | U/M | QTY<br>INC<br>IN<br>UNIT |
| E-9                 | 24                 | XBOFF       |                             | 0261-1-4034-1  | 15942 | CARRIAGE ASSEMBLY, ANTENNA                | EA  | 1                        |
| E-9                 | 25                 | XBOFF       |                             | 0261-1-4128-1  | 15942 | ELEVATOR ASSEMBLY                         | EA  | 1                        |
| E-9                 | 26                 | XBOZZ       |                             | 0261-14015-6   | 15942 | SUPPORT, TRACK, NO. 6                     | EA  | 1                        |
| E-9                 | 27                 | XBOZZ       |                             | 0261-1-4015-7  | 15942 | SUPPORT, TRACK. NO. 7                     | EA  | 1                        |
| E-9                 | 28                 | XBOZZ       |                             | 0261-1-4015-8  | 15942 | SUPPORT, TRACK, NO. 8                     | EA  | 1                        |
| E-9                 | 29                 | XBOZZ       |                             | 0261-1-4015-9  | 15942 | SUPPORT, TRACK. NO. 9                     | EA  | 1                        |
| E-9                 | 30                 | XBOZZ       |                             | 0261-1-4015-10 | 15942 | SUPPORT. TRACK, NO. 10                    | EA  | 1                        |
| E-9                 | 31                 | XBOZZ       |                             | 20764370       | 15942 | BOLT. HEX HD, 3/4-10 UNC X<br>1 3/4, GALV | EA  | 20                       |
| E-9                 | 32                 | XBOZZ       |                             | 2300-0317      | 15942 | WASHER, HEAVY-SPLIT LOCK,<br>3/4, GALV    | EA  | 20                       |
| E-9                 | 33                 | PAOZZ       | 5310-00-567-5212            | 2100-0878-001  | 15942 | NUT, HEAVY HEX, 3/4-10 UNC,<br>GALV       | EA  | 20                       |
| E-9                 | 34                 | XBOZZ       |                             | 0261-1-4075-2  | 15942 | TRACK ASSY, TOP, NO. 2                    | EA  | 1                        |

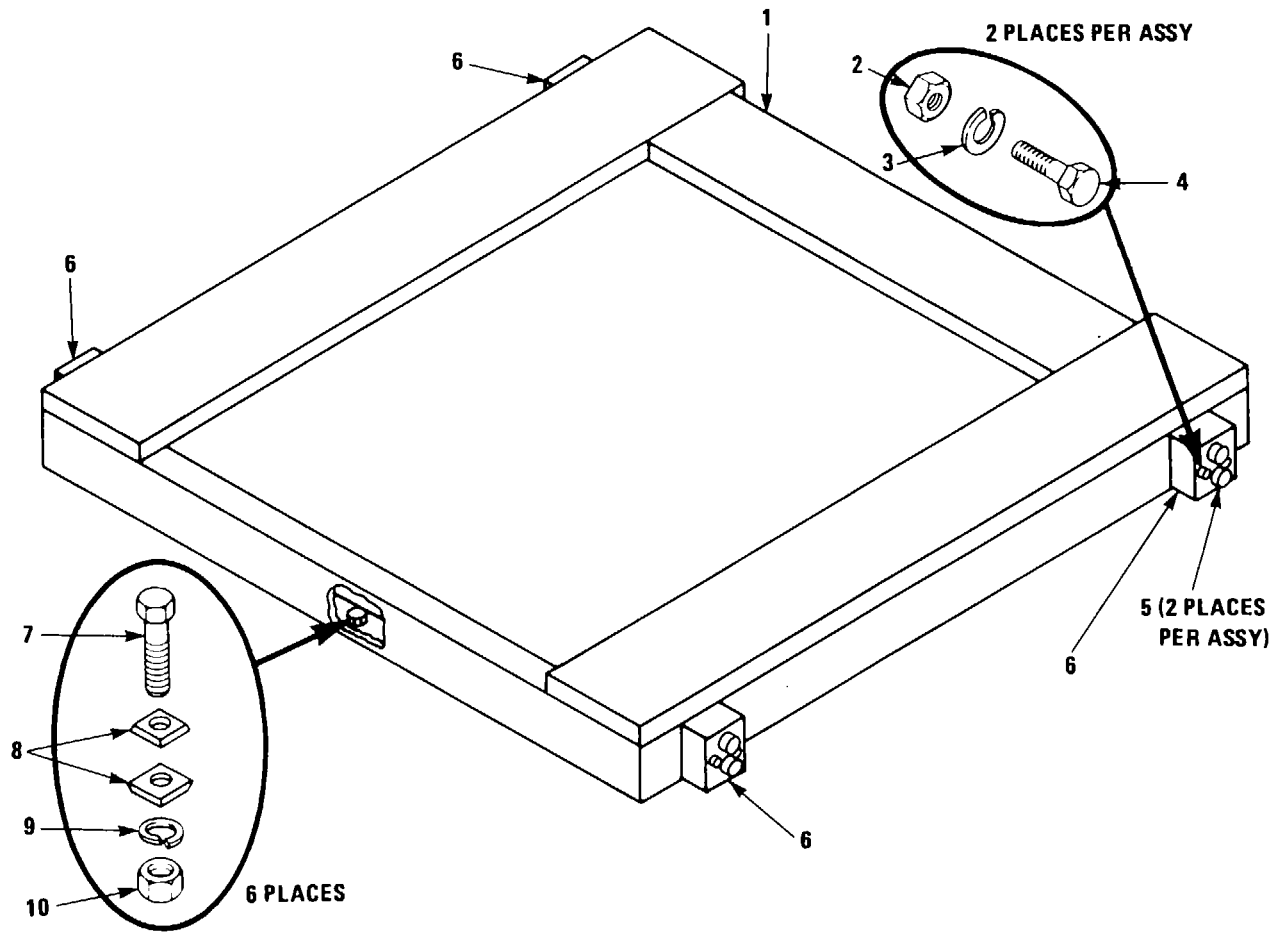

Figure E-10. Antenna Carriage Assembly

(E-33 Blank)/E-34

Section II. REPAIR PARTS LIST

| (1)<br>ILLUSTRATION |                    | (2)         | (3)                         | (4)            | (5)   | (6)<br>DESCRIPTION                                                | (7) | (8)                      |
|---------------------|--------------------|-------------|-----------------------------|----------------|-------|-------------------------------------------------------------------|-----|--------------------------|
| (a)<br>FIG<br>NO.   | (b)<br>ITEM<br>NO. | SMR<br>CODE | NATIONAL<br>STOCK<br>NUMBER | PART<br>NUMBER | FSCM  | UOC                                                               | U/M | QTY<br>INC<br>IN<br>UNIT |
| E-10                | 1                  | XBOZZ       |                             | 0261-1.4033-1  | 15942 | GROUP: 0701 ANTENNA<br>CARRIAGE ASSEMBLY<br><br>CARRIAGE, ANTENNA | EA  | 1                        |
| E-10                | 2                  | XBOZZ       |                             | 2100-0223      | 15942 | NUT, HEX, 3/8-16 UNC, SST                                         | EA  | 8                        |
| E-10                | 3                  | XBOZZ       |                             | 2300-0911      | 15942 | WASHER, SPLIT LOCK, 3/8, SST                                      | EA  | 8                        |
| E-10                | 4                  | XBOZZ       |                             | 2078-2818      | 15942 | BOLT, HEX HD, 3/8-16 UNC X<br>2 1/2, SST                          | EA  | 8                        |
| E-10                | 5                  | XBOZZ       |                             | H-32-SW        | 45014 | CAM FOLLOWER                                                      | EA  | 8                        |
| E-10                | 6                  | XBOZZ       |                             | 0261-1-3032-1  | 15942 | BLOCK, CAM FOLLOWER                                               | EA  | 4                        |
| E-10                | 7                  | XBOZZ       |                             | 2077-6814      | 15942 | BOLT. HEX HD, 3/8-16 UNC X 2,<br>GALV                             | EA  | 6                        |
| E-10                | 8                  | XBOZZ       |                             | 2349-0029-005  | 15942 | WASHER. SQUARE BEVELED, 3/8<br>GALV                               | EA  | 12                       |
| E-10                | 9                  | XBOZZ       |                             | 2300-0053      | 15942 | WASHER, SPLIT LOCK, 3/8, GALV                                     | EA  | 6                        |
| E-10                | 10                 | XBOZZ       |                             | 2100-0123      | 15942 | NUT, HEX, 3/8-16 UNC, GALV                                        | EA  | 6                        |

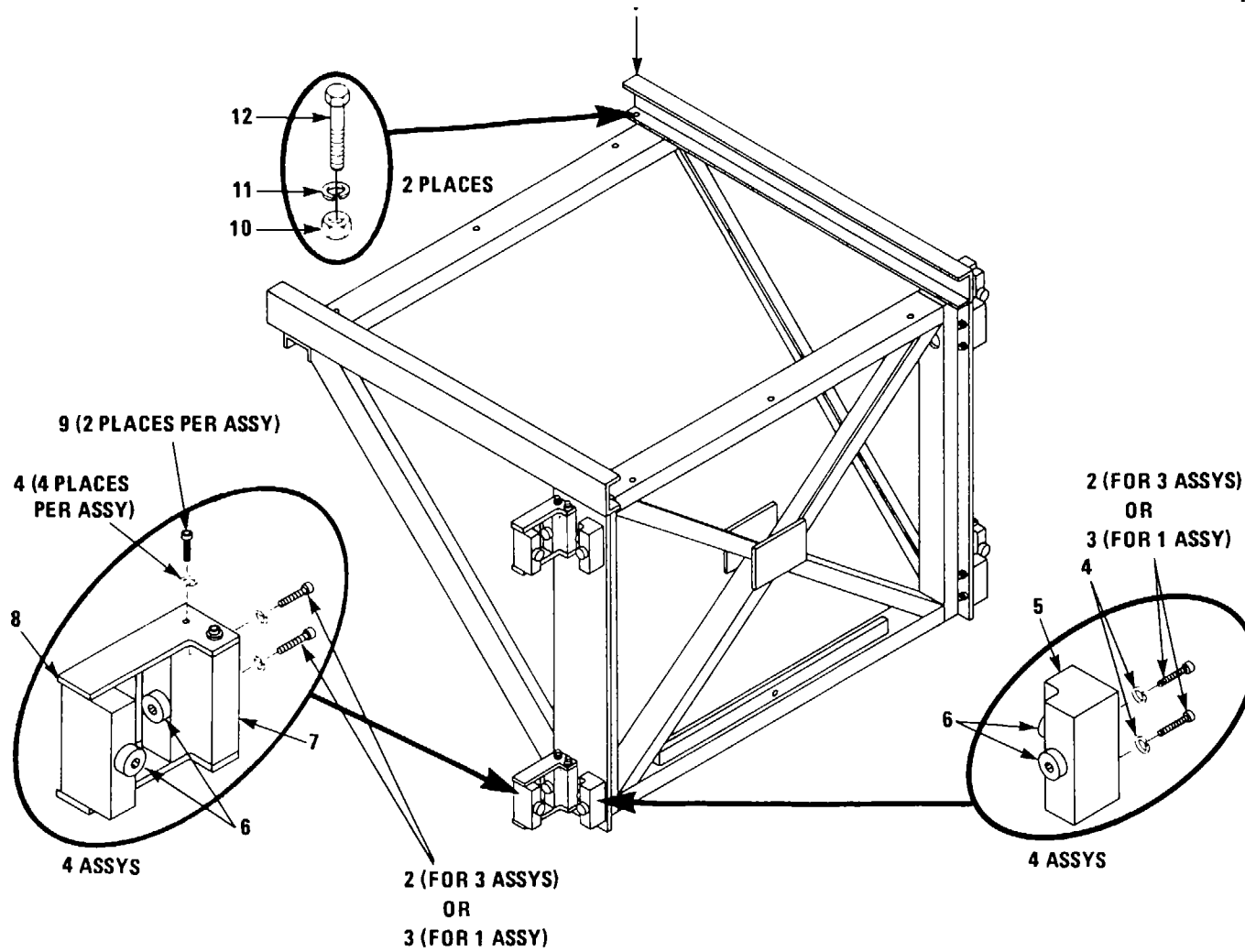

Figure E-11. Elevator Assembly

Section II. REPAIR PARTS LIST

| (1)<br>ILLUSTRATION |                    | (2)         | (3)                         | (4)            | (5)   | (6)<br>DESCRIPTION                                    | (7) | (8)                      |
|---------------------|--------------------|-------------|-----------------------------|----------------|-------|-------------------------------------------------------|-----|--------------------------|
| (a)<br>FIG<br>NO.   | (b)<br>ITEM<br>NO. | SMR<br>CODE | NATIONAL<br>STOCK<br>NUMBER | PART<br>NUMBER | FSCM  | UOC                                                   | U/M | QTY<br>INC<br>IN<br>UNIT |
| E-11                | 1                  | XBOZZ       |                             | 0261-1-4127-1  | 15942 | GROUP: 0702 ELEVATOR<br>ASSEMBLY<br>ELEVATOR WELDMENT | EA  | 1                        |
| E-11                | 2                  | XBOZZ       |                             | 2027-1484      | 15942 | SCREW, CAP, SOCKET HD, 112-13<br>UNC X 1 3/4          | EA  | 12                       |
| E-11                | 3                  | XBOZZ       |                             | 2027-1482      | 15942 | SCREW. CAP, SOCKET HD. 1/2-13<br>UNC X 1 1/4          | EA  | 4                        |
| E-11                | 4                  | XBOZZ       |                             | 2300-0055      | 15942 | WASHER, SPLIT LOCK, 1/2. GALV                         | EA  | 32                       |
| E-11                | 5                  | XBOZZ       |                             | 0261-1-3102-1  | 15942 | BLOCK. MOUNTING, CAM<br>FOLLOWER. NO. 1               | LA  | 4                        |
| E-11                | 6                  | XBOZZ       |                             | H-32-SW        | 45014 | CAM FOLLOWER                                          | EA  | 16                       |
| E-11                | 7                  | XBOZZ       |                             | 0261-1-3102-2  | 15942 | BLOCK, MOUNTING, CAM<br>FOLLOWER, NO. 2               | EA  | 4                        |
| E-11                | 8                  | XBOZZ       |                             | 0261-1-3182    | 15942 | MOUNT ASSY, CAM FOLLOWER                              | EA  | 4                        |
| E-11                | 9                  | XBOZZ       |                             | 2027-1479      | 15942 | SCREW, CAP, SOCKET HD. 1/2-13<br>UNC X 7/8            | EA  | 8                        |
| E-11                | 10                 | XBOZZ       |                             | 2100-0123      | 15942 | NUT, HEX. 3/8-16 UNC, GALV                            | EA  | 2                        |
| E-11                | 11                 | XBOZZ       |                             | 2300-0053      | 15942 | WASHER, SPLIT LOCK, 3/8, GALV                         | EA  | 2                        |
| E-11                | 12                 | XBOZZ       |                             | 2077-6806      | 15942 | BOLT, HEX HD, 3/8-16 UNC X 1,<br>GALV                 | EA  | 2                        |

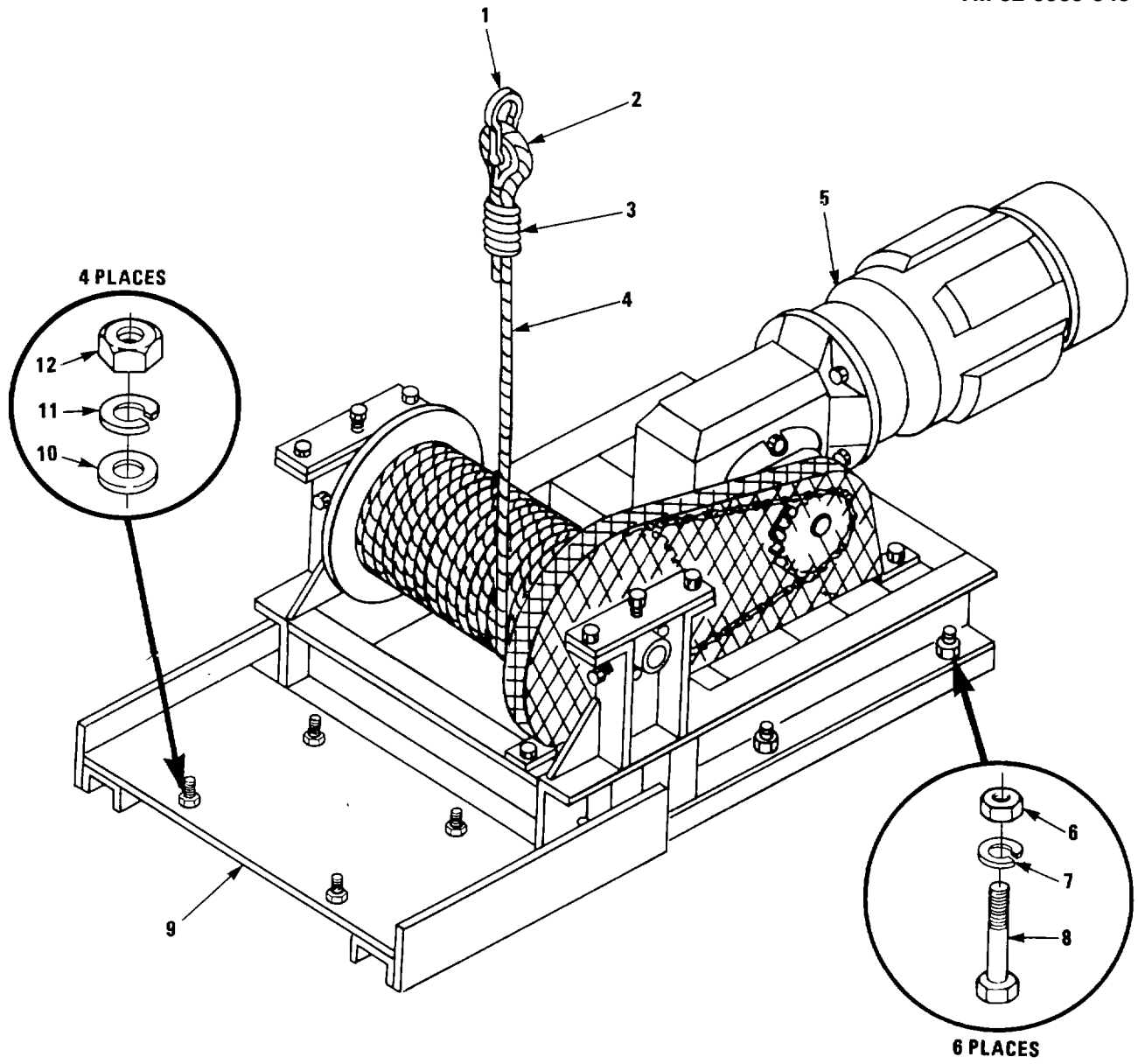

Figure E-12. Elevator Hoist



Section II. REPAIR PARTS LIST

| (1)<br>ILLUSTRATION |                    | (2)         | (3)                         | (4)            | (5)   | (6)<br>DESCRIPTION                                   | (7) | (8)                      |
|---------------------|--------------------|-------------|-----------------------------|----------------|-------|------------------------------------------------------|-----|--------------------------|
| (a)<br>FIG<br>NO.   | (b)<br>ITEM<br>NO. | SMR<br>CODE | NATIONAL<br>STOCK<br>NUMBER | PART<br>NUMBER | FSCM  | UOC                                                  | U/M | QTY<br>INC<br>IN<br>UNIT |
| E-12                | 1                  | XBOZZ       |                             | 2350-1253      | 15942 | GROUP: 0703 ELEVATOR HOIST<br>SHACKLE, ANCHOR, 8 TON | EA  | 1                        |
| E-12                | 2                  | XBOZZ       |                             | 2350-0044      | 15942 | THIMBLE, WIRE ROPE. 3/8                              | EA  | 1                        |
| E-12                | 3                  | XBOZZ       |                             | 2350-3010      | 15942 | SWAGGING SLEEVE, WIRE ROPE.<br>3/8                   | EA  | 1                        |
| E-12                | 4                  | XBOZZ       |                             | 2630-0340      | 15942 | CABLE. WIRE, 3/8 DIA. GALV                           | FT  | 150                      |
| E-12                | 5                  | XBODD       |                             | 2000B20        | 06550 | HOIST, ELECTRIC                                      | EA  | 1                        |
| E-12                | 6                  | PAOZZ       | 5310-00-401-1990            | 2100-0131      | 15942 | NUT, 5/8- 11 UNC. GALV                               | EA  | 6                        |
| E-12                | 7                  | XBOZZ       |                             | 2300-0157      | 15942 | WASHER, SPLIT LOCK. 5/8,<br>GALV                     | EA  | 6                        |
| E-2                 | 8                  | XBOZZ       |                             | 2077-7907      | 15942 | BOLT. HEX HD, 5/8-11 UNC X<br>1-3/4, GALV            | EA  | 6                        |
| E-12                | 9                  | XBOZZ       |                             | 0261-1-4130-1  | 15942 | MOUNT, ELEVATOR HOIST                                | EA  | 1                        |
| E-12                | 10                 | XBOZZ       |                             | 2310-0618      | 15942 | WASHER, FLAT, 1, GALV                                | EA  | 4                        |
| E-12                | 11                 | XBOZZ       |                             | 2300-0163      | 15942 | WASHER, SPLIT LOCK, 1, GALV                          | EA  | 4                        |
| E-12                | 12                 | PAOZZ       | 5310-00-401-1988            | 2100-0137      | 15942 | NUT, HEX, 1-8 UNC, GALV                              | EA  | 4                        |

Section III. REPAIR PARTS LIST

| (1)<br>ILLUSTRATION |                    | (2)         | (3)                         | (4)            | (5)  | (6)<br>DESCRIPTION | (7) | (8)                      |
|---------------------|--------------------|-------------|-----------------------------|----------------|------|--------------------|-----|--------------------------|
| (a)<br>FIG<br>NO.   | (b)<br>ITEM<br>NO. | SMR<br>CODE | NATIONAL<br>STOCK<br>NUMBER | PART<br>NUMBER | FSCM | UOC                | U/M | QTY<br>INC<br>IN<br>UNIT |
| (NOT APPLICABLE)    |                    |             |                             |                |      |                    |     |                          |

Section IV. NATIONAL STOCK NUMBER AND PART NUMBER INDEX

| NATIONAL STOCK NUMBER | FIGURE NUMBER | ITEM NO. | NATIONAL STOCK NUMBER | FIGURE NUMBER | ITEM NO. |
|-----------------------|---------------|----------|-----------------------|---------------|----------|
| 3950-00-102-6266      | E-6           | 50       | 5310-00-401-1991      | E-5           | 2        |
| 5985-00-168-9392      | E-1           | 2        | 5310-00-401-1991      | E-6           | 27       |
| 5985-00-168-9394      | E-1           | 7        | 5310-00-401-1991      | E-9           | 3        |
| 5310-00-250-5668      | E-6           | 25       | 5310-00-439-2626      | E-9           | 7        |
| 5310-00-401-1988      | E-1           | 13       | 5306-00-478-0406      | E-6           | 32       |
| 5310-00-401-1988      | E-7           | 5        | 5306-00-478-0406      | E-9           | 15       |
| 5310-00-401-1988      | E-12          | 12       | 3940-00-504-9937      | E-6           | 7        |
| 5310-00-401-1989      | E-1           | 20       | 5310-00-567-5212      | E-1           | 9        |
| 5310-00-401-1989      | E-7           | 11       | 5310-00-567-5212      | E-2           | 2        |
| 5310-00-401-1990      | E-6           | 31       | 5310-00-567-5212      | E-3           | 2        |
| 5310-00-401-1990      | E-12          | 6        | 5310-00-567-5212      | E-4           | 2        |
| 5310-00-401-1991      | E-2           | 5        | 5310-00-567-5212      | E-5           | 5        |
| 5310-00-401-1991      | E-3           | 5        | 5310-00-567-5212      | E-9           | 33       |
| 5310-00-401-1991      | E-4           | 5        | 5315-00-934-0230      | E-9           | 5        |

Section IV. NATIONAL STOCK NUMBER AND PART NUMBER INDEX

| PART NUMBER   | FSCM  | FIG. NO. | ITEM NO. | PART NUMBER    | FSCM  | FIG NO. | ITEM NO. |
|---------------|-------|----------|----------|----------------|-------|---------|----------|
| B5114         | 06550 | E-8      | 19       | 0261-1-4006-1  | 15942 | E-2     | 9        |
| CG28ATYPEPD   | 50380 | E-8      | 10       | 0261-14006-1   | 15942 | E-3     | 9        |
| H-32-SW       | 45014 | E-10     | 5        | 0261-1-4006-1  | 15942 | E-4     | 9        |
| H-32-SW       | 45014 | E-11     | 6        | 0261-1-4014-1  | 15942 | E-2     | 10       |
| L-45-S        | 75535 | E-7      | 1        | 0261-14014-2   | 15942 | E-2     | 1        |
| LS3-P         | 96652 | E-9      | 5        | 0261-140143    | 15942 | E-3     | 10       |
| 0261-1-2008-1 | 15942 | E-1      | 2        | 0261-1-40144   | 15942 | E-3     | 1        |
| 0261-1-2009-1 | 15942 | E-1      | 7        | 0261-14014-5   | 15942 | E-4     | 10       |
| 0261-1-2010-1 | 15942 | E-1      | 3        | 0261-14014-6   | 15942 | E-4     | 1        |
| 0261-1-2011-1 | 15942 | E-1      | 4        | 0261-1-40147   | 15942 | E-5     | 1        |
| 0261-1-2012-1 | 15942 | E-1      | 5        | 0261-1-4015-1  | 15942 | E-9     | 19       |
| 0261-1-2013-1 | 15942 | E-1      | 6        | 0261-1-4015-10 | 15942 | E-9     | 30       |
| 0261-1-2027-1 | 15942 | E-6      | 12       | 0261-1-4015-2  | 15942 | E-9     | 20       |
| 0261-1-2054-1 | 15942 | E-6      | 45       | 0261-14015-3   | 15942 | E-9     | 21       |
| 0261-1-2072-1 | 15942 | E-1      | 1        | 0261-14015-4   | 15942 | E-9     | 22       |
| 0261-1-2083-1 | 15942 | E-7      | 2        | 0261-1-4015-5  | 15942 | E-9     | 23       |
| 0261-1-2112-1 | 15942 | E-9      | 14       | 0261-1-4015-6  | 15942 | E-9     | 26       |
| 0261-1-2157-1 | 15942 | E-1      | 8        | 0261-14015-7   | 15942 | E-9     | 27       |
| 0261-1-2166-1 | 15942 | E-6      | 58       | 0261-1-4015-8  | 15942 | E-9     | 28       |
| 0261-1-2174-1 | 15942 | E-6      | 2        | 0261-1-4015-9  | 15942 | E-9     | 29       |
| 0261-1-2185-1 | 15942 | E-9      | 8        | 0261-1-4019-1  | 15942 | E-5     | 9        |
| 0261-1-2186-1 | 15942 | E-9      | 11       | 0261-1-4019-2  | 15942 | E-5     | 8        |
| 0261-1-2187-1 | 15942 | E-9      | 10       | 0261-14023-1   | 15942 | E-6     | 13       |
| 0261-1-3021-1 | 15942 | E-6      | 5        | 0261-1-4033-1  | 15942 | E-10    | 1        |
| 0261-1-3022-1 | 15942 | E-6      | 15       | 0261-1-4034-1  | 15942 | E-9     | 24       |
| 0261-1-3025-1 | 15942 | E-6      | 11       | 0261-1-4041-1  | 15942 | E-6     | 14       |
| 0261-1-3026-1 | 15942 | E-6      | 3        | 0261-14041-2   | 15942 | E-6     | 20       |
| 0261-1-3032-1 | 15942 | E-10     | 6        | 0261-1-4044-1  | 15942 | E-6     | 18       |
| 0261-1-3042-1 | 15942 | E-6      | 7        | 0261-14045-1   | 15942 | E-6     | 17       |
| 0261-1-3046-1 | 15942 | E-6      | 16       | 0261-14047-1   | 15942 | E-6     | 10       |
| 0261-1-3060-1 | 15942 | E-6      | 57       | 0261-14047-2   | 15942 | E-6     | 19       |
| 0261-1-3061-1 | 15942 | E-6      | 46       | 0261-14053-1   | 15942 | E-6     | 23       |
| 0261-1-3084-1 | 15942 | E-7      | 3        | 0261-1-4055-1  | 15492 | E-6     | 1        |
| 0261-1-3089-1 | 15942 | E-1      | 24       | 0261-14056-1   | 15942 | E-6     | 42       |
| 0261-1-3089-2 | 15942 | E-1      | 25       | 0261-14058-1   | 15942 | E-6     | 56       |
| 0261-1-3094-1 | 15942 | E-1      | 16       | 0261-14058-2   | 15942 | E-6     | 59       |
| 0261-1-3094-1 | 15942 | E-7      | 13       | 0261-14059-1   | 15942 | E-6     | 52       |
| 0261-1-3102-1 | 15942 | E-11     | 5        | 0261-14062-1   | 15942 | E-6     | 4        |
| 0261-1-3102-2 | 15942 | E-11     | 7        | 0261-14062-2   | 15942 | E-6     | 6        |
| 0261-1-3125-1 | 15942 | E-7      | 10       | 0261-14063-1   | 15942 | E-6     | 9        |
| 0261-1-3159-1 | 15942 | E-1      | 17       | 0261-1-4063-2  | 15942 | E-6     | 21       |
| 0261-1-3164-1 | 15942 | E-9      | 4        | 0261-1-4075-1  | 15942 | E-9     | 6        |
| 0261-1-3166-1 | 15942 | E-6      | 54       | 0261-14075-2   | 15942 | E-9     | 34       |
| 0261-1-3173-1 | 15942 | E-7      | 4        | 0261-14081-1   | 15942 | E-9     | 12       |
| 0261-1-3182   | 15942 | E-11     | 8        | 0261-14088-1   | 15942 | E-1     | 23       |

## Section IV. NATIONAL STOCK NUMBER AND PART NUMBER INDEX

| PART NUMBER   | FSCM  | FIG. NO. | ITEM NO. | PART NUMBER   | FSCM  | FIG. NO. | ITEM NO. |
|---------------|-------|----------|----------|---------------|-------|----------|----------|
| 0261-14088-2  | 15942 | E-7      | 15       | 2077-7315     | 15942 | E-6      | 28       |
| 0261-1-4090-1 | 15942 | E-1      | 12       | 2077-7327     | 15942 | E-9      | 13       |
| 0261-1-4101-1 | 15942 | E-7      | 7        | 2077-7347     | 15942 | E-2      | 7        |
| 0261-1-4124-1 | 15942 | E-7      | 9        | 2077-7347     | 15942 | E-3      | 7        |
| 0261-1-4127-1 | 15942 | E-11     | 1        | 2077-7347     | 15942 | E4       | 7        |
| 0261-1-4128-1 | 15942 | E-9      | 25       | 2077-7347     | 15942 | E-5      | 4        |
| 9261-1-4130-1 | 15942 | E-12     | 9        | 2077-7907     | 15942 | E-6      | 38       |
| 0261-1-4133-1 | 15942 | E-9      | 18       | 2077-7907     | 15942 | E-12     | 8        |
| 0261-1-4134-1 | 15942 | E-6      | 22       | 2077-7925     | 15942 | E-6      | 43       |
| 0261-1-4134-2 | 15942 | E-6      | 8        | 2077-8813     | 15942 | E-6      | 41       |
| 0261-14171-1  | 15942 | E-6      | 51       | 2077-9245     | 15942 | E-1      | 22       |
| 1/2 DIA-MED   | 06550 | E-8      | 24       | 2077-9255     | 15942 | E-7      | 12       |
| 1/2NC         | 06550 | E-8      | 2        | 2077-9257     | 15942 | E-7      | 14       |
| 1/2NCX-2      | 06550 | E-8      | 4        | 2078-2818     | 15942 | E-10     | 4        |
| 1/2NCXI-1/4   | 06550 | E-8      | 1        | 2078-3319     | 15942 | E-9      | 9        |
| 1/4DIA        | 06550 | E-8      | 15       | 2100-0123     | 15942 | E-6      | 34       |
| 10-24MS       | 06550 | E-8      | 14       | 2100-0123     | 15942 | E-9      | 17       |
| 10/24NUT      | 06550 | E-8      | 16       | 2100-0123     | 15942 | E-10     | 10       |
| 1072          | 06550 | E-8      | 18       | 2100-0123     | 15942 | E-11     | 10       |
| 1173          | 75535 | E-6      | 44       | 2100-0127     | 15942 | E-2      | 5        |
| 120-B-IIT     | 06550 | E-8      | 6        | 2100-0127     | 15942 | E-3      | 5        |
| 120-50LINK    | 06550 | E-8      | 3        | 2100-0127     | 15942 | E-4      | 5        |
| 1929          | 06550 | E-8      | 26       | 2100-0127     | 15942 | E-5      | 2        |
| 2-3/16 RCJ    | 21335 | E-8      | 17       | 2100-0127     | 15942 | E-6      | 27       |
| 2000B20       | 06550 | E-12     | 5        | 2100-0127     | 15942 | E-9      | 3        |
| 2027-1479     | 15942 | E-11     | 9        | 2100-0131     | 15942 | E-6      | 31       |
| 2027-1482     | 15942 | E-11     | 3        | 21000131      | 15942 | E-12     | 6        |
| 2027-1484     | 15942 | E-11     | 2        | 2100-0137     | 15942 | E-1      | 13       |
| 2044          | 06550 | E-8      | 25       | 2100-0137     | 15942 | E-7      | 5        |
| 2047          | 06550 | E-8      | 5        | 2100-0137     | 15942 | E-12     | 12       |
| 2076-4295     | 15942 | E-1      | 11       | 2100-0149     | 15942 | E-1      | 20       |
| 2076-4370     | 15942 | E-2      | 4        | 2100-0149     | 15942 | E-7      | 11       |
| 20764370      | 15942 | E-3      | 4        | 2100-0223     | 15942 | E-10     | 2        |
| 20764370      | 15942 | E-4      | 4        | 2100-0227     | 15942 | E-9      | 7        |
| 2076-4370     | 15942 | E-9      | 31       | 2100-0878-001 | 15942 | E-1      | 9        |
| 2077-6806     | 15942 | E-11     | 12       | 2100-0878-001 | 15942 | E-2      | 2        |
| 2077-6808     | 15942 | E-6      | 32       | 2100-0878-001 | 15942 | E-3      | 2        |
| 2077-6808     | 15942 | E-9      | 15       | 2100-0878-001 | 15942 | E-4      | 2        |
| 2077-6812     | 15942 | E-6      | 37       | 2100-0878-001 | 15942 | E-5      | 5        |
| 2077-6814     | 15942 | E-10     | 7        | 2100-0878-001 | 15942 | E-9      | 33       |
| 2077-6829     | 15942 | E-6      | 47       | 2300-0053     | 15942 | E-10     | 9        |
| 2077-6834     | 15942 | E-6      | 49       | 2300-0053     | 15942 | E-11     | 11       |
| 2077-7305     | 15942 | E-9      | 1        | 2300-0055     | 15942 | E-11     | 4        |
| 2077-7309     | 15942 | E-6      | 35       | 2300-0153     | 15942 | E-6      | 33       |
| 2077-7311     | 15942 | E-6      | 24       | 2300-0153     | 15942 | E-9      | 16       |

## Section IV. NATIONAL STOCK NUMBER AND PART NUMBER INDEX

| PART NUMBER   | FSCM  | FIG. NO. | ITEM NO. | PART NUMBER  | FSCM  | FIG NO. | ITEM NO. |
|---------------|-------|----------|----------|--------------|-------|---------|----------|
| 2300-0155     | 15942 | E-2      | 6        | 2349-0090    | 15942 | E-6     | 25       |
| 2300-0155     | 15942 | E-3      | 6        | 2349-0091    | 15942 | E-6     | 29       |
| 2300-0155     | 15942 | E-4      | 6        | 2349-0091    | 15942 | E-6     | 39       |
| 2300-0155     | 15942 | E-5      | 3        | 2350-0044    | 15942 | E-12    | 2        |
| 2300-0155     | 15942 | E-6      | 26       | 2350-0048    | 15942 | E-8     | 23       |
| 2300-0155     | 15942 | E-9      | 2        | 2350-1103    | 15942 | E-6     | 48       |
| 2300-0157     | 15942 | E-6      | 30       | 2350-1253    | 15942 | E-11    | 1        |
| 2300-0157     | 15942 | E-6      | 40       | 2350-1257    | 15942 | E-8     | 22       |
| 2300-0157     | 15942 | E-12     | 7        | 2350-3010    | 15942 | E-12    | 3        |
| 2300-0163     | 15942 | E-1      | 14       | 2350-3014    | 15942 | E-8     | 21       |
| 2300-0163     | 15942 | E-7      | 6        | 2450-0449    | 15942 | E-7     | 8        |
| 2300-0163     | 15942 | E-12     | 11       | 2450-0532    | 15942 | E-2     | 8        |
| 2300-0317     | 15942 | E-1      | 10       | 2450-0532    | 15942 | E-3     | 8        |
| 2300-0317     | 15942 | E-2      | 3        | 2450-0532    | 15942 | E-4     | 8        |
| 2300-0317     | 15942 | E-3      | 3        | 2450-0532    | 15942 | E-5     | 10       |
| 2300-0317     | 15942 | E-4      | 3        | 2630-0032    | 15942 | E-8     | 20       |
| 2300-0317     | 15942 | E-5      | 6        | 2630-0340    | 15942 | E-12    | 4        |
| 2300-0317     | 15942 | E-9      | 32       | 40612        | 12437 | E-6     | 50       |
| 2300-0911     | 15942 | E-10     | 3        | 5/16NC       | 06550 | E-8     | 13       |
| 2300-4370     | 15942 | E-5      | 7        | 5/16NCX1-1/4 | 06550 | E-8     | 12       |
| 2310-0138     | 15942 | E-6      | 53       | 5/8DIA-MED   | 06550 | E-8     | 8        |
| 2310-0612     | 15942 | E-1      | 21       | 5/8NC-HEAVY  | 06550 | E-8     | 9        |
| 2310-0612     | 15942 | E-6      | 55       | 5/8NCX2-1/4  | 06550 | E-8     | 7        |
| 2310-0618     | 15942 | E-1      | 15       | 87000        | 05805 | E-8     | 11       |
| 2310-0618     | 15942 | E-12     | 10       | 8900-0249    | 15942 | E-1     | 18       |
| 2349-0029-005 | 15942 | E-6      | 36       | 8900-0291    | 15942 | E-1     | 19       |
| 2349-0029-005 | 15942 | E-10     | 8        |              |       |         |          |

## APPENDIX F

## EXPENDABLE SUPPLIES AND MATERIALS LIST

## Section I. INTRODUCTION

**F-1. SCOPE.** This appendix lists expendable supplies and materials you will need to operate and maintain the TS-1A Antenna Tower. These items are authorized to you by CTA 50-970, Expendable Items (except Medical, Class V, Repair Parts, and Heraldic Items).

**F-2. EXPLANATION OF COLUMNS.**

*a. Column 1, Item Number.* This number is assigned to the entry in the listing and is referenced in the narrative instructions to identify the material (e.g., "Use cleaning compound, item 5, Appendix F").

*b. Column 2, Level.* This column identifies the lowest level of maintenance that requires the listed item.

O Organizational maintenance

*c. Column 3, National Stock Number (NSN).* This is the NSN assigned to the item; use it to request or requisition the item.

*d. Column 4, Description.* Indicates the Federal Item name and, if required, a description to identify the item. The last line for each item indicates the part number followed by the Federal Supply Code for Manufacturer (FSCM) in parentheses, if applicable.

*e. Column 5, Unit of Measure (U/M).* Indicates the measure used in performing the actual maintenance function. This measure is expressed by a two-character alphabetical abbreviation (e.g., ea, in, pr). If the U/M differs from the unit of issue, requisition the lowest unit that will satisfy your requirements.

## Section II. EXPENDABLE SUPPLIES AND MATERIALS LIST

| (1)<br>Item<br>Number | (2)<br>Level | (3)<br>National<br>Stock Number | (4)<br>Description                                                                                                                                                                                                | (5)<br>U/M |
|-----------------------|--------------|---------------------------------|-------------------------------------------------------------------------------------------------------------------------------------------------------------------------------------------------------------------|------------|
| 1                     | O            | 7920-00-356-4694                | Brush, bristle, 1-in.                                                                                                                                                                                             | ea         |
| 2                     | O            | 8305-00-267-3015                | Cloth, lint-free                                                                                                                                                                                                  | no         |
| 3                     | O            |                                 | Lubricants<br><br>Grease - Mobil Temp 78<br>Oil- Alvania EP132°F<br>Oil - Alvania EP2 +32°F<br>Oil - Avrex 903<br>Oil - Mobil Fluid 423<br>Oil - Mobil Oil Co HD90<br>Oil - Mobil Oil Co 600 W<br>Oil - SAE 30 WT | can        |
| 4                     | O            |                                 | Plank, fir, 2- by 6-inch                                                                                                                                                                                          | ea         |
| 5                     | O            |                                 | Plate, aluminum alloy                                                                                                                                                                                             | ea         |
| 6                     | O            | 6850-00-935-1082                | Trichloroethane                                                                                                                                                                                                   | can        |



INDEX

| <i>Subject</i>                                   | <i>Paragraph,<br/>Figure, Table<br/>Number</i> |
|--------------------------------------------------|------------------------------------------------|
| <b>A</b>                                         |                                                |
| Adapter, Tower; see Tower Adapter                |                                                |
| AN/GSA-131(V)1; see Antenna Group AN/GSA-131(V)1 |                                                |
| AN/GSA-131(V)2; see Antenna Group AN/GSA-131(V)2 |                                                |
| Antenna                                          |                                                |
| Attachment.....                                  | 2-17                                           |
| Installation.....                                | 2-17                                           |
| Removal.....                                     | 5-10                                           |
| Antenna Carriage Assembly                        |                                                |
| Assembly.....                                    | 7-8, F7-3                                      |
| Description.....                                 | 1-8                                            |
| Disassembly.....                                 | 7-2, F 7-3                                     |
| Inspection.....                                  | 5-13                                           |
| Installation.....                                | 2-16,<br>F 2-18                                |
| Lubrication.....                                 | F 5-3                                          |
| Removal.....                                     | 5-10, F 5-6                                    |
| Test.....                                        | 2-17                                           |
| Antenna Elevator                                 |                                                |
| Description.....                                 | 1-8                                            |
| Inspection.....                                  | 5-13                                           |
| Installation.....                                | 2-16, F2-18                                    |
| Removal.....                                     | F 5-6                                          |
| Tests.....                                       | 2-17                                           |
| Antenna Group AN/GSA-131 (V)1.....               | 1-7                                            |
| Antenna Group AN/GSA-131 (V)2.....               | 1-7                                            |
| Antenna Installation Platform.....               | 2-17                                           |
| Antenna Tower TS-1A                              |                                                |
| Assembly.....                                    | 2-12, F 2-7                                    |
| Characteristics.....                             | 1-9                                            |
| Cleaning.....                                    | 5-12                                           |
| Components.....                                  | T 1-1                                          |
| Controls.....                                    | 3-2, T 3-1,<br>F 3-1                           |
| Description.....                                 | 1-8, F 1-1                                     |
| Direct Support Maintenance.....                  | 7-5                                            |
| Functioning.....                                 | 6-1, 6-2                                       |
| Inspection.....                                  | 5-13                                           |
| Installation.....                                | 2-8                                            |
| Lowering.....                                    | 5-10, F 5-9                                    |
| Lubrication.....                                 | F 5-1                                          |
| Operation.....                                   | 3-3                                            |
| Organizational Maintenance.....                  | 5-9                                            |
| Preliminary Checks.....                          | 5-6, T 5-4                                     |

INDEX - Continued

| <i>Subject</i>                  | <i>Paragraph,<br/>Figure, Table<br/>Number</i> |
|---------------------------------|------------------------------------------------|
| <b>A - Continued</b>            |                                                |
| Antenna Tower TS-IA - Continued |                                                |
| Purpose .....                   | 1-7                                            |
| Raising .....                   | 2-15, F2-13                                    |
| Removal .....                   | 5-10                                           |
| Repair .....                    | 7-7                                            |
| Siting.....                     | 2-1                                            |

**B**

None

**C**

|                                                  |                      |
|--------------------------------------------------|----------------------|
| Cable, Erection; see Erection Cable              |                      |
| Calibration .....                                | 1-5                  |
| Carriage Assembly; see Antenna Carriage Assembly |                      |
| Carriage Kit .....                               | 1-8                  |
| Cleaning .....                                   | 5-12                 |
| Climate                                          |                      |
| Arctic .....                                     | 3-5                  |
| Desert .....                                     | 3-6, 5-7             |
| High Winds .....                                 | 3-8                  |
| Tropical .....                                   | 3-7, 5-7             |
| Controls .....                                   | 3-2, F 3-1,<br>T 3-1 |

**D**

|                                   |      |
|-----------------------------------|------|
| Destruction of Army Materiel..... | 1-3  |
| Direct Support Maintenance        |      |
| Maintenance .....                 | 7-5  |
| Testing .....                     | 7-10 |
| Tools and Equipment .....         | 7-2  |
| Troubleshooting .....             | 7-4  |

**E**

|                   |            |
|-------------------|------------|
| Elevator Assembly |            |
| Assembly .....    | 7-8, F 7-4 |
| Description ..... | 1-8        |

INDEX - Continued

| <i>Subject</i>                              | <i>Paragraph,<br/>Figure, Table<br/>Number</i> |
|---------------------------------------------|------------------------------------------------|
| <b>E - Continued</b>                        |                                                |
| Elevator Assembly - Continued               |                                                |
| Disassembly .....                           | 7-6, F 7-4                                     |
| Lubrication .....                           | F 5-3                                          |
| Operation .....                             | 3-3                                            |
| Removal .....                               | 2-18                                           |
| Shutdown .....                              | 3-3                                            |
| Test .....                                  | 2-17                                           |
| Elevator Hoist Assembly                     |                                                |
| Controls .....                              | T 3-1, F 3-1                                   |
| Description .....                           | 1-8                                            |
| Functioning .....                           | 6-2                                            |
| Installation .....                          | 2-16, F2-15                                    |
| Lubrication .....                           | 5-5, F 5-2,<br>T 5-2, T 5-3                    |
| Removal .....                               | 5-10, F 5-7                                    |
| Erection Cable .....                        | 1-8                                            |
| Erection Kit, Tower; see Tower Erection Kit |                                                |

**F**

None

**G**

|                                               |              |
|-----------------------------------------------|--------------|
| Gin Pole                                      |              |
| Description .....                             | 1-8          |
| Disassembly .....                             | 2-15         |
| Installation.....                             | 2-12, F 2-6  |
| Grating Assemblies                            |              |
| Attachment .....                              | 2-14, F2-12  |
| Removal .....                                 | 5-10, F 5-10 |
| Grounding Kit, Tower; see Tower Grounding Kit |              |

**H**

|                               |                     |
|-------------------------------|---------------------|
| Hoist Control .....           | 2-19, 6-2,<br>F 6-1 |
| Hoist, Tower; see Tower Hoist |                     |
| Horizontal Tracks             |                     |
| Installation.....             | 2-14, F2-11         |
| Removal .....                 | 5-10                |

**I, J, K**

None

INDEX - Continued

| <i>Subject</i>                                    | <i>Paragraph,<br/>Figure, Table<br/>Number</i> |
|---------------------------------------------------|------------------------------------------------|
| <b>L</b>                                          |                                                |
| Lubrication Instructions .....                    | 5-4                                            |
| <b>M</b>                                          |                                                |
| Maintenance                                       |                                                |
| Direct Support .....                              | 7-5                                            |
| Forms .....                                       | 1-2                                            |
| Organizational .....                              | 5-9                                            |
| Preventive .....                                  | 5-6, T 5-4                                     |
| Multi-Leg Sling Assembly .....                    | 1-8                                            |
| <b>N</b>                                          |                                                |
| None                                              |                                                |
| <b>O</b>                                          |                                                |
| Obstruction Light .....                           | 1-8                                            |
| Operator/Crew                                     |                                                |
| Controls .....                                    | 3-2, F 3-1,<br>T 3-1                           |
| Organizational Maintenance                        |                                                |
| Preventive Maintenance Checks and Services.....   | 5-6, T 5-4                                     |
| Tools and Equipment .....                         | 5-1, T 5-1                                     |
| Troubleshooting .....                             | 5-8, T 5-5                                     |
| <b>P</b>                                          |                                                |
| Pier                                              |                                                |
| Construction .....                                | F 2-2                                          |
| Layout .....                                      | F 2-1                                          |
| Loads .....                                       | F 2-3                                          |
| Pivots, Tower; see Tower Pivots                   |                                                |
| Preventive Maintenance Checks and Services        |                                                |
| Organizational .....                              | 5-6, T 5-4                                     |
| <b>Q</b>                                          |                                                |
| None                                              |                                                |
| <b>R</b>                                          |                                                |
| Repainting .....                                  | 5-2                                            |
| Reporting                                         |                                                |
| Equipment Improvement Recommendation (EIR's)..... | 1-6                                            |

INDEX - Continued

| <i>Subject</i>                             | <i>Paragraph,<br/>Figure, Table<br/>Number</i> |
|--------------------------------------------|------------------------------------------------|
| <b>R - Continued</b>                       |                                                |
| Rope Guide Assembly                        |                                                |
| Lubrication.....                           | F 5-5                                          |
| Removal.....                               | 5-10, F 5-7                                    |
| <b>S</b>                                   |                                                |
| Safety Precautions.....                    | 2-15, 2-16,<br>2-17, 3-3,<br>5-10              |
| Scaffold Winch Assembly                    |                                                |
| Assembly.....                              | 7-8, F 7-1                                     |
| Disassembly.....                           | 7-6, F 7-1                                     |
| Installation.....                          | 2-14, F2-11                                    |
| Removal.....                               | 5-10                                           |
| Snatch Block.....                          | 1-8                                            |
| Steel Fasteners                            |                                                |
| Galvanized.....                            | T 2-3                                          |
| Stainless.....                             | T 2-4                                          |
| Storage                                    |                                                |
| Administrative.....                        | 1-4                                            |
| <b>T</b>                                   |                                                |
| Tackle Block Assembly                      |                                                |
| Assembly.....                              | 2-16, F2-16,<br>F 2-17                         |
| Disassembly.....                           | 2-16, F 2-16,<br>F 2-17                        |
| Tests                                      |                                                |
| Carriage.....                              | 2-17                                           |
| Elevator.....                              | 2-17                                           |
| Tools and Equipment                        |                                                |
| Direct Support.....                        | 7-2                                            |
| Installation.....                          | 2-8, T 2-2                                     |
| Organizational.....                        | 5-1, T 5-1                                     |
| Tower Adapter                              |                                                |
| Assembly.....                              | 2-14                                           |
| Description.....                           | 1-8                                            |
| Grating Assemblies; see Grating Assemblies |                                                |
| Horizontal Tracks; see Horizontal Tracks   |                                                |
| Inspection.....                            | 5-13                                           |
| Installation.....                          | 2-14, F2-10,<br>F 2-11,<br>F 2-12              |
| Lubrication.....                           | F 5-4                                          |
| Removal.....                               | 5-10                                           |

INDEX - Continued

| <i>Subject</i>                         | <i>Paragraph,<br/>Figure, Table<br/>Number</i> |
|----------------------------------------|------------------------------------------------|
| <b>T - Continued</b>                   |                                                |
| Tower Erection Kit                     |                                                |
| Description .....                      | 1-8, F 1-2                                     |
| Inspection.....                        | 5-13                                           |
| Tower Grounding Kit                    |                                                |
| Installation.....                      | 2-15, F2-14                                    |
| Removal .....                          | 5-10, F5-13                                    |
| Tower Hoist                            |                                                |
| Assembly .....                         | 7-8, F 7-2                                     |
| Description .....                      | 1-8                                            |
| Disassembly .....                      | 7-6, F 7-2                                     |
| Installation.....                      | 2-12, F 2-5                                    |
| Lubrication .....                      | 5-5, F 5-2,<br>T 5-2, T 5-3                    |
| Removal .....                          | 5-10                                           |
| Tower Pivots                           |                                                |
| Removal .....                          | 5-10, F5-13                                    |
| Tower Section Kit .....                | 1-8                                            |
| Tower Section No. 1                    |                                                |
| Assembly .....                         | 2-12                                           |
| Disassembly .....                      | 5-11, F5-12                                    |
| Installation .....                     | F 2-4                                          |
| Raising .....                          | 2-12                                           |
| Removal .....                          | 5-10, F5-13                                    |
| Tower Section No. 2                    |                                                |
| Assembly .....                         | 2-12                                           |
| Disassembly .....                      | 5-11, F5-12                                    |
| Removal .....                          | 5-10, F5-11                                    |
| Tower Section No. 3                    |                                                |
| Assembly .....                         | 2-12                                           |
| Disassembly .....                      | 5-11, F5-12                                    |
| Removal .....                          | 5-10, F5-11                                    |
| Tower Section No. 4                    |                                                |
| Assembly .....                         | 2-12                                           |
| Disassembly .....                      | 5-11, F5-11                                    |
| Removal .....                          | 5-10, F5-11                                    |
| Tower Support                          |                                                |
| Removal .....                          | 5-10                                           |
| Tracks                                 |                                                |
| Horizontal; see Horizontal Tracks      |                                                |
| Vertical; see Vertical Elevator Tracks |                                                |

U

|                |     |
|----------------|-----|
| Unpacking..... | 2-6 |
|----------------|-----|

INDEX - Continued

*Subject* *Paragraph,  
Figure, Table  
Number*

V

Vertical Elevator Tracks

|                                      |             |
|--------------------------------------|-------------|
| Description .....                    | 1-8         |
| Disassembly .....                    | 5-11, F 5-8 |
| Installation with tower erected..... | 2-16        |
| Installation with tower lowered..... | 2-13, F 2-9 |
| Removal with tower erected.....      | 5-10, F 5-8 |
| Removal with tower lowered.....      | 5-10, F 5-8 |

W, X, Y, Z

None

Index 7/(Index 8 Blank)

By Order of the Secretary of the Army:

Official:

J. C. PENNINGTON  
*Major General, United States Army*  
*The Adjutant General*

E. C. MEYER  
*General, United States Army*  
*Chief of Staff*

☆ U. S. GOVERNMENT PRINTING OFFICE: 1890 0 - 341-647 (577)



RECOMMENDED CHANGES TO EQUIPMENT TECHNICAL PUBLICATIONS

|                                                                                                                                                                                                                                                     |            |                                            |           |
|-----------------------------------------------------------------------------------------------------------------------------------------------------------------------------------------------------------------------------------------------------|------------|--------------------------------------------|-----------|
|  <p style="font-style: italic; margin: 0;">THEN...JOT DOWN THE<br/>DOPE ABOUT IT ON THIS FORM.<br/>CAREFULLY TEAR IT OUT, FOLD IT<br/>AND DROP IT IN THE MAIL.</p> |            | SOMETHING WRONG WITH PUBLICATION           |           |
|                                                                                                                                                                                                                                                     |            | FROM: (PRINT YOUR UNIT'S COMPLETE ADDRESS) |           |
| PUBLICATION NUMBER                                                                                                                                                                                                                                  |            | DATE SENT                                  |           |
| PUBLICATION DATE                                                                                                                                                                                                                                    |            | PUBLICATION TITLE                          |           |
| IN THIS SPACE, TELL WHAT IS WRONG AND WHAT SHOULD BE DONE ABOUT IT.                                                                                                                                                                                 |            |                                            |           |
| BE EXACT PIN-POINT WHERE IT IS                                                                                                                                                                                                                      |            |                                            |           |
| PAGE NO.                                                                                                                                                                                                                                            | PARA-GRAPH | FIGURE NO.                                 | TABLE NO. |
|                                                                                                                                                                                                                                                     |            |                                            |           |
| PRINTED NAME, GRADE OR TITLE AND TELEPHONE NUMBER                                                                                                                                                                                                   |            | SIGN HERE                                  |           |

**PIN: 014880-000**